

PLIDCO® SHEAR+PLUG®

Plugs off high pressure, high temp, high flow rate lines without interrupting service.

The PLIDCO® Shear+Plug, offers a safe and reliable way to isolate a system for repairs or valve insertion. Until now, such projects required shutdown of the plant or an entire system, unless an operative valve could be used. There has been no safe, positive plug-off technique, because existing seals could not withstand high-pressure and high temperature. The PLIDCO® Shear+Plug solves the problem by providing a positive metal-to-metal seal.

The Shear+Plug is available in pipe sizes .75" through 18" and are designed using ASME Section VIII, Division 1. 2" and smaller units are designed to meet or exceed Class 900 pressure/temperature ratings. 2.5" and larger units are designed to meet or exceed Class 600 pressure/temperature ratings. Systems for handling higher pressures, higher temperatures and larger sizes can be specially designed and manufactured and will be quoted on request.

A double-acting hydraulic cylinder accomplishes the shear through and positions the blind plate. No shell cutter is used to enter the pipe. The coupon is pushed into a receptacle housing for easy, complete retrieval.

REINFORCING RINGS

Fig. 1

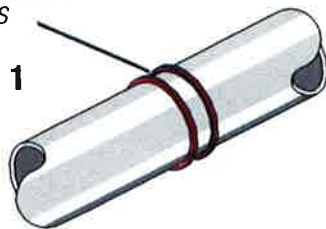

PIPE HOLDING ASSEMBLY

Fig. 2

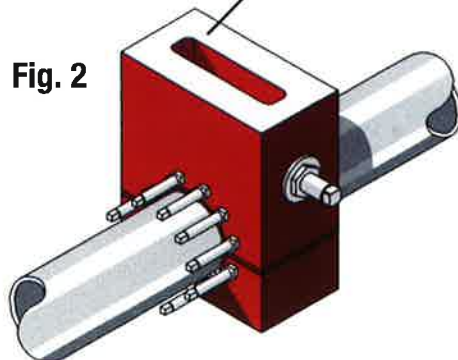

SHEAR BLADE

Fig. 3

THRUST BOLTS

BLIND PLATE RECEPTACLE HOUSING

PIPE HOLDING ASSEMBLY

COUPON RECEPTACLE HOUSING

TEST VALVE

Step 1 – Pipe is ultrasonically tested.

Step 2 – Pipe reinforcing rings are positioned on the pipe, straddling the area to be plugged, and welded in place (Fig.1).

Step 3 – The pipe holding assembly is placed in position on the pipe, and secured by welding (Fig.2) on any pipe axis.

Step 4 – Pipe notching equipment is positioned on the pipe holding assembly. Notching can be safely accomplished because axial loads on pipe are transferred through the pipe holding assembly.

Step 5 – Assembly of the PLIDCO® Shear+Plug is completed by positioning the blind plate housing and coupon receptacle housing on the pipe holding assembly (Fig. 3). Nuts on the through-bolts are securely tightened and the complete assembly is pressure tested.

Step 6 – The hydraulic cylinder is actuated, thrusting the shear blade through the pipe and pushing the coupon into the coupon receptacle housing, allowing retrieval of the entire coupon (Fig. 4).

Step 7 – The blind plate is indexed into seal position. Thrust bolts on the downstream side are tightened, which push the blind plate against the housing wall forming a metal-to-metal seal. (Sealant is injected only if needed.) The test valve is opened to release downstream pressure and to make sure the plug-off is complete.

Step 8 – While scheduled work is in progress, the coupon receptacle housing is removed—permitting retrieval of the coupon and shear blade. The first completion cap is welded to the pipe holding assembly, between the coupon receptacle housing and the pipe holding assembly.

Step 9 – Upon completion of scheduled work, the pipeline can be put back on stream. Thrust bolts are loosened; the blind plate is retracted into its receptacle housing.

Step 10 – After the blind plate is retracted, the retraction cock valve is closed. The Shear+Plug is then disassembled and the second completion cap is welded to the pipe holding assembly. (Fig. 5).

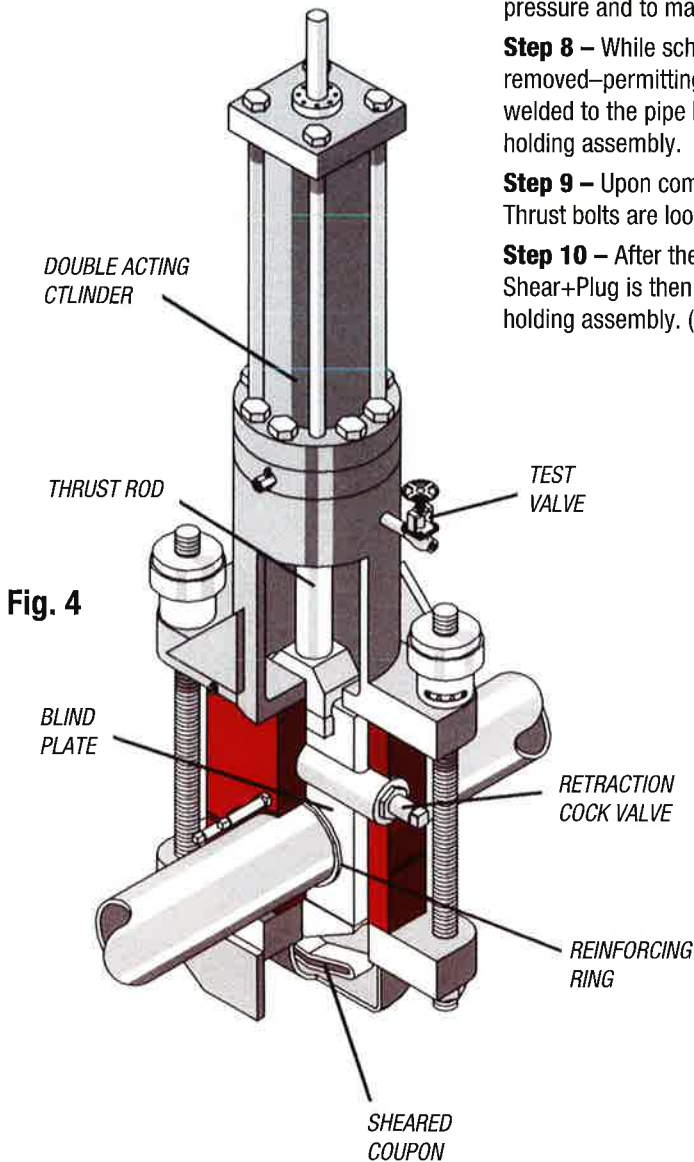

Fig. 4

COMPLETED INSTALLATION

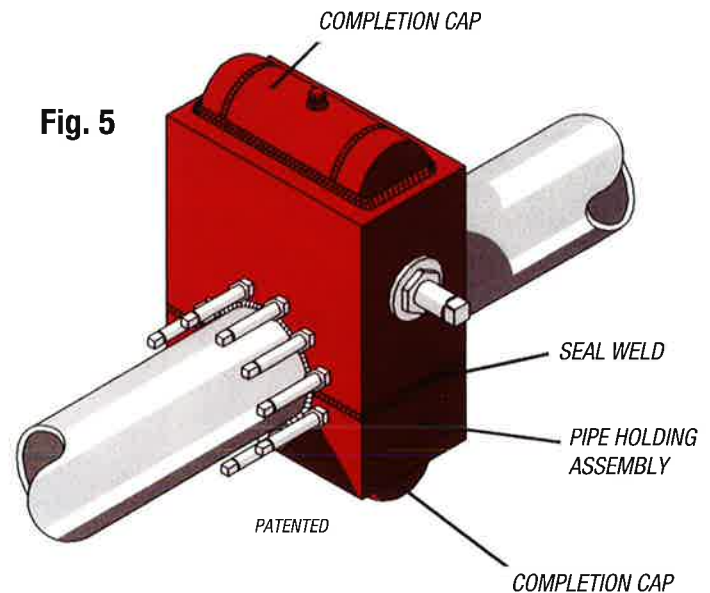

Fig. 5