

# Operating instructions

DRC-10 hand-held transmitter (D2 - with frequency hopping for 900 MHz band)

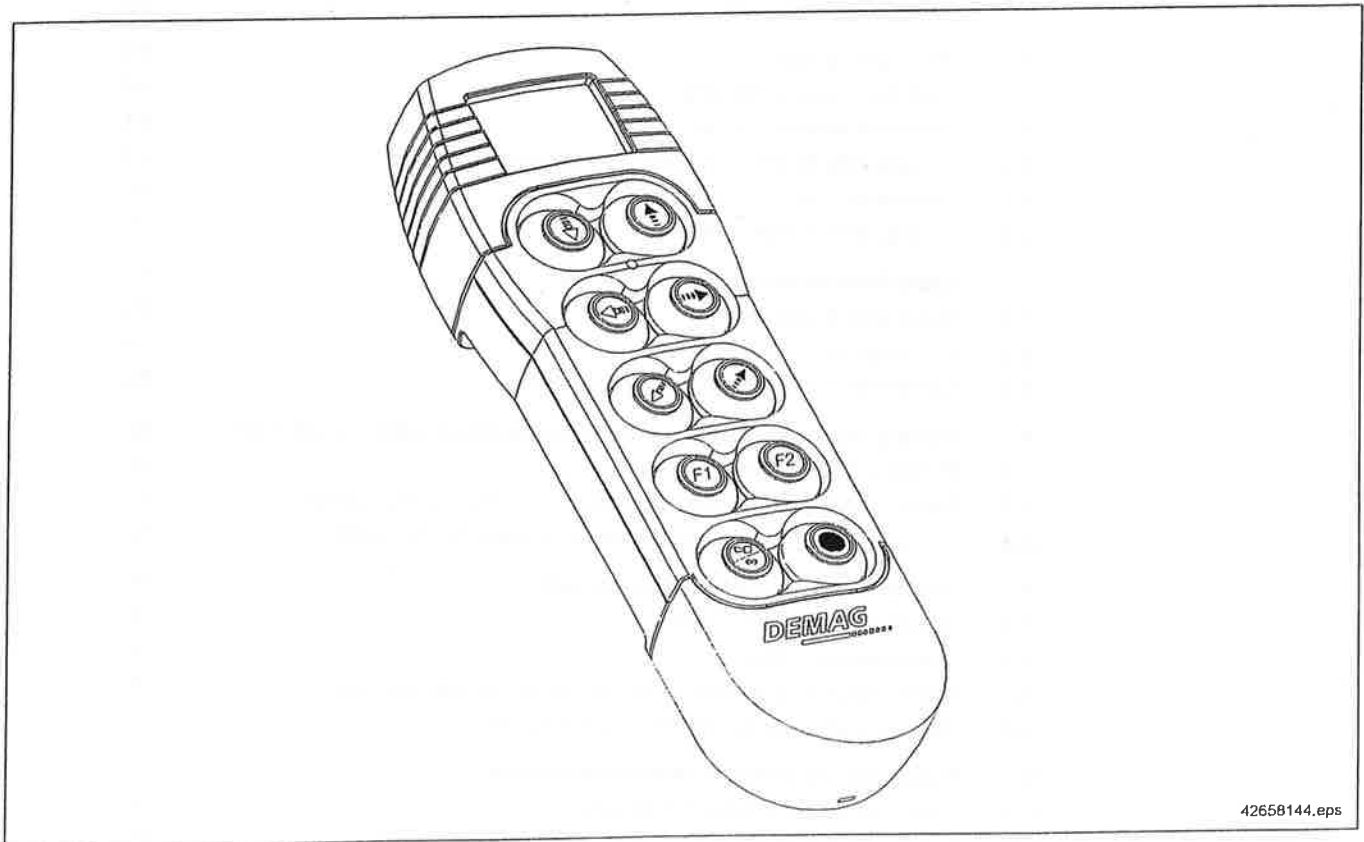

42658144.eps

# Contents

	Page
<b>1 Foreword</b>	<b>4</b>
1.1 Copyright	4
1.2 Customer service	4
1.3 Liability for Defects	5
1.4 Limitations of liability	5
1.5 Definitions	6
<b>2 Safety instructions</b>	<b>7</b>
2.1 Symbols	7
2.2 Appropriate use	7
2.3 Inappropriate use	9
2.4 Basic information on safety	9
2.5 Safety instructions for assembly and disassembly	10
2.6 Safety instructions when first putting into service after completing installation	11
2.7 Safety instructions for operation	11
<b>3 General description</b>	<b>12</b>
3.1 Transmitter/receiver interface	12
3.2 Transmission method	12
<b>4 Selection of unit</b>	<b>14</b>
4.1 DRC-10 scope of delivery	14
4.2 Available radio receivers	14
4.3 Accessories for DRC-10 hand-held transmitters	14
4.4 Accessories for crane identification	14
4.5 Casing seal/broken seal	14
<b>5 Identification and display functions</b>	<b>15</b>
5.1 Hand-held transmitter	15
5.2 LCD display	16
5.3 Identification labels for the crane installation	20
<b>6 Putting the radio control system into operation after installation</b>	<b>22</b>
6.1 Putting into operation	22
6.2 Putting a radio remote control system with DRC-10 into operation	22
6.3 Configuration of a radio remote control system for DRC-DR	26
<b>7 Operation of the radio control system</b>	<b>27</b>
7.1 Checks before starting work	27
7.2 Crane operation/Run	28
7.3 Taking the unit out of service at the end of the shift (standby)	29
7.4 Operating statuses of the radio control system	29
<b>8 Power supply of the hand-held transmitter</b>	<b>31</b>
8.1 Display of available battery capacity	31
8.2 Charging the batteries	31
8.3 Replacing the batteries	32

	Page
<b>9 Information menu in connection with DRC-DR</b>	<b>33</b>
9.1 Activating the Information menu	33
9.2 Selecting the information source	33
9.3 Activating the display travelling hoist selection	33
9.4 Starting screen	33
9.5 Navigating in the information menu	33
9.6 Data of the information menu	34
<b>10 Technical data</b>	<b>35</b>
10.1 Dimensions	35
10.2 International postal registration	36
<b>11 Eliminating faults</b>	<b>37</b>
<b>EC conformity declaration</b>	<b>40</b>
<b>Programming parameters of the DRC-10 hand-held transmitter (For authorized personnel only)</b>	<b>41</b>
<b>1 Menu for programming the hand-held transmitter</b>	<b>42</b>
1.1 Activating the menu	42
1.2 Displaying the current parameters	42
1.3 Displaying the serial number of the hand-held transmitter, Parameter code 001	42
1.4 Displaying the software version of the hand-held transmitter, Parameter code 002	43
1.5 Displaying the hardware version of the hand-held transmitter, Parameter code 003	43
1.6 Displaying and entering a fixed frequency channel, Parameter code 004	43
1.7 Displaying and entering the cut-out time in STOP mode, Parameter code 005	44
1.8 Displaying and entering the cut-out time in Run mode, Parameter code 006	45
1.9 Displaying and entering the max. quick charging time, Parameter code 007	46
1.10 Frequency hopping	46

Accompanying documents:

DRC-MP operating instructions	214 994 44	720 IS 975
DRC-DR operating instructions	214 953 44	720 IS 975 3

# 1 Foreword

You have purchased a Demag product/system.

These operating instructions are designed to provide the owner with appropriate instructions for safe and correct operation and to facilitate maintenance.

Every individual given the task of transporting, installing, commissioning, operating, maintaining and repairing our products and systems must have read and understood

- the operating instructions
- the safety regulations and
- the safety instructions in the individual chapters and sections.

The operating instructions must be available to the operating personnel at all times in order to prevent operating errors and to ensure smooth and trouble-free operation of our products/systems.

## 1.1 Copyright

These operating instructions must be treated confidentially. They should only be used by authorized personnel. They may only be entrusted or made available to third parties with the prior written consent of Demag.

All documents are protected within the sense of copyright law.

No part of this documentation may be reproduced, utilized or transmitted without specific prior consent. Infringements are an offence resulting in obligatory compensatory damages.

All industrial rights reserved.

## 1.2 Customer service

Our after-sales service will provide you with all technical information on Demag products and their systematic application.

Should you have any questions regarding our products, please refer to one of our after-sales service stations, the relevant representative or the manufacturer.

Kindly quote the serial or order number (see test and inspection booklet, load capacity plate on the crane) in any correspondence or for spare part orders.

Specifying this data ensures that you receive the correct information or the required spare parts.

### 1.3 Liability for Defects

These operating instructions must be read carefully before installing and putting the system into operation.

We assume no liability for any damage and malfunctions resulting from failure to comply with the operating instructions.

Any liability claims for defects must be made by quoting the order number immediately on detecting the defect.

**Any liability claims for defects are void in the event of:**

- inappropriate use,
- faulty devices or equipment connected or attached to the system which are not part of our scope of supplies and services,
- use of non-genuine spare parts and accessories,
- refurbishment or modification of the product unless approved in writing by Demag.

**Wearing parts are not subject to liability for defects.**

### 1.4 Limitations of liability

All technical information, data and instructions for operation contained in these operating instructions were up-to-date on going to print and are compiled on the basis of our experience and to the best of our knowledge.

We reserve the right to incorporate technical modifications within the scope of further development of the system which is the subject of these operating instructions.

Therefore, no claims can be derived from the information, illustrations and descriptions contained in these operating instructions.

The descriptions and illustrations contained in this documentation do not necessarily correspond to the scope of delivery or any subsequent spare part delivery, either; the drawings and illustrations are not to scale.

Only documentation belonging to the actual order is valid.

We assume no liability for damage and malfunctions caused as a result of operating errors, non-compliance with these operating instructions or inappropriate repairs and maintenance.

We expressly point out that only genuine Demag spare parts and accessories approved by us may be used. Accordingly, this also applies to other manufacturers' parts supplied by us.

For safety reasons, the fitting and use of spare parts or accessories which have not been approved and unauthorized modification and conversion of the product are not permitted and exempt us from any liability for damages resulting therefrom.

With the exclusion of any further claims, we are liable for any defects or omissions on our part in the products or documentation supplied within the scope of the liability obligations entered into in the original contract. Any further claims, in particular any and all claims for damages, are excluded with the exception of legal claims in accordance with product liability legislation.

## 1.5 Definitions

### **Owner**

Owners (employer, company) are defined as a person who owns such a system and who uses it appropriately or allows it to be operated by suitable and instructed persons.

### **Operating personnel/operator**

Operating personnel or operators are defined as persons entrusted by the owner of the system with the operation of the system.

### **Specialist personnel**

Specialist personnel are defined as persons assigned by the owner of the system to carry out special tasks such as installation, setting-up, maintenance and fault elimination.

### **Qualified electrician**

Qualified electricians are defined as persons who, owing to their technical training, knowledge and experience of electrical installations as well as knowledge of the relevant standards, codes of practice and regulations, are able to assess the tasks given to them and to identify and eliminate potential hazards.

### **Trained person**

Trained persons are defined as persons who have been instructed and trained for the tasks assigned to them and on the possible hazards resulting from incorrect handling and who have been informed about the required protective devices, protective measures, relevant regulations, codes of practice, accident prevention regulations and operating conditions and who have proven their qualifications.

### **Experienced technician**

Experienced technicians are defined as persons, who, owing to their technical training and experience, have sufficient knowledge of these systems and are familiar with the relevant national industrial safety regulations, codes of practice, accident prevention regulations, directives and generally accepted engineering standards enabling them to judge the safe operating condition of such systems.

## 2 Safety instructions

### 2.1 Symbol description

These symbols are used to warn against potential safety hazards or causes of damage or provide useful information.



#### Hazard warning

This symbol appears in the operating instructions next to all instructions relating to safety at work wherever a potential danger to life and limb exists.

Follow these instructions at all times and be particularly vigilant and cautious.

Pass on safety instructions to all persons entrusted with working on the product including the power supply.

In addition, observe all general safety regulations at all times.



#### Warning against dangerous electrical voltage

Contact with live parts can result in immediate death. Protective covers (e.g. covers and enclosures) marked with this sign may only be opened by qualified electricians. Before opening, all relevant operating, control, feed or other voltages must be disconnected.



#### Operating hazard for the installation

This symbol in the operating instructions indicates all warnings which, if not complied with, may result in damage to the product.

### 2.2 Appropriate use

The DRC-10 hand-held transmitter is intended to be used as an operating unit and transmitter station for the DRC-DR and DRC-MP radio receivers. The scope of functions is preferably designed for wireless control of crane installations, travelling hoist units, chain and rope hoists, transfer carriages and similar applications.

The operator can position himself as required. He can control loads and movements from a safe distance. He must always select a location to ensure that all movements of the load and the crane can be monitored and any hazardous movement can be switched off within an appropriate time. Before starting a crane movement by actuating the operating element, the operator must determine which crane is being controlled. The display of the DRC-10 hand-held transmitter shows the identification/crane number of the controlled crane. The radio-controlled crane must be identified by means of the identification/crane number in a way clearly visible to the operator. If required, a signal must be actuated prior to a crane movement for acoustic control.

DRC transmitters are designed for operation in the 900 MHz ISM band, which is the preferred frequency range for region 2 - countries as defined by the ITU (International Telecommunication Unit). Technical details see chapter ... and also the available postal approvals on page ....

Transmitters and receivers of the DRC range can be operated without any registration or operating fee, see available postal approvals on page ... 36; chapter 10.2. The benefits that this provides for the user are also utilized by some other manufacturers of devices for communications and telemetry applications. The consequence of this is that the relevant approved frequency ranges may be used by many transmitters at the same time, depending on the time and location.

The transmission method used by Demag is designed for the most robust and interference-resistant radio transmission between the transmitters and receivers of the DRC range.

The state-of-the-art transmission method is provided with technical features (e.g. frequency hopping) which are intended to ensure a minimum of conflicts for radio operation together with other transmitter and receiver devices which use the same frequency range.

Despite all of the technical precautions taken by Demag, it cannot be entirely excluded that the transmission characteristics of other radio systems are impaired, in particular devices supplied by other manufacturers that use the same frequency range, or that the transmission characteristics of the system supplied by Demag are negatively affected. In such cases, interference or radio connection interruptions may occur, which disrupt the communication and function of a system supplied by Demag or other manufacturers. Such impairment or interference does not constitute a defect on the part of DRC transmitters and receivers. Demag accepts no liability for wilful or grossly negligent behavior.

The number of transmitters that operate without any interference in a given area depends on the relevant radio solution design of all systems and the selectivity of each individual system.

If this limit is exceeded continuously or for certain periods, additional technical measures may be necessary in order to ensure simultaneous and interference-free operation of the radio systems. Whether and to which extent such measures are required can only be determined by means of suitable measurements on site or when the system is put into operation. Demag is not responsible for such additional technical measures.

Radio remote control systems of the DRC range are exclusively intended for single-transmitter operation; i.e. there is always a clear assignment between a specific transmitter and the corresponding receiver.

The DRC-10 hand-held transmitter may only be operated when in perfect working order by trained personnel in accordance with the relevant safety and accident prevention regulations. This also includes compliance with operating and maintenance conditions specified in the operating instructions.

Hand-held radio transmitters that are ready for operation must not be left unattended. They must be protected against unauthorized use.

For appropriate use, the information in the operating instructions for the receiver used (DRC-DR/DRC-MP) and the machine/crane installation to be controlled must be complied with in addition to the information contained in these operating instructions (see accompanying documents, page 3).

Serious personal injury or damage to property may occur in the event of:

- unauthorized removal of covers,
- inappropriate use of the product/system,
- incorrect operation,
- insufficient maintenance,
- working on live parts.



## 2.3 Inappropriate use

Certain work and practices are prohibited when using the system as they may involve danger to life and limb and result in lasting damage to the product, e.g.:

- Manipulating electrical equipment
- Connecting the unit to power supply with voltage or frequency other than those specified on the type plate
- Non-compliance with specified mounting positions
- Non-compliance with the max. permissible operating temperature.

Other inappropriate applications may be caused by non-compliance with the information in the operating instructions for the radios receiver used (DRC-DR/DRC-MP) or for the machine to be controlled.

## 2.4 Basic information on safety

Persons under the influence of drugs, alcohol or medicines which affect reactions must not install, operate, put into service, maintain, repair or disassemble the product. Any conversions and modifications to the installation must comply with the safety requirements. Work on electrical equipment may only be carried out by specialists in accordance with electrical regulations.

In the event of malfunctions, the system must be shutdown, switched off and the relevant main switches locked immediately.

**Malfunctions must be eliminated immediately.**

National accident prevention regulations and codes of practice and general safety regulations must be observed when operating our products. Important information and instructions are marked by corresponding symbols. Follow these operating and safety instructions to avoid personal injury and damage to machinery.

The operating instructions must be kept available at the place where the system is in use at all times.

They include significant aspects and appropriate excerpts from the relevant guidelines, standards and regulations. The owner must instruct his personnel appropriately. If the safety instructions given are not observed in any way, personal injury or even death can result.

Observe general statutory and other obligatory regulations relating to accident prevention and environmental protection and basic health and safety requirements in addition to those included in these operating instructions.

Such requirements may also relate, for example, to the handling of hazardous materials or the provision/wearing of personal protection equipment.

Comply with these regulations and general accident regulations relevant for the place at which the system is used and follow the instructions therein when working with the system.

The system may still constitute a danger to life and limb if it is not installed, operated, maintained or used appropriately by personnel which have not been trained or specially instructed.

The safety instructions must, if required, be supplemented by the owner with instructions and information (e.g. factory regulations) relating to organization of work, working procedures, operating personnel, etc. Supervising and reporting obligations as well as special operating conditions must also be taken into consideration. Supervising and reporting obligations as well as special operating conditions must also be taken into consideration.

Personnel assigned to working with the system must have read the operating instructions and the safety instructions.

All activities relating to the system which are not described in the operating instructions may only be carried out by specifically trained specialist personnel.

The owner must ensure that personnel work in a safety and hazard-conscious manner in compliance with the operating instructions.

The owner must ensure that the system is only operated when in proper working order and that all relevant safety requirements and regulations are complied with.

The system must be taken out of service immediately if functional defects or irregularities are detected.

In the event of a stoppage (e.g. if defects regarding safe and reliable operation are detected, in emergency situations, in the event of operating malfunctions, for maintenance purposes, if damage is detected or after finishing work), the operator/experienced technician must carry out all prescribed safety measures or observe that they are automatically carried out.

Personal protective clothing must be worn as necessary or as required by regulations. Personnel must not wear loose clothing, jewelry including rings or long hair loose. Injury may occur, for example, by being caught or drawn into the mechanism.

All safety and hazard warnings on the product, its access routes and mains connection switches must be preserved completely and in legible condition.

Modifications, additions to and conversions of the product which might impair safety in any way must not be carried out without the approval of Demag.

Safety devices must not be rendered inoperative.

Only genuine Demag spare parts may be used. Observe prescribed deadlines or those specified in the operating instructions for routine checks/inspections.

## **2.5 Safety instructions for installation and disassembly**

- Installation and disassembly work may only be performed by experienced technicians.
- Installation and disassembly work must be co-ordinated by the person carrying out the work and the owner within the scope of their responsibility.
- The assembly zone must be made safe.
- The installation must be isolated in accordance with the relevant electrical regulations.
- Customer-specific regulations must be observed.
- Only appropriate, tested and calibrated tools may be used.

In the case of disassembly, any waste material must be disposed of by the owner in an environmentally compatible way in compliance with the valid regulations.

## 2.6 Safety instructions when first putting the unit into service after completing installation

- The working area must be made safe.
- First check that the voltage and frequency specified on the type plates match the owner's mains power supply.
- In the course of putting the product into service, it may be necessary to render safety devices or features inoperative when carrying out adjustments or function checks.
- When putting the unit into service, it may be necessary to perform work in the danger zone, therefore, it must be ensured that only appropriately trained personnel are employed for this work.

## 2.7 Safety instructions for operation

Before putting the crane into operation, the operating personnel must be satisfied that the radio control system is in safe and correct operating condition.

In addition, the safety instructions and measures contained in the operating instructions of the crane must be applied.

The clear assignment between the DRC-10 hand-held transmitter to the radio receiver (DRC-DR/DRC-MP) on the crane is the precondition for safe wireless remote control of a crane. This unique assignment is created by the exchange of the address features between transmitter and receiver when a DRC-10 hand-held transmitter is put into operation. The operating personnel recognizes which crane is controlled by means of the crane identification shown in the display of the hand-held transmitter.

Before switching on/putting into operation of the crane/machine controlled by the radio control system with the DRC-10 hand-held transmitter, it must be ensured that nobody is endangered by operation of this crane.

If the operator notices persons who may be exposed to a risk to health or personal safety by operation of the equipment, he must suspend operation immediately and may not resume operation again until the persons are outside the danger zone.

### STOP key function

Actuation of the red STOP key activates the emergency-stop function in the radio receiver on the crane. The emergency-stop function stops any potentially dangerous movement of the crane. For use of the emergency-stop function, in particular the instructions contained in the operating instructions of the crane must be complied with. When the STOP key has been actuated, the radio system is in the "STOP" operating mode. No movement commands are transmitted. The emergency-stop can be unlocked again by entering an electronic key. This may only be done after the operator has made sure that the hazardous situation which resulted in actuation of the STOP key has been eliminated.

### Warning device function

Radio-controlled cranes must be provided with a warning device (acoustic or optical). The crane operator can activate this warning device by means of the signal key in the keyboard of the hand-held transmitter to warn persons in the vicinity of the crane and/or load before starting the crane movements. The warning device must also be used if the crane operator intends to check the assignment between the hand-held transmitter and the crane receiver by means of a hand-held transmitter command.

### Range of the radio remote control system

The crane operator may only use the range of the radio control system to the extent that he can freely monitor the danger zone of the crane movements.

The range of the hand-held radio transmitter is limited and can be additionally reduced by ambient conditions. The range may also be limited by utilization of the available frequency range by other radio transmitters. The quality of the radio signal is shown in the display of the hand-held transmitter. If poor connection quality is displayed, unintended interruptions of the controlled movements may occur.

## 3 General description

### 3.1 Transmitter/receiver interface

Demag DRC radio control systems are designed for wireless control of hoist units and cranes. They are the interface for manually controlled crane installations. The applicable EC directives and standards are complied with for this application.

Demag DRC radio control systems consist of a radio transmitter/operating unit and a radio receiver with interface to the crane control system.

DRC transmitters can be operated with one specific DRC receiver; multi-receiver or multi-transmitter operation is not possible.

DRC-10 hand-held transmitters in applications in connection with DRC-DR or DRC-MP radio receivers are the subject of these operating instructions.

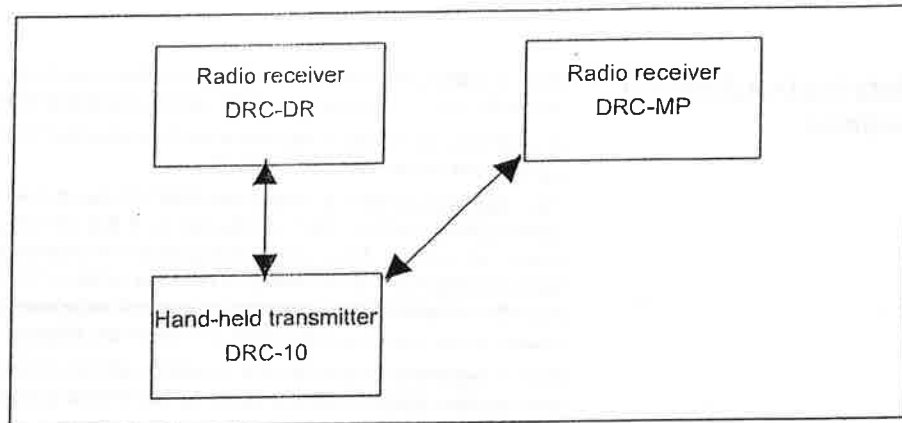

- The Demag DRC-DR radio receiver is a pluggable PCB for installation in the electrical equipment cover of the DR hoist unit. The interface of this receiver component to the crane control system and power supply by the DR electrical equipment is the CAN safety bus. The DRC-DR radio receiver is exclusively suitable for operation with a DR hoist unit.
- The Demag DRC-MP radio receiver is a complete unit with its own enclosure and power supply from the control voltage network of the crane installation. Relay contacts for the individual control commands and the emergency stop circuit form the interface of this unit to the crane control system. An additional semiconductor output with pulse width modulation is provided for infinitely variable crane drives. The DRC-MP radio receiver is suitable for a wide range of applications.

Demag radio receivers are provided for duplex operation and transmit information to the DRC-10 hand-held transmitter. This increases safety of the radio system. Status information of the crane control system and the receiver are shown in the display of the DRC-10 hand-held transmitter.

### 3.2 Transmission method

DRC transmitters are designed for operation in the 900 MHz ISM band, which is the preferred frequency range for region 2 - countries as defined by the ITU (International Telecommunication Unit). Technical details see chapter ... and also the available postal approvals on page .... Within the ISM band multiple frequencies are used alternately in a defined sequence (so-called frequency hopping). A random-check generator determines the sequence of the frequencies when radio transmission is started. In order to increase transmission reliability, the information is transmitted several times. This method in connection with frequency hopping provides for a very high immunity to interference.

A decisive advantage of the frequency hopping transmission is that existing information contents are transmitted on several physical channels. This redundant radio transmission 1) provides for an exceptionally high insensitivity of radio transmission against other transmitters or electromagnetic interference.

1) Certain information contents are transmitted on up to 5 different frequencies. Only if (theoretically) all frequencies used were occupied or disturbed by other radio systems, communication would be interrupted.

**3.2.2 Compatibility  
D1, D1 FH and D2**

DRC-D2 900 transmitter or receivers are not compatible with DRC units which operate in the 433 MHz range.

Transmitters	Compatible with receivers	
	DRC-DR D2 900 # 773 564 44	DRC-MP D2 900 # 773 595 44
DRC-DR D2 900 # 773 564 44	Yes	Yes
DRC-J D2 900 # 773 566 44	Yes	Yes

## 4 Selection of unit

	Part no.:
<b>4.1 DRC-10 scope of delivery</b>	<b>773 563 44</b>
<b>DRC-10 D2 hand-held transmitter</b>	
<b>Contents of the complete delivery</b>	
- 1 DRC-10 D2 900 hand-held transmitter	
- 1 Rechargeable battery pack 2,4 V / NiMH / 2x 2500 mAh	773 499 44
- 1 Plug-in charger (rechargeable battery) 110-230 V 50/60 Hz	773 438 44
- 1 Carrying bag with shoulder strap and belt clip	773 434 44
- 1 Operating instructions DRC-10 hand-held transmitter	214 920 44
- 1 Key symbols for transmitter DRC-10	773 465 44
<b>4.2 Available radio receivers</b>	
DRC-DR D2 900 radio receiver	773 564 44
Aerial for DRC-DR receiver for (DR 3, 5, 10, 20)	773 569 44
DRC-DR MP D2 900 radio receiver	773 595 44
<b>4.3 Accessories for DRC-10 hand-held transmitters</b>	
Silicone protective sheath	773 580 44
Improved protection against chemicals and abrasive materials	
External charger unit	773 501 44
To charge a battery pack (773 499 44)	
Connection to 230 V supply by multi-norm connector	
4 hours for full charge, automatic trickle charging	
Spare parts set for DRC-10 hand-held transmitter	773 415 33
Contents:	
1 x upper rubber cap,	
1 x lower rubber cap	
5 x bridge contacts	
<b>4.4 Accessories for crane identification</b>	
Coding labels Carrier foil, black	895 639 44
Coding labels 7 segments (yellow)	895 640 44
Travel direction foil cross travel	895 635 44
Travel direction foil long travel	895 637 44
<b>4.5 Casing seal/broken seal</b>	
	
The DRC-10 hand-held transmitter is sealed in the factory.	
The DRC-10 hand-held transmitter may only be opened for repair purposes by authorised parties.	
<b>Breaking a casing seal such as this will result in loss of all warranty rights.</b>	

## 5 Identification and display functions

### 5.1 Hand-held transmitter

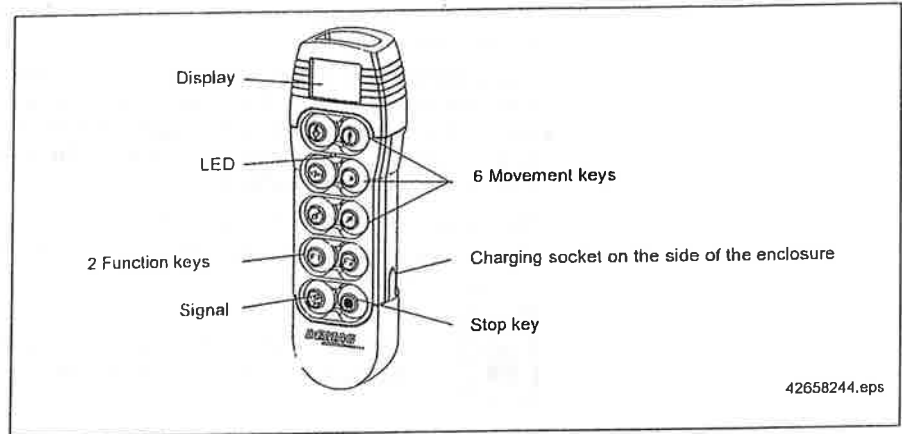

The LED in the hand-held transmitter indicates the operating status of the hand-held transmitter:

LED	Operating status
Off	The transmitter is switched off or in standby mode
Red continuously on	The transmitter is in Stop mode
Flashing green	The transmitter is in Run mode

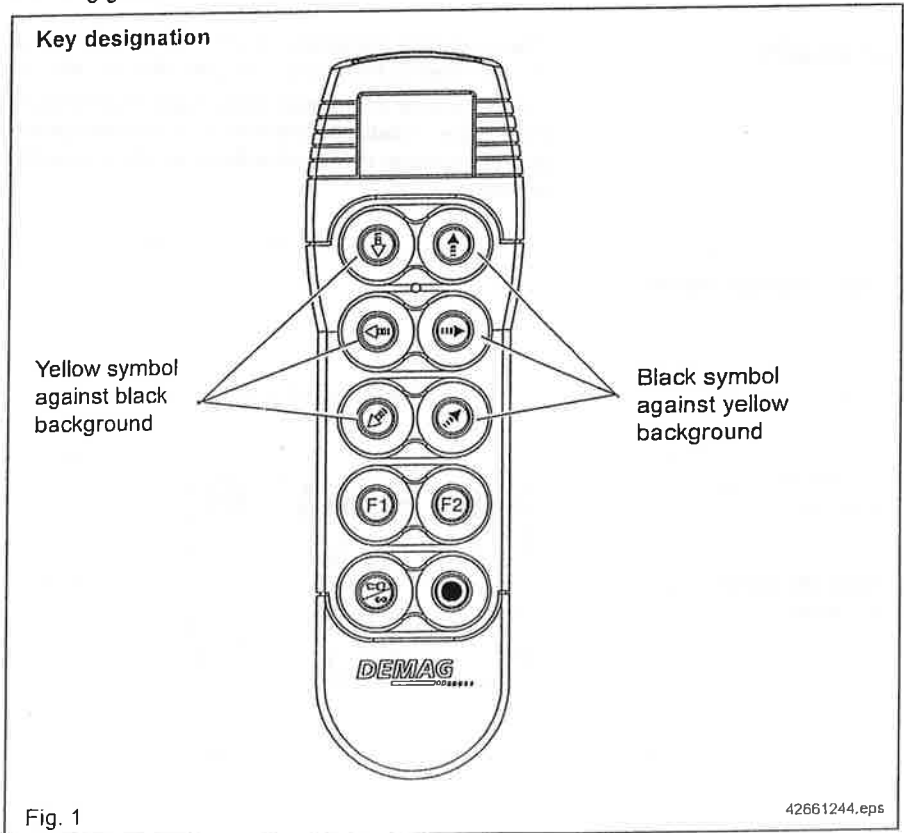

As standard, all keys on the hand-held transmitter are designated in the factory with the relevant foil symbols.

If requested by the owner, it is also possible to apply other, for example, country-specific symbols for the direction keys on the radio control system. The owner then has to remove the existing symbols and apply symbols required by him. Note that when the radio control system is used in connection with a DR rope hoist, the functions of the individual keys are pre-defined.

To replace the symbols, proceed as follows:

- The keys must be free from adhesive, dust and grease. Clean, as required, with spirit or alcohol.



**Solvents, benzene, cold sprays, etc. could damage the key material.**  
(see fig. 1 for hoist unit functions)

- Remove the symbol required for the assigned function from the symbol sheet. Attach the adhesive symbols in the relevant function key.

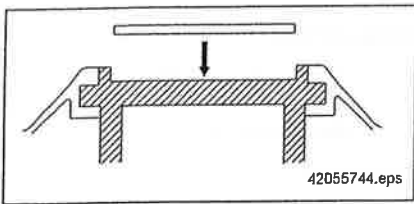

## LCD display

The hand-held transmitter is provided with a display. In the display, all data important for operation of the crane to be operated are shown.

The number of information items displayed varies depending on the type of receiver. The scope of display functions comprises the general displays which are available for both receiver types and additional information that can only be used with DRC-DR receivers.

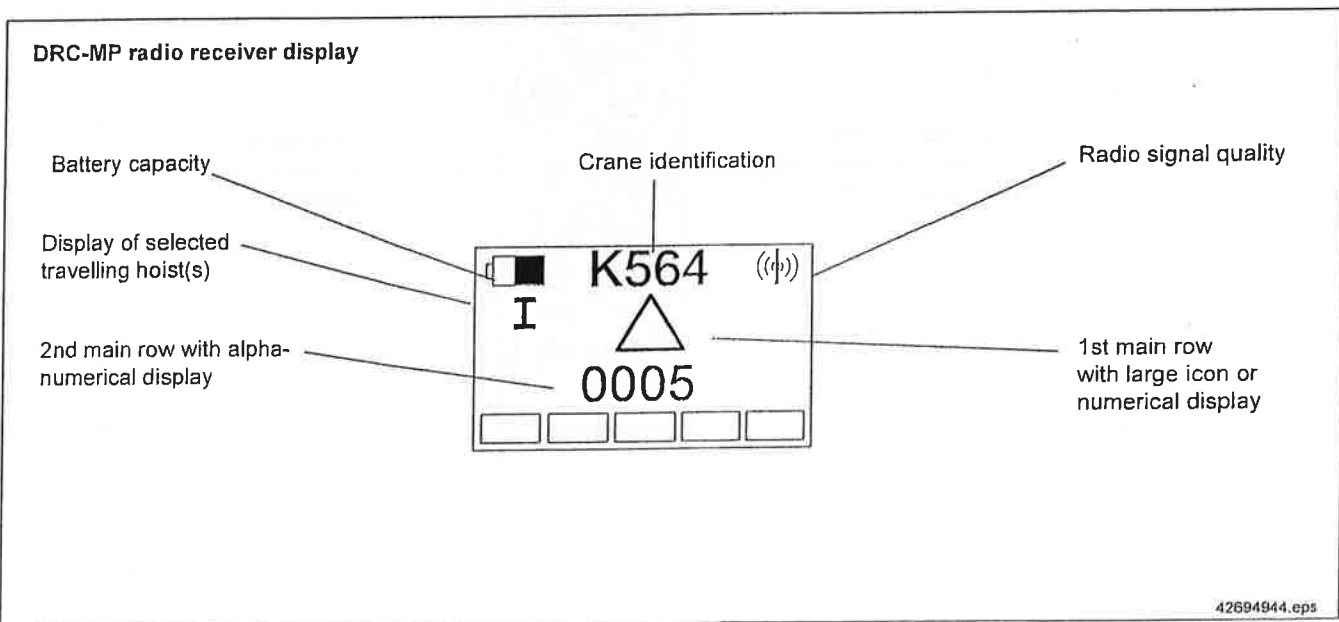

At temperatures below 0 °C, the contrast of the LDC display is reduced and the time for changing the characters increases.



## 5.2.1 General display

### Crane identification K564

The crane identification shows to which crane the hand-held transmitter has been assigned. It is saved in the radio receiver and it can only be entered via the hand-held transmitter.

### Display of selected travelling hoist(s)

The display of the selected travelling hoists is only active, if there are two travelling hoists and both can be operated with one radio control system.

Symbol	Meaning
I	Travelling hoist 1 is selected
II	Travelling hoist 2 is selected
I+II	Travelling hoists 1 and 2 are selected

**Display of radio connection quality**

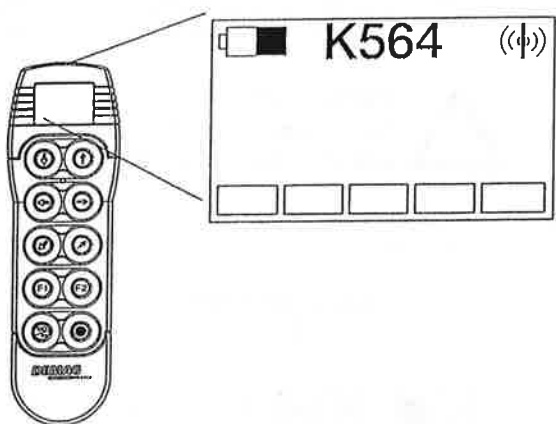

Signal strength icon

Symbol	Meaning
((Φ))	Full signal strength
(Φ)	50 % of max. range between transmitter and receiver reached
Φ	Weak signal: If the distance between the hand-held transmitter and the radio receiver is further increased, the radio connection may be interrupted.

42658944.eps



### Battery icon

The battery icon indicates the status of the rechargeable batteries. During the charging process, it is animated.

## Icons in the first main row

In the first main row, all icons important for operation are shown.



### Lock icon

The key icon indicates the Off mode. An electronic On key must be entered to switch the unit on.

**STOP**

### STOP icon

STOP indicates the STOP mode. The system switches over to Run mode with the electronic key.



### "No radio connection" icon

The "No radio connection" icon is displayed, if the hand-held transmitter failed to establish a connection to the assigned radio receiver.



### Warning icon

The warning icon is displayed in the event of a warning. The code of the warning is displayed in the row below.

## 2.2 Additional display information

### DRC-DR radio receiver display

Battery capacity

Display of selected travelling hoist(s)

2nd main row with alpha-numerical display

Load-proportional bar display

Crane identification

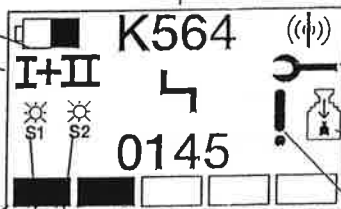

Icons for switching statuses of universal output

Radio signal quality

Display of service interval

1st main row with large icon or numerical display

Load reduction icon

Safety function off icon

42694144.eps



### Display of service interval

This icon indicates that the Demag Service or a service company authorized by Demag must be called in for service work.

## Icons in the first main row



### Fault icon

The fault icon is displayed in the event of a fault.

The code of the fault is displayed in the row below. If there are several faults at the same time, the code displayed changes in cycles.



### Overload icon

The overload icon is displayed in the event of an overload. The load of the selected travelling hoist(s) is also displayed in the row below if the hoist is fitted with ZMS.



### Brake icon

The brake icon is displayed, if the additional brake has been applied.



### “Universal output 1 switching status” icon

This icon is displayed when universal output 1 is active. The function of this output can be programmed.



### “Universal output 2 switching status” icon

This icon is displayed when universal output 2 is active. The function of this output can be programmed.



### “Important. Safety function de-activated” icon

This icon indicates that a function relevant for safety such as load reduction or by-pass control has been de-activated by the operator.



### “Load reduction active” icon

The icon indicates that load reduction is active. As long as load reduction is active, only the reduced load (specified by a parameter) can be lifted.



## Load-proportional bar display

The load-proportional bar display shows the load on the crane in five increments of approx. 20 %. This display is independent of the travelling hoist selection and always refers to the max. possible load.

### 5.3 Identification labels for the crane installation

Every crane with wireless control must be identified by means of an easily visible crane identification/number. Travel direction symbols on the crane and the travelling hoist must identify the movement directions of the travel motions in line with the identification of the keys on the hand-held control system.

#### 5.3.1 Coding labels

The coding labels are used for illustration of the crane identification on the travelling hoist or on the crane. The crane identification illustrated by means of the coding labels must be identical with the crane identification shown in the display of the DRC-10 hand-held transmitter.

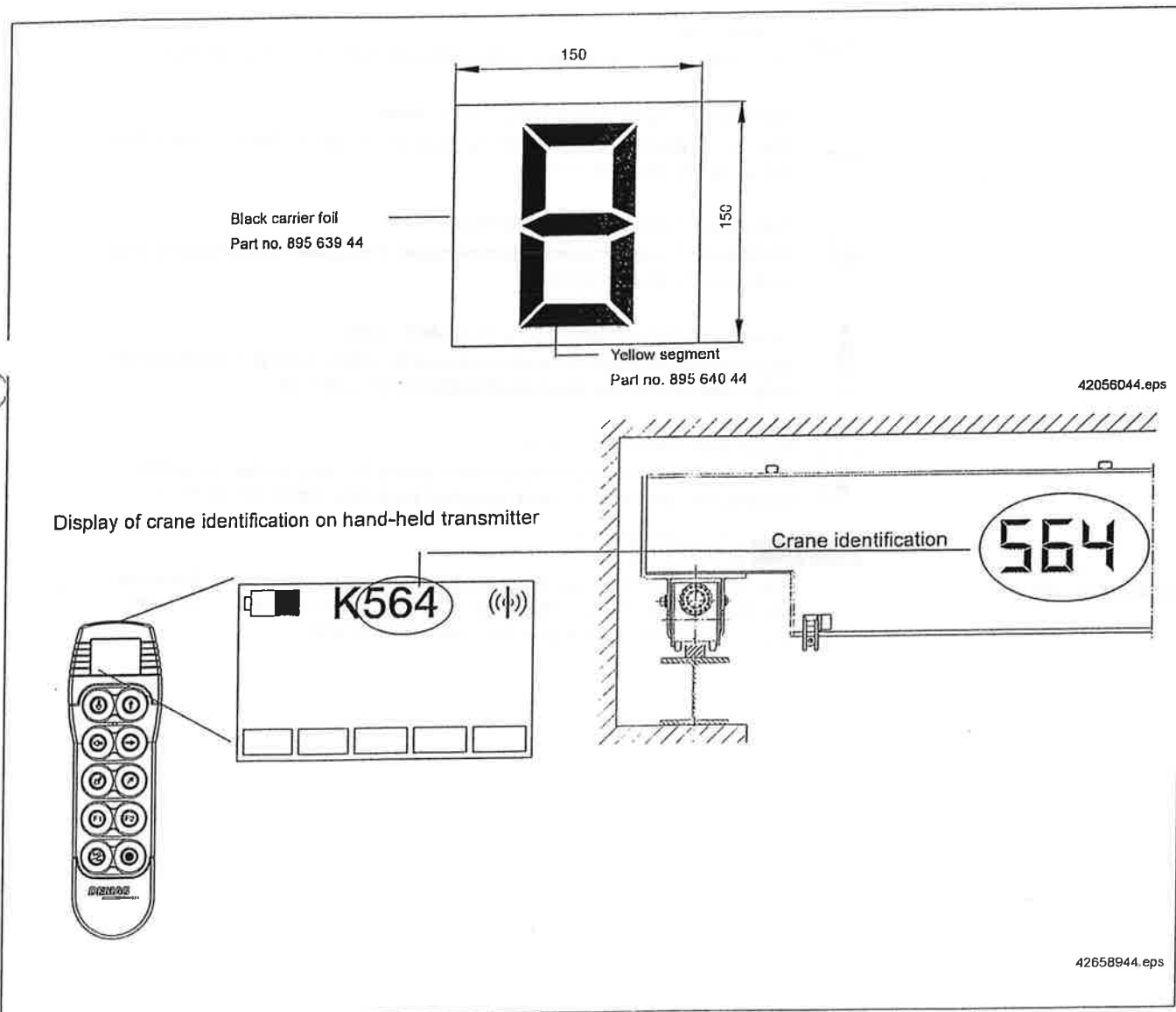

The coding labels (dimensions 150 x 150 mm) (black background foil + foil with number) must be fitted on the hoist unit in such a manner that they are easily visible. Numbers 1 to 9 are produced by removing the yellow segments.

### 5.3.2 Travel direction symbols

Cross-travel speed  
Part no.: 895 635 44

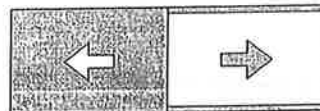

Long-travel speed  
Part no.: 895 637 44

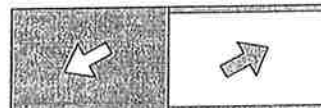

The direction labels must be fitted to the hoist unit in an easily visible manner, matching the movement of the drive and in line with the direction symbols on the transmitter.

## 6 Putting the radio control system into operation after installation

### 6.1 Putting into operation

A radio control system has been put into operation when the hand-held transmitter has been put into operation. The following preparation measures are necessary:

#### 6.1.1 Charging the batteries before putting the unit into operation for the first time

The scope of delivery of the DRC-10 hand-held transmitter includes a separate rechargeable battery. It must be inserted in the battery compartment of the hand-held transmitter ensuring the correct pole arrangement (see also illustration in section 7.4.5).

Since new rechargeable batteries are only partially charged, they must be charged before the unit is put into operation for the first time by connecting them to the plug-in charger (see section 8.2).

**If no battery icon is displayed when the hand-held transmitter is activated, the batteries are completely discharged. In this case, the batteries must be charged in the enclosed plug-in charger.**

#### 6.1.2 Assembly and connection of the radio receiver

Demag DRC-MP or DRC-DR radio receivers must be fitted in accordance with the relevant operating instructions and connected in accordance with the circuit diagram of the installation. Comply with the instructions and measures described in the operating instructions for putting the radio receiver into operation.

#### 6.1.3 Applying the crane identification on the crane

A unique crane identification/number must be selected (recommended: a 3-figure number) and fitted to the crane in accordance with section 5.3 for the crane fitted with the radio control system.

### 6.2 Putting a radio remote control system with DRC-10 into operation

Following these preparation measures, put the hand-held transmitter into operation by logging it on to the radio receiver of the crane to be controlled. Following this procedure, the radio control system is configured for the specific application.

The Demag DRC-MP or DRC-DR radio receiver on the crane must be supplied with power, be ready for operation and within the range of the hand-held transmitter.

#### 6.2.1 Switching on the hand-held transmitter

When the unit is switched off, there are no icons in the display, the LED is off. To switch on the hand-held transmitter, actuate the Stop key.

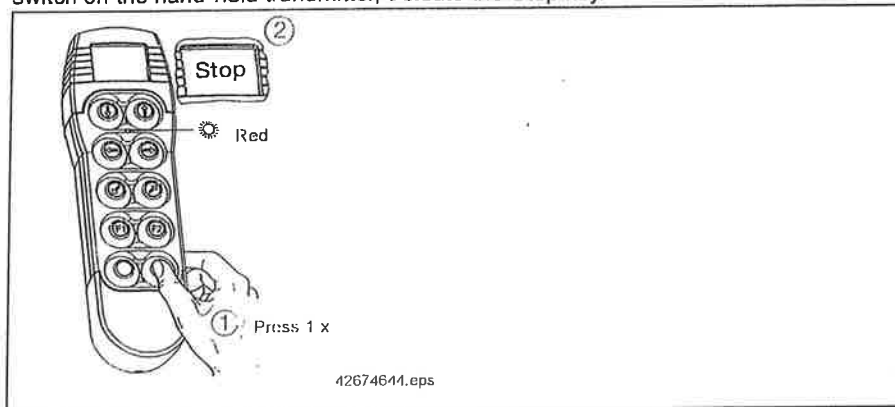

The DEMAG logo is displayed first. The DRC-10 hand-held transmitter scans the radio channels for controllable radio receivers and searches for an assigned radio receiver. Before the hand-held transmitter has been put into operation for the first time, it has no radio receiver assigned, therefore you can expect the following display:

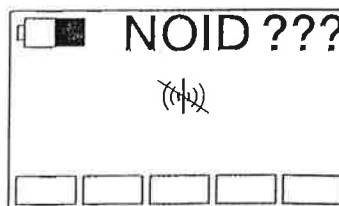

If the transmitter has already been assigned to a receiver in the log-on steps as described in section 6.2.2, you can expect the following display:

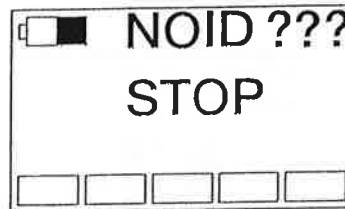

42694344.eps

In this case, continue putting into operation with the assignment of the crane identification, see section 6.2.3.

Note: Additional information may also be shown in the display depending on the type of crane control system.

### 6.2.2 Log-on of hand-held radio transmitter



Logging on hand-held transmitter as described in the following is a safety-relevant process that may only be carried out by authorized and instructed expert personnel.

Important:

Each receiver is assigned a crane identification when it is put into service (see section 6.2.3).

This crane identification must be shown in a clearly visible manner on the travelling hoist or crane by means of coding labels. When a new hand-held transmitter is logged on, the crane identification shown on the hand-held transmitter must match the coding labels on the crane (see section 5.3).

Correct assignment between the transmitter and the crane must be checked by actuating the horn before any crane motion is actuated.



If the correct assignment is not checked, unintended crane movements may cause serious damage and injuries, even resulting in death.

Log-on of a DRC-10 hand-held transmitter to a DRC-MP or DRC-DR radio receiver establishes the assignment between the relevant hand-held transmitter, the controlled radio receiver and the crane that is unique world-wide. The transmitter and the receiver are provided with unique address features that are exchanged during the log-on process and ensure clear and unique assignment. During the log-on steps, the crane identification (see sections 5.3 and 6.2.3) is also transmitted from the receiver to the hand-held transmitter and is saved. DRC-10 hand-held transmitters show this crane identification/number so that the operating personnel can identify the controlled crane.

Log-on is activated in Run mode or STOP mode.

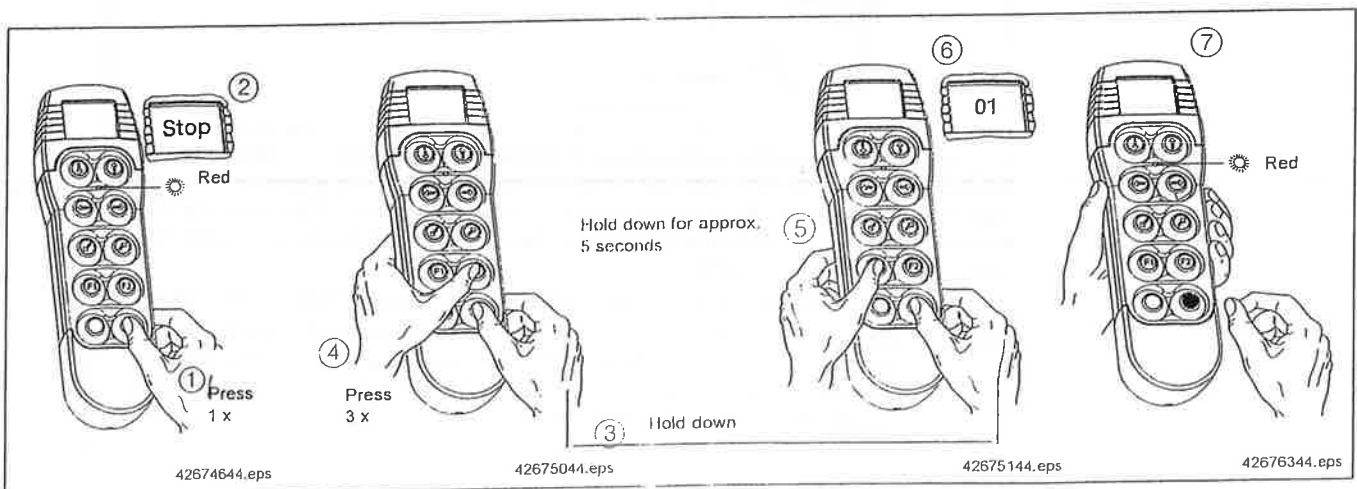

Following activation, a two-digit number is shown in the first main row which indicates the number radio receivers that can be controlled and are within range. (In the example, 01 controllable receiver is shown.)

**Select radio receiver based on crane identification**

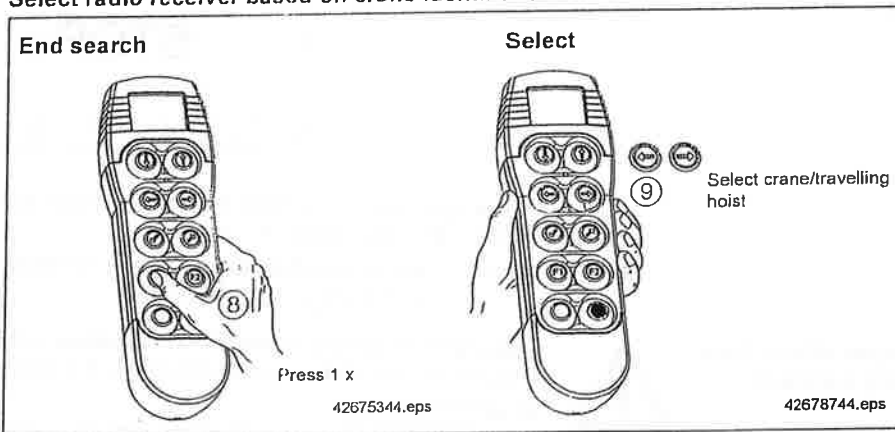

After starting selection with F1, the crane identification of the controllable radio receivers can be displayed one by one by scrolling with the Left and Right keys

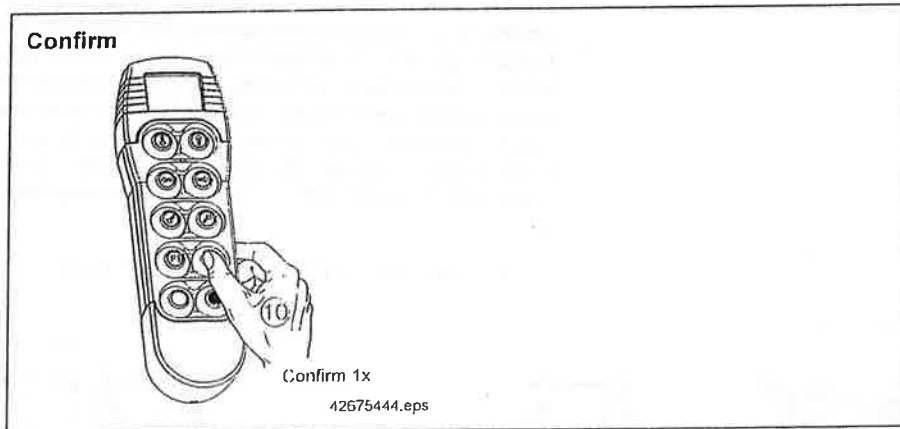
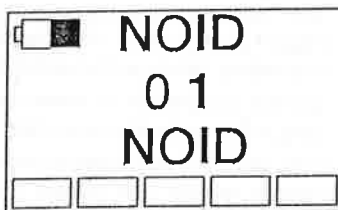

By pressing the F2 key for confirmation, the hand-held transmitter is assigned to the DRC-MP or DRC-DR radio receiver whose crane identification is shown in the second main row of the display (NOID in the example). At the same time, the crane identification of the DRC-10 hand-held transmitter is also changed to the new value and displayed next to the battery icon.

Log-on of the hand-held radio transmitter is then completed by actuating the Lift key.

**Note:** Log-on of the DRC-10 hand-held transmitter to a DRC-MP or DRC-DR radio receiver with code NOID is only necessary when the unit is put into operation for the first time in order to assign the crane identification determined in section 6.2.3 to the receiver.



### 6.2.3 Assignment of crane identification/number for the radio receiver

**Important:** The assignment of the crane identification described in the following for putting the radio receiver into operation is a safety-relevant process that may only be carried out by authorized expert personnel.

After successful establishment of a radio connection between the DRC-10 hand-held transmitter and the DRC-MP or DRC-DR radio receiver, the crane identification determined acc. to section 5.3 must be assigned to the radio receiver. As long as the radio receiver operates with code "NOID", no movement commands are output to the crane control system. (To check radio transmission in this status, use the signal key if Run mode has been activated.)

#### Activating the assignment

Assignment is activated in STOP mode or Run mode.

- Actuate and hold down the STOP key
- Actuate the Lower key
- Actuate the Right key twice
- Hold down the Lower key for 5 seconds, until the display changes
- Release the Lower key
- Release the STOP key

The following display appears

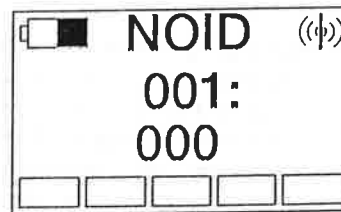



42694544.eps

**Note:** Additional information may also be shown in the display depending on the type of crane control system.

The code no. of the displayed parameter is shown in the first main row.  
The value of the parameter is shown in the second main row.

#### Selection of parameter 004 for the crane identification/number

- Right key  increases the displayed code no.
- Left key  decreases the displayed code no.

#### Entry of the crane identification/number

First select parameter 004, then actuate the F1 key to start entry. The following display appears

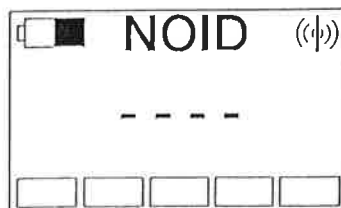

42694644.eps 25

Four free digits for entry of the crane identification/number are highlighted in the first main row. The first digit is preselected. Use the right and left keys to select a number/character from the available set of characters. Press the F1 key to accept the selected character and to change to the next position.

#### Transmitting the assigned crane identification

When the appropriate crane identification has been entered, press the F2 key to confirm and to transmit it to the crane receiver. This crane identification is then saved in the radio receiver. The hand-held transmitter will keep and display its old crane identification (NOID) until the hand-held transmitter has been logged on for the radio receiver with the new crane identification as described in 6.2.2.

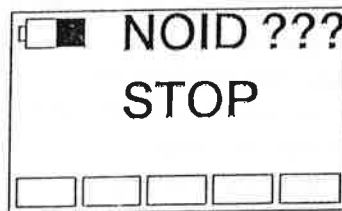

42694344.eps

#### Cancelling/ending assignment of the crane identification

The entry can be cancelled at any time without changing the crane identification by actuating the Lift key. Entry is completed by actuating the F2 key. Then use the Lift key to exit the assignment menu.

**Important:** After changing the crane identification for the receiver, log-on of the hand-held transmitter must always be carried out (section 6.2.2) so that the new crane identification is displayed on the hand-held transmitter.

### 6.3 Configuration of a radio remote control system for DRC-DR

DR cranes that are provided with the DRC-DR radio receiver use an extended scope of functions of the DRC-10 hand-held transmitter for configuration of the crane control system and to display information. Additional instructions and information are described in the operating instructions of the Demag DRC-DR radio receiver (ident. no. 214 953 44) for putting a crane with the DRC-DR radio receiver into operation.

## 7 Operation of the radio control system

The operator controls the radio-controlled crane by means of the DRC-10 hand-held transmitter.

### 7.1 Checks before starting work

Before starting work, the operator must carry out the inspections and function checks listed in the crane operating instructions and must be satisfied that the installation is in safe operating condition.

#### 7.1.1 Switching on the hand-held transmitter when starting work

When the unit is switched off, there are no icons in the display, the LED is off. To switch on the hand-held transmitter, actuate the Stop key.

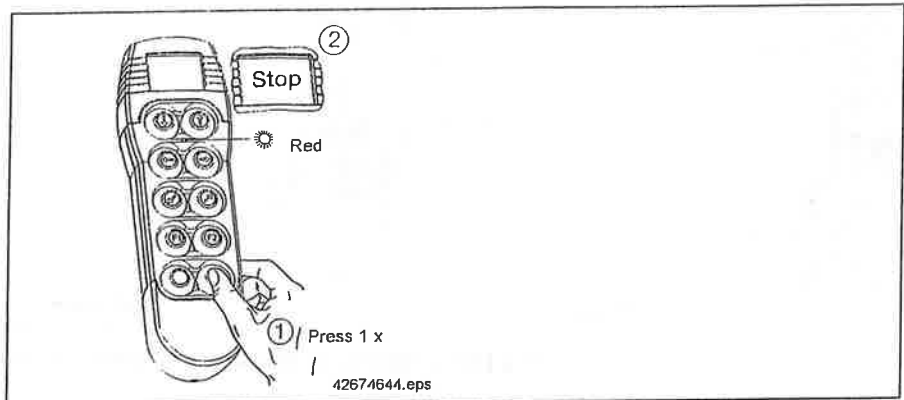

The DEMAG logo is displayed first. When the connection to the radio receiver has been established, the following displays must be shown:

- Crane identification of the assigned radio receiver
- Icon to display the radio signal quality
- Icon to display the battery capacity
- Bar display
- STOP



**Note:** If the hand-held transmitter was connected to the charger before starting work or was switched to standby mode in any other way, the electronic switching-on key must be entered for switching the unit on, see section 7.2.1.

#### 7.1.2 Checking the radio system

The radio system performs a self-test when it is switched on. The installation is then ready for operation if no error statuses are displayed. Fault elimination is described in section 11.

In addition, the crane operator must check the following before starting work:

- Battery capacity 8.1
- Quality of radio connection 5.2.1
- Displayed crane identification and relevant crane 5.2.1
- Function of signal/horn 5.1
- STOP key function 2.7

To check functioning of Signal and STOP, crane operation must be switched on.

## 7.2 Crane operation/Run

Run mode of the radio system must be started for crane operation. To do this, the electronic On key must be entered. The On key is used to

- Switch from Standby (lock icon) to Run mode.
- Switch from STOP to Run/crane operation mode.

### 7.2.1 On key

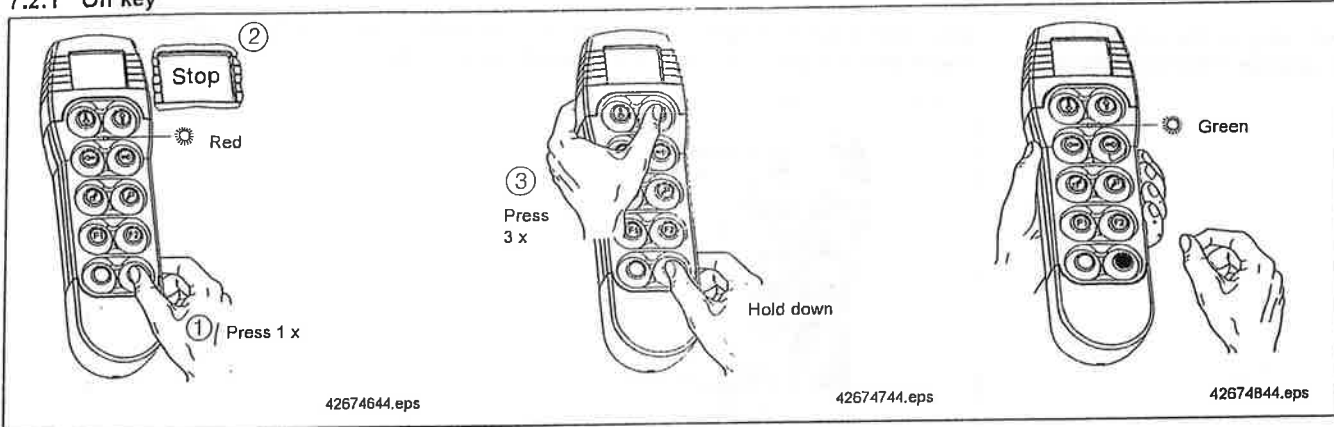

The LED in the display field flashes green if Run mode is switched on after entry.

### 2 Functions in crane operation

In Run mode, the hand-held transmitter can be used like a cable-connected control pendant (see figure in section 5.1). For every motion axis of the crane (hoist, cross travel, long travel) a pair of self-resetting keys is available.

Each of the keys that are arranged next to each other controls one movement direction.

Key actuation is stepless after the switch-on threshold to enable control of switched or speed-controlled drives, depending on the design of the crane control system.

If both directions of are pressed at the same time, the movement is stopped. To restart the movement, both keys must first return to the rest position.

### 7.2.3 STOP function

The STOP key identified in red results in a STOP command which stops the movements of hoist, cross travel and long travel at the same time and triggers an emergency-stop in the crane control system.

To avoid danger, the crane operator can immediately stop all movements by means of the STOP key. The braking process caused by an EMERGENCY stop can result in load sway.

The STOP key is also intended to be used for switching the radio-controlled crane into a safe status. This method is to be used when interrupting work and for starting additional functions of the hand-held transmitter for displaying information and servicing purposes.

When STOP has been actuated, crane operation can only be re-activated by entering the electronic On key.

To obtain increased safety, the STOP key is of two-stage design. For entry of the On key, both switches must be actuated for a successful check of the function.

### 7.2.4 Signal key

The signal key is of two-stage self-resetting design. The first stage activates the acoustic signal in the crane receiver. The second stage activates an additional signal for the crane control system to carry out the hoist limit switch test. For checking the limit switch, the instructions contained in the operating instructions of the radio-controlled crane must be applied.

### 7.2.5 F1 and F2 function keys

The function keys are of single-stage self-resetting design. Various additional functions are controlled depending on the design of the radio receiver and the crane control system. These functions are described in the operating instructions of the receiver or the crane installation.

## 7.3 Taking the unit out of service at the end of the shift (standby)

At the end of the shift or in the event of extended breaks, DRC-10 hand-held transmitters must be switched to Standby mode by the illustrated key sequence to protect the installation against unauthorized use and to reduce power consumption of the DRC-10 hand-held transmitter. The time after the end of the shift or longer breaks should be used to re-charge the batteries by connecting them to the charger unit.

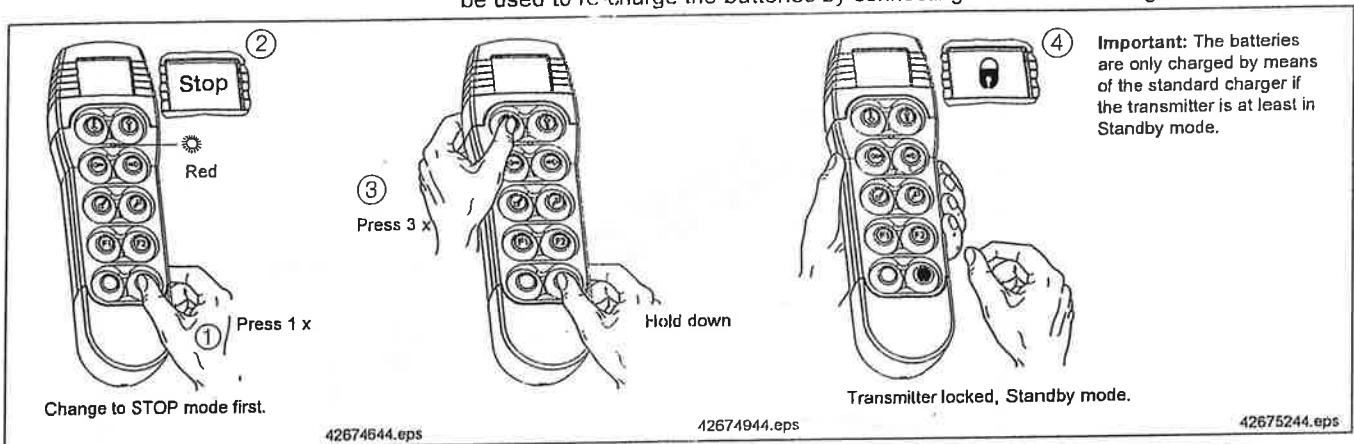

### 7.3.1 Storage of hand-held transmitters that are not in use

If a hand-held transmitter is not used for some time (several weeks), the batteries should first be fully charged and then removed from the hand-held transmitter (see section 7.4.5). The batteries can be stored for several months when they are charged. If required, the charging process should be repeated after some time.

## 7.4 Operating statuses of the radio control system

The function and display of the radio control system are determined by the operating status of the hand-held transmitter. The operating status of the transmitter is transmitted to the crane control system.

### 7.4.1 Hand-held transmitter switched off

Display and radio connection are de-activated. Power consumption of the hand-held transmitter in this status is less than the natural discharge of the batteries. Switch on the hand-held transmitter and briefly actuate the STOP key.

### 7.4.2 STOP mode

After switching-on, the hand-held transmitter is in Stop mode, the LED in the transmitter is permanently lit red.

The display shows STOP. No travel commands are transmitted in STOP mode. The EMERGENCY stop contact in the receiver (crane switch for DRC-DR) is open.

The radio connection to the receiver is maintained. Following a timeout period of 5 minutes without any key actuation, the hand-held transmitter will automatically switch to Standby mode.

### 7.4.3 Run mode

The LED in the keyboard flashes green. The crane identification of the assigned crane and the icon for the radio connection are shown in the display. In Run mode, the hand-held transmitter is fully functional for crane operation, see section 7.2.

Crane operation can be started with the On key in "STOP" and "Standby" mode, see section 7.2.1.

Following a timeout period of 30 minutes without any key actuation, the hand-held transmitter will automatically switch to Standby mode.

#### 7.4.4 Standby mode

The display shows the lock icon. No radio connection is displayed. In standby mode, power consumption of the transmitter is strongly reduced and the radio connection is de-activated.

The operator can switch on Standby mode by using the switch-off procedure, section 7.3, and by plugging-in the charger.

Standby is automatically switched on by the timeout function as described in sections 7.4.2 and 7.4.3.

The operator can end Standby mode only by entering the On key, section 7.2.1, and then change to Run mode.

#### 7.4.5 Resetting the hand-held transmitter

The hand-held transmitter may need to be reset if software errors occur.

The hand-held transmitter can be reset by removing a battery for a short time.

The batteries can be reached by carefully pulling off the lower rubber cap.

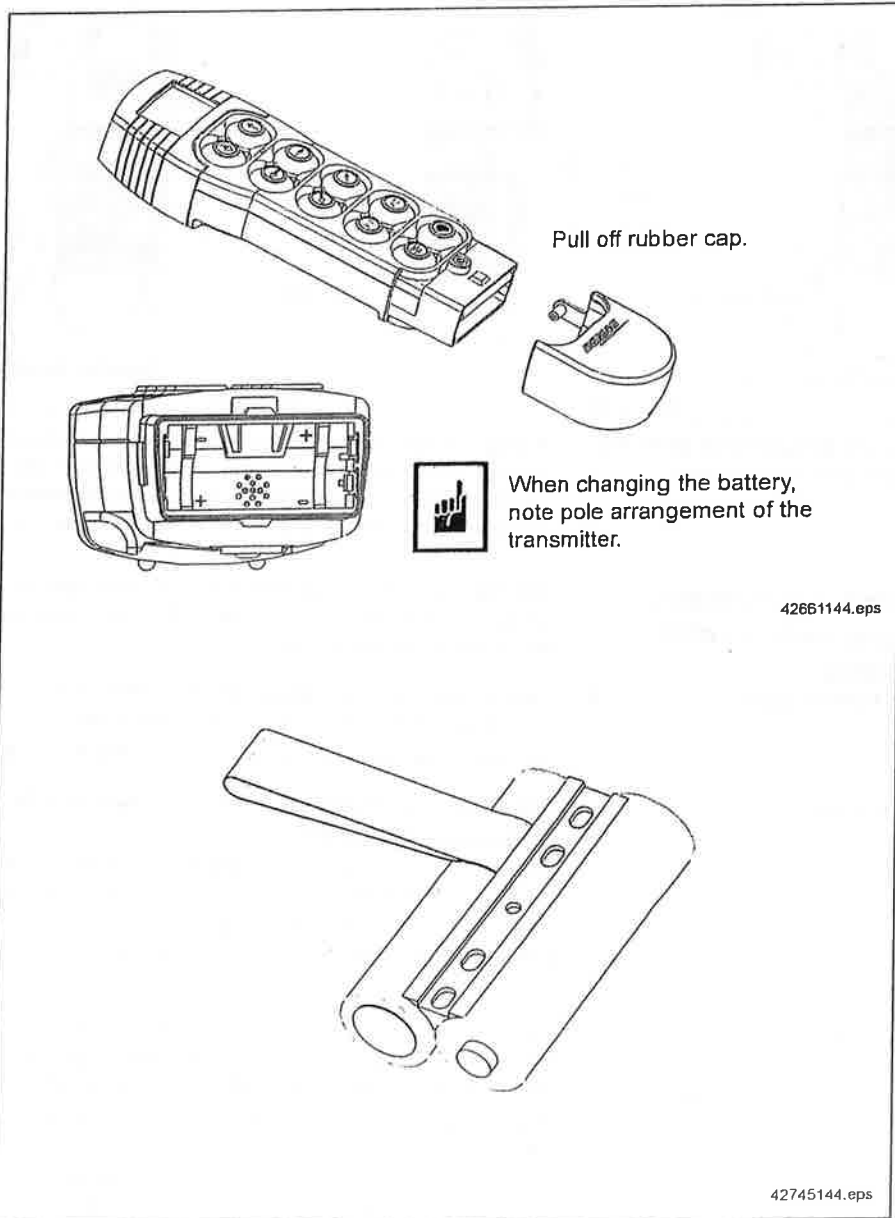

## 8 Power supply of the hand-held transmitter

The hand-held transmitter is supplied with power by means of the rechargeable battery pack included in the scope of supply or by two NiMH rechargeable batteries, size AA (LR6). The batteries must be charged in good time by means of the appropriate plug-in charger. The ambient temperature must be between 10° C and 45° C for the charging process.

### 8.1 Display of available battery capacity

The battery capacity is shown in the display of the hand-held transmitter. The charging status of the battery corresponds to the filled surface in the battery icon.

For a new battery, the completely filled battery icon means a useful operating time of the switched-on hand-held transmitter (Run or STOP) of at least 8 hours.

If only residual charge is displayed, connect the hand-held transmitter to the charger as soon as possible. If the battery icon is empty, the hand-held transmitter must be immediately connected to the charger.

The operating time that can be reached for the hand-held transmitter with one battery charge depends on the operating mode of the hand-held transmitter, the ambient temperature and the age of the batteries.

If the hand-held transmitter is continuously switched on, 8 hours of operation can be achieved with one battery charge.

The following measures reduce power consumption:

- Actuate the STOP key, when the crane is not used,
- Switch the transmitter off by changing to Standby during breaks in operation.

### 8.2 Charging the batteries

 When this battery icon is displayed, immediately charge the integrated batteries by means of the plug-in charger included in the supply.

If the batteries are not charged immediately, the battery icon starts to flash and the hand-held transmitter is switched off after a few seconds.

Quick charging of the batteries with the hand-held transmitter is only possible at ambient temperatures from 10 °C to 45 °C. If the temperature is higher or lower than this range, the charging process is aborted and the system automatically switches over to trickle charging.

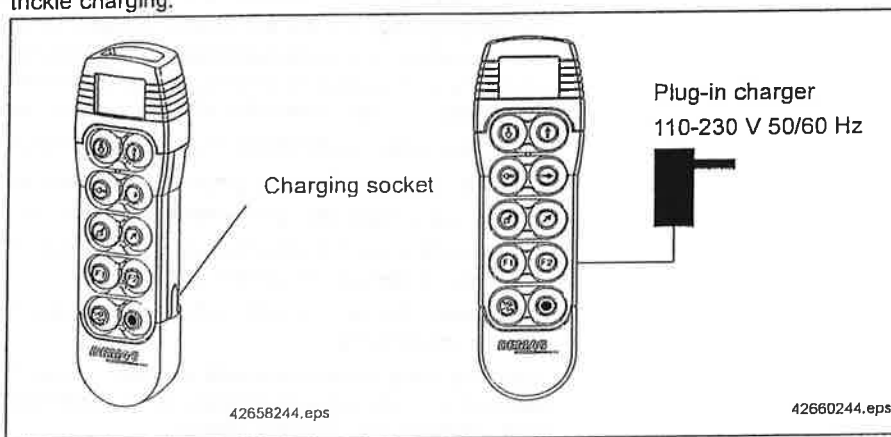

#### Important:

The rechargeable batteries integrated in the transmitter may only be charged with the original plug-in charger unit. The use of other charger units may result in permanent damage to the transmitter.

The charging process is monitored and controlled by the electronics in the hand-held transmitter. Partly discharged batteries can also be charged.

Plug charger into a power socket and connect the connection cable in the charger socket of the hand-held transmitter – the battery icon is animated during the charging process and fills in cycles. 

When the charging cable is connected, the hand-held transmitter changes to standby mode.

The charging process comprises quick charging and trickle charging mode.

**Quick charging mode:** This process takes approx. 2 h, if the battery is empty, it charges the battery to approx. 80 %.

**Trickle charging mode:** After quick charging, the system switches over to trickle charging mode with a lower charging current so that the hand-held transmitter can remain connected to the charger for any period of time.

 Icon when the charging process has been completed.

 Icon for battery errors.

This icon appears, if a battery problem has occurred, e.g.:

- The batteries are defective,
- The batteries are too old,
- Non-rechargeable batteries are attempted to be charged.

Defective batteries must be replaced by new rechargeable batteries (see section 8.3).

**Important note:** To ensure sufficient charging of the batteries when they are empty, it is necessary to connect the hand-held transmitter to the charger for min. 2 h. The display of the filled battery icon after disconnecting the charger connector is not sufficient, it is already reached after a brief charging time.

## 8.3 Replacing the batteries

The rechargeable batteries in the hand-held transmitter are subject to ageing as a consequence of charging/discharging cycles and continuously lose charging capacity. We recommend that the rechargeable batteries be replaced after one year, at the latest. A rechargeable battery must be immediately replaced if the relevant icon for a failure in the battery is displayed.

The NiMH rechargeable batteries supplied with the hand-held transmitter have been specifically selected for the requirements of this radio control system. The electrical and mechanical features of the hand-held transmitter and rechargeable batteries have been matched to fulfill all requirements of trouble-free and safe operation.

For replacement, use the specified rechargeable battery pack, part no. 773 499 44. The use of non-approved rechargeable batteries may result in hand-held transmitter operating malfunctions or lasting damage to the charger and the hand-held transmitter. In addition, comply with the following when replacing rechargeable batteries:

- Always replace both rechargeable battery cells at the same time
- Make and type of both rechargeable batteries must be identical
- Only use completely new rechargeable batteries
- Both rechargeable batteries must have the same charging status (do not combine charged batteries with uncharged ones)
- Polarity of the rechargeable battery cells in accordance with the marks in the battery compartment.

When replacing the rechargeable batteries, check the contacts in the battery compartment for sufficient contact pressure. The new rechargeable batteries must fit tightly between the contact surfaces.

In exceptional situations, when no charged batteries are available, the hand-held transmitter may be operated with two 1,5 V primary cells size AA (LR6) according to EN/IEC 60086. We recommend that alkaline batteries, such as Duracell and Varta brands, be used. Primary cells cannot be recharged.



If primary cells are used in the hand-held transmitter, it must not be connected to the charger to avoid damage caused by overheating during the charging attempt.

Used rechargeable batteries and primary cells must be disposed of in accordance with environmental protection regulations.



## 9 Information menu in connection with DRC-DR

This additional function of the hand-held transmitter can only be used in connection with a DR rope hoist and CAN bus.

The Information menu makes the display of information on the crane or the travelling hoist(s) possible. This information is stored in the form of a list by each DR control system. One element of this list is requested by the hand-held transmitter and made available by the selected control system via the CAN bus.

### 9.1 Activating the Information menu

- Actuate and hold down the Stop key
- Actuate stage 1 of the Horn key twice
- Actuate stage 1 of the Horn key again and hold it down for approx. 5 seconds
- Release the Horn key again
- Release the Stop key

### 9.2 Selecting the information source

Selection of the polled control system is analogue to travelling hoist selection. Since the F1 key has no function in the information menu, the travelling hoist must first be selected in the Run operating mode:

Travelling hoist selection	Information from
I	Travelling hoist 1 control system
II	Travelling hoist 2 control system
I+II	Crane control system

### 9.3 Activating the display travelling hoist selection

If there is only one travelling hoist on the crane, no travelling hoist selection is necessary, thus no travelling hoist selection is displayed on the hand-held transmitter. If travelling hoist selection is nevertheless to be activated, this can be done by holding down the F1 key for approx. 5 seconds.

### 9.4 Starting screen

After changing to the Information menu, the starting screen of the Information menu is shown in the display of the transmitter. This starting screen shows information START II (since travelling hoist 2 has been selected) and code 888:

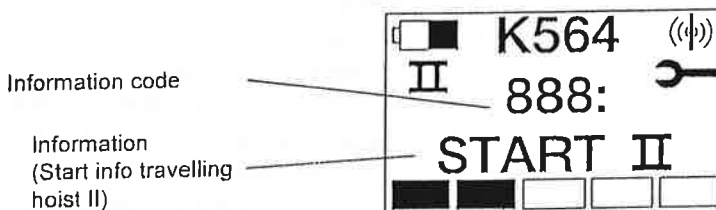

42660744.eps

### 9.5 Navigating in the information menu

To navigate in the information list, use the following keys:

Key	Function
Right	to the next value in the list
Left	back to the previous value in the list
Lift	exit the Information menu

## 9.6 Data of the Information menu

The following data can be displayed via the Information menu:

Code	Information
401	Remaining duration of service in % (determined from load spectrum), not available for DR-Com rope hoists
400	Operating hours
000	Basic value for full load hours with reference to rated load for size
001	Gearbox transmission ratio
002	Drum diameter
003	Reeving factor
004	Control type (travelling hoist or crane control)
005	Solo travelling hoist (with/without crane control)
146	Customer number
147	Order number
148	Serial number
149	Year of manufacture
150	Hoist speed V1
151	Hoist speed V2
152	Lifting height
153	Reeving
155	Rope diameter
171	Country code
216	Serial number of control system
217	Hardware version
520	Software version of main controller
529	Software version of monitoring controller

The following additional information is available with the "Status analysis" option:

Code	Information
402	K1 switching operations
403	Hoist brake switching operations
404	Travel path in m
405	K2 switching operations
406	K3 switching operations
416	Number of times slip limit is exceeded
417	Number of times max. speed is exceeded
418	Number of hoist brake errors
419	Number of times the overspeed brake is triggered
420	Number of overloads
421	Number of emergency stop actuations during motion of min. one axis
448	Last error
449	Penultimate error

Sequence and quantity of information depend on the software and may be changed.

The following example shows the remaining duration of service:

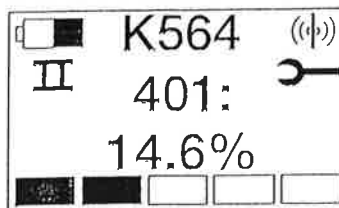

# 10 Technical data

<b>Operating elements</b>	- Keys	6 stepless
	- STOP key	1 (2-stage)
	- Signal / check key	1 (2-stage)
	- Keys for special functions	2 (1-stage)
<b>Indicators</b>	- LCD, illuminated	graphical, 35 x 25 mm
	- LCD, functioning temperature	0 °C to 55 °C
<b>Radio transmission</b>	Transmitter power	12 ± 2 dBm
	Typical range	approx. 100 m
	Frequency range	903.00-926.120 MHz
<b>Housing</b>	Type of enclosure	IP 55
	Weight of transmitter with battery	500 g
	Weight of transmitter w/o battery	445 g
<b>Transformer/charger</b>	Supply voltage	110 - 230 V, 50/60 Hz
<b>NIMH rechargeable battery</b>	Model	AA (LR6), IEC 60086
	Capacity:	2100 mAh
	Service life of battery	500 charging cycles acc. to IEC 509
	Temperature range	
	- Quick charging	10 °C to +45 °C
	- Charging	0 °C to +45 °C
	- Discharging	-20 °C to +50 °C
	Charging time	approx. 2 hours
	Weight	55 g
<b>Operation with one battery charge</b>	- 100 % Run mode	min. 8h
	- 50 % Run - 50 % Standby mode	min. 16h

## 10.1 Dimensions

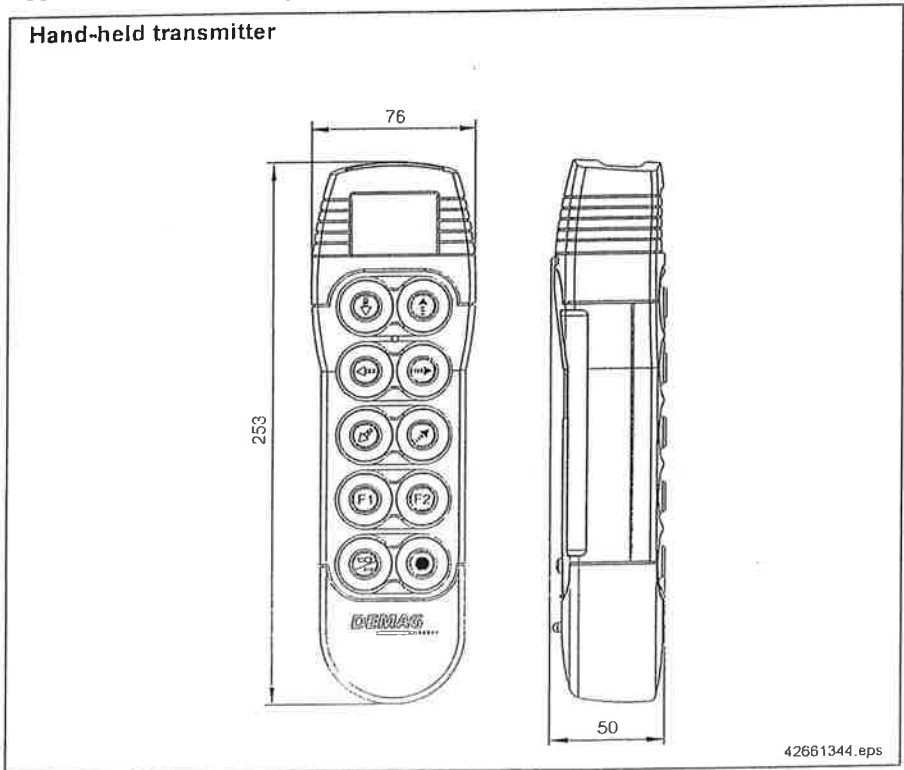

## 10.2 Postal approval



Postal approval is valid for USA and Canada.  
Approval # still to be provided.

# 11 Eliminating faults

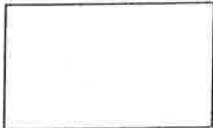
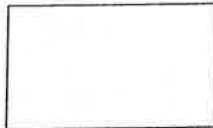
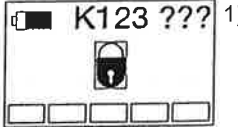
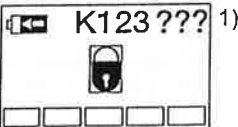
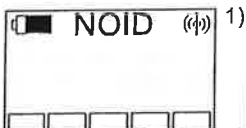
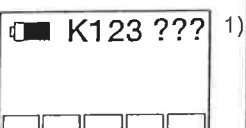
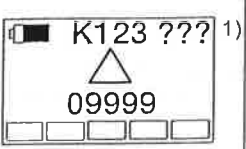
Before eliminating faults by measures on the radio control system, check that the crane installation is supplied with power and is ready for operation and has not been switched off by safety devices. (Mains connection switch, crane isolating switch, emergency-stop switch, travel and lifting path limitation devices, overload protective device, motor protective switch, etc.)

No.	Problem	Display	Possible causes	Notes, section in this document
01	Hand-held transmitter cannot be switched on with STOP key	 LED Off	Power supply of the hand-held transmitter has failed	Check rechargeable batteries, see section 8. Polarity of batteries? Replace completely discharged batteries.
02	Hand-held transmitter cannot be switched on with STOP key	 LED Off	Hand-held transmitter has failed	Replace hand-held transmitter
03	Hand-held transmitter cannot be switched on with STOP key	 LED Off	Standby mode	Switch on with electronic key, see section 7.2
04	Hand-held transmitter does not respond to key actuation	 LED Off	Battery is being charged	End charging procedure, 8.2. Switch on with electronic key, 7.2
05	Crane does not respond to key command	 LED Green, flashes	Assignment of crane identification is missing	Horn is working, assign crane identification, 6.2.3
06	Crane does not respond to key command	 LED Green, flashes	Assigned crane receiver has no power supply	Switch on crane; check crane receiver acc. to operating instructions
07	Warning during start of crane operation	 LED Green, flashes	Re-establishing radio connection after: - Malfunction in DRC-MP receiver - Timeout of hand-held transmitter - Range limits exceeded or Auto-power-off - Power-Down: Short-term undervoltage or voltage failure on the receiver side. - After log-on of a new transmitter	Acknowledge warning with STOP key. Restart with On key 7.2.1

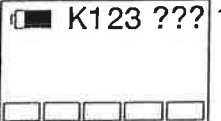
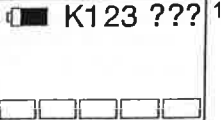
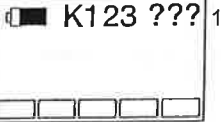
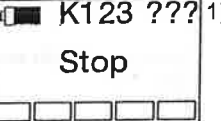
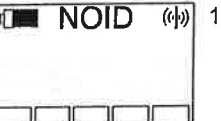
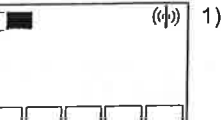
1) Additional symbols may also be shown in the display field

Problem	Display	Possible causes	Notes, section in this document
08 The displayed crane does not respond	 <p>LED ◊ Green, flashes</p>	Another hand-held transmitter has been logged on for the crane	Take the other hand-held transmitter out of service, 7.3. Log-on hand-held transmitter again, 6.2.2.
09 The displayed crane does not respond	 <p>LED ◊ Red</p>	Power supply of receiver interrupted	Actuate STOP key, then enter On key, 7.2.1. No. 06 or 10 is then possible.
10 The displayed crane does not respond	 <p>LED ◊ Green, flashes</p>	Crane receiver outside range of transmitter	Reduce distance to crane, 2.7 and 5.2.1 Check radio reception by means of log-on procedure 6.2.2. Check aerial connector on receiver.
11 Crane does not respond to key command	 <p>LED ◊ Red</p>	STOP mode	Enter On key, 7.2.1.
12 The crane identification displayed on the transmitter is incorrect	 <p>LED ◊ Green, flashes</p>	The crane identification of the receiver was changed with the hand-held transmitter	Safety problem: A crane that is not displayed is being controlled. Actuate signal to identify the crane. Log-on hand-held transmitter, 6.2.2
13 The crane identification is missing in the display	 <p>LED ◊ Green, flashes</p>	The crane identification of the receiver was changed with the hand-held transmitter	Safety problem: A crane that is not displayed is being controlled. Actuate signal to identify the crane. Log-on hand-held transmitter, 6.2.2
14 Hand-held transmitter does not respond to key actuation	Any malfunctioning display	Software crash	Reset hand-held transmitter, 7.4.5. Then switch on with STOP.
The batteries are not being charged	 <p>LED ◊ Off</p>	Hand-held transmitter is switched off	Switch on with STOP key, 8.2. 01 is then possible

1) Additional symbols may also be shown in the display field

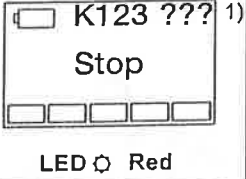
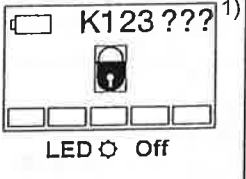
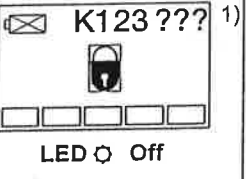
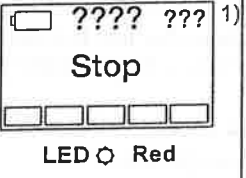
No.	Problem	Display	Possible causes	Notes, section in this document
16	The batteries are not being charged		No power from charger	Check connection to charger and mains connector. Replace defective plug-in charger, if necessary.
17	The batteries are not being charged		No power from charger	Check connection to charger and mains connector. Replace defective plug-in charger, if necessary.
18	The batteries are not being charged		Defective rechargeable batteries	Replace rechargeable batteries, 8.2 and 8.3.
19	Receiver does not respond		No receiver assigned. Repeat log-on procedure	See section 6.2.2
20	Operating time with charged batteries too short	Battery display changes to uncharged within a short time.	Charging procedure aborted. The batteries are worn out/too old.	Repeat charging procedure, 8.1 and 8.2

1) Additional symbols may also be shown in the display field

Please contact Demag customer service if the measures above do not eliminate the fault.

**DEMAG**

Cranes &amp; Components

**EC conformity declaration**  
Demag radio control systemin accordance with EC directive 89/336/EEC, Appendix I, 73/23/EEC,  
Appendix III and 99/5/EC

1 page(s) Page 1

Ident. no.

205 331 44

Issue 0107

EN

Hereby we,

**Demag Cranes & Components GmbH**

declare that the product

**Demag radio control system RC-10, RC-J,  
DRC-10, DRC-J,  
DRC-MP, DRC-DR, DRC-DC 1)**

of serial design is in conformity with the provisions of following relevant regulations:

EC EMC directive 89/336/EEC  
 amended by 91/37/EEC and 93/68/EEC  
 EC Low Voltage Directive 2006/95/EC  
 EC LVD and TTE directive 99/5/EG

Applied harmonised standards:

EN 954-1	Safety related parts of control systems
EN 13557	Control elements and control positions
EN 50178	Electronic equipment for use in electrical power installations and their assembly into electrical power installations
EN 60204-32	Electrical equipment, requirements for hoists
EN 60529	Types of enclosure (IP code)
EN 61000-6-2	Electromagnetic compatibility – Immunity for industrial environments
EN 61000-6-4	Electromagnetic compatibility – Emission standard for industrial environments
EN 300220-3	Electromagnetic compatibility and Radio spectrum Matters (ERM); Short Range Devices (SRD)

Wetter, 16 January 2007

Place and date of issue

ppa. Gersemsky  
Technik Handling Technologyppa. Hoffmann  
BU Handling Technology

1) Application of CE symbol in accordance with EC Low Voltage Directive 2006/95/EC:  
 RC-10 1998; RC-J 2000; DRC-10 2004; DRC-J 2004; DRC MP 2005; DRC-DR 2005; DRC-DC 2006.

# = Modifications compared  
to previous issue

Normung DCC

Class. no.  
715 IS 975

22927149.indd271108

*Is this page relevant for the  
North American market?  
Can it be deleted?*



**FACILITIES ENGINEERING**

900 E. Orangefair Lane  
 Anaheim, California 92801  
 (714)447-0893 (800)344-7520  
 FAX (714)447-1443

**RECOMMENDED SPARE PARTS LIST**

BP Refinery Maintenance Shop  
 2350 East 223<sup>rd</sup> Street  
 Carson, CA 90810

Delivered: April 2012  
 Crane Serial No. L11135 & L11136

Component Description		Part Number	Qty
<b>BRAKE LININGS</b>			
Hoist Motor Brake Size B280	Brake wear & tear set	260 519 33	1
Hoist Motor Brake Size B280	Brake overhaul set	260 986 33	1
Trolley Motor Brake Size B020	Brake overhaul set	260 972 33	1
Trolley Motor Brake Size B020	Brake wear & tear set	260 975 33	1
Bridge Motor Brake Size B020	Brake overhaul set	260 972 33	2
Bridge Motor Brake Size B020	Brake wear & tear set	260 975 33	2
<b>HOIST REEVING</b>			
Wire Rope Set DR20 H24	4/1 18mm Dia.	707 911 33	1
Rope Guide		706 802 33	1
Grease DG 67 for Rope Guide		001 058 44	2
<b>FUSES</b>			
Main Fuse – Hoist	100 A Type J	002 039 49	3
Control Transformer Primary	2 A Type CC	132 301 49	2
Control Transformer Secondary	10 A Type CC	131 700 49	2
CAN Bus Fuse Protection(F1,F2)	0.25 A Type GMA	132 477 49	2
Bridge Inverter	50 A Type J	002 034 49	3
Trolley Inverter	20 A Type CC	132 303 49	3
Hoist Inverter	80 A Type J	002 037 49	3
Hoist Brake Control Circuit	2 A Type CC	132 301 49	3
Circuit Breaker, Cranelights	GV2-LE10, 6.3 AMP	575 055 44	1
<b>CONTACTORS</b>			
Main Contactor Hoist	TeSys LC1-D9522E7	719 616 33	1
Main Contactor Bridge	TeSys LC1-D5022E7	575 279 44	1
Main Contactor Control Relay	TeSys CA2-SK20E7	792 829 44	1
Cranelight Contactor	TeSys LC1-D32E7	719 892 33	1
Cranelight Time Delay	Omron H3DE-M2	132 110 49	1

---

**MISC. ELECTIRCAL**

Transformer	STR400,400 VA 230-500V/48V	730 151 45	1
Trolley Inverter	DeDrive DIC-4-014 C, 5.5 kW	719 806 33	1
Trolley Resistor	PWR R600 68 ohm	730 568 33	1
Bridge Main Line Filter	FN 3258-55-34, 55A	537 891 84	1
Bridge Inverter	DeDrive DIC-4-045-C, 22kW	730 560 33	1
Bridge Resistor	RHK, 15 ohm, 10.5kW	730 751 45	1
Hoist Inverter	DeDrive DIC-4-075, 37kw	730 562 33	1
Hoist Inverter CAN Comm Module	CM-CAN	537 726 84	1
Hoist inverter Line Reactor	3AC500V 75A, DK922/ 80	537 194 84	1
Hoist Resistor Overload Relay	3RU11 36-4GB1 36-45A	537 254 84	1
Hoist Braking Resistor	3xRHK8 44R, 44 ohm, 9.6 KW	719 890 33	1
Hoist Motor Pulse Generator	AG3, 1024 PPR	204 443 84	1
Geared Limit Switch	SGG 4NC, IP 65	719 994 33	1
Controller Card, Basic Module	Bridge, Brake LS-10 Cir.brkr.	719 388 33	1
Controller Card, Basic Module	Bridge	719 482 33	1
Controller Card, Basic Module	Hoist/Trolley DR20	719 462 33	1
Control Card, Frequency Inverter	HUB Inverter Card, FI	719 470 33	1
Pendant Controller	DSE10-R-VVV w/2TY Cable; 14 m	773 628 44	1
MS Overload	DR20 6/1 Set (32.0t) 2m/M5	730 583 33	1
Filter Fan, Hoist Encl. Lower	Pfannenberg 11622804050	008 774 49	1
Filter Fan, Hoist Encl. Upper	Pfannenberg 11622804053	008 775 49	1
Filter Thermostat	KTS 011, 10A, 1NO	730 524 33	1
Cranelight Bulb	400 W Mercury Vapor	004 612 49	1
Cranelight Ballast	Advance 78E6040-001	008 354 49	1
Radio transmitter	Demag DRC10-D2	772 563 44	1

---

**DEMAG Tools**

Metric Tool Kit		472 988 44	1
-----------------	--	------------	---

---

**MOTORS\***

Hoist Motor	ZBR180A4	008 676 49	1
Trolley Motor	ZBA90B 4I		1
Bridge Motor	ZBA100B4I		1

---

\* Motors are not considered typical recommended spare parts. However, down time for critical equipment may warrant their purchase

---