

Operating Instructions

Demag Cranes with Demag DR Rope Hoist

2023年12月31日

Manufacturer

Demag Cranes & Components Corp
29201 Aurora Road
Cleveland, OH 44139-1895
Telephone: (440) 248-2400 Fax: (440) 248-3086
Internet: <http://www.demag-us.com>

Contents

0	Foreword	5
0.1	Copyright	5
0.2	Customer Service	5
0.3	Liability for Defects	6
0.4	Limitations of Liability	6
0.5	Definitions	7
1	Safety Instructions	8
1.1	Symbol Description	8
1.2	Appropriate Use	8
1.3	Inappropriate Use	10
1.4	Basic Information on Safety	10
1.5	Selection and Qualification of Operating and Maintenance Personnel	11
1.6	Safety Instructions for Assembly and Disassembly	12
1.7	Safety Instructions when First Putting the Unit Into Service after Completing Assembly	12
1.8	Safety Instructions for Operation	12
1.9	Safety Instructions for Maintenance	13
1.10	Prescribed Crane Safety Features	15
1.10.1	Additional Safety Features which may be Present Depending on Operating Criteria (Examples)	15
2	Operation	16
2.1	Prevention of Accidents	16
2.2	Obligations of the Operator	17
2.2.1	Control Devices	17
2.2.2	Cable-Connected Floor Control – Remote Control	17
2.2.3	Attaching Loads	18
2.2.4	Observing the Loads	18
2.2.5	Bumper	18
2.2.6	End of Work	18
3	Taking the Crane Out of Service	19
3.1	Emergency-Stop Button	19
3.2	Taking the Crane Out of Service on Finishing Work	19
3.3	Taking the Crane Out of Service for Maintenance and Repair Purposes	19
4	Weather Influence and Dirt Accumulation	20
4.1	General	20
4.2	Cranes Sometimes Operating Outdoors	20
4.3	Cranes Operating Outdoors	20
4.4	Influence of Weather and Dirt on Runways	20
5	Maintenance	21
5.1	Inspection Before Operation	22
5.2	Inspection and Maintenance Schedule	23
5.3	Hoist Trolley	24
5.4	Crane bridge	24
5.5	Tightening Torque Requirements	24
5.6	Control	25
5.7	Power Supply	26

6	Manufacturer, Service and Spare Parts Contact Information	27
6.1	Manufacturer / Customer Service	27
6.2	Spare Parts	27
6.3	Service	27
7	Disassembly and Disposal	28
7.1	Disassembly	28
7.2	Disposal	28
8	Sound Pressure Level of Cranes	29
9	Electromagnetic Compatibility	31
10	Crane Inspections	32
10.1	Inspection Regulations	32
10.2	Crane Inspections	32
10.2.1	Frequent Inspection	32
10.2.2	Periodic Inspection	32
10.2.3	Initial Inspection and Load Test for Which the Owner is Responsible	33
11	Technical Description	34
11.1	Crane Types and Subassemblies	34
11.2	General	36
11.3	Main Subassemblies	36
11.3.1	Crane Girder	36
11.3.2	Monorail Hoist	36
11.3.3	Double-Rail Trolley	36
11.3.4	Crane Travel Unit	36
11.4	Crane Control System	37
12	Erection and Assembly	38
12.1	Delivery	38
12.2	Crane Runway Tolerances	38
12.3	Assembling the Crane when Supplied as Subassemblies	39
12.4	Bolted Connections	40
12.4.1	DFW-L-E, DFW-L-Z and DFW-L-T with Side Connection	40
12.4.2	KTD-E	41
12.5	Tightening Torques	43
12.5.1	Standard Bolted Connections	43
12.5.2	High-Tensile Bolted Connections	44
12.5.3	Verbus Ripp / Durlock Bolted Connections	44
12.6	Example for Installing the Crane on the Runway	45
12.6.1	Single-Girder Crane	45
12.6.2	Double-Girder Crane	45
13	Putting into Service for the First Time Following Assembly on site	46
13.1	Notes and Inspections	46
14	Sample Checklist	47

0 Foreword



You have purchased a Demag crane. This crane has been built in accordance with German and European standards and regulations. The crane complies with the statutory regulations e.g. EC directive 98/37/EC.

Demag cranes are of modular design. The main assemblies include:

- Crane bridge
 - Crane girder
 - Travel units
 - Motors
 - Gearbox
- Trolley
 - Load handling attachments
 - Hoist unit
 - Travel units
 - Motors
 - Gearbox
- Electrical equipment
 - Power supply
 - Regulating devices
 - Control devices
 - Control pendant
 - Ground-level station

These operating instructions are designed to provide the owner with appropriate instructions for safe and correct operation and to facilitate maintenance.

Every individual given the task of transporting, installing, commissioning, operating, maintaining and repairing our cranes and their additional equipment must have read and understood

- the operating instructions,
- the safety regulations and
- safety instructions in the individual chapters and sections.

The operating instructions must be available to the operating personnel at all times in order to prevent operating errors and to ensure smooth and trouble-free operation of the cranes.

0.1 Copyright

These operating instructions must be treated confidentially. They should only be used by authorized personnel. They may only be entrusted or made available to third parties with the prior written consent of Demag. All documents are protected within the sense of copyright law.

No part of this documentation may be reproduced, utilized or transmitted without specific prior consent.

Infringements are an offence resulting in obligatory compensatory damages. All industrial rights reserved.

0.2 Customer Service

The aftersales package will provide you with all technical information for proper maintenance and proper inspection for Demag products.

Should you have any questions regarding our products, please refer to one of our authorized service providers, the relevant Demag representative, or to our main office.

Please state the pertinent serial number, order number, and model designation (see test and inspection booklet, crane capacity plate) in any correspondence or for spare part orders. Specifying this data ensures that you receive the correct information or the required spare parts. The telephone number of our head office is given on page 3.

0.3 Liability for Defects

These operating instructions must be read carefully before installing and putting the crane into operation.

We assume no liability for damage and malfunctions resulting from failure to comply with the operating instructions and/or improper service.

Claims of liability for defects must be made by quoting the order number and serial number immediately on detecting the defect.

Any liability claims for defects are void in the event of:

- inappropriate use, overloading beyond rated capacity, side pulling of the load, excessive jogging, damage to pushbuttons and operator control interfaces from impact, environmental exposure not specified in original order, lack of maintenance, lack of lubrication or use of improper lubricants.
- faulty devices or equipment connected or attached to the product which are not part of our scope of supplies and services,
- use of non-genuine spare parts and accessories,
- refurbishment or modification of the product unless approved in writing by Demag.
- improper service or improper maintenance.

0.4 Limitations of Liability

Wearing parts are not subject to liability for defects.

- Normal wear of any part is not covered by warranty.
- Brake linings, wire ropes, rope guides, and sheaves are excluded from warranty coverage.

All technical information, data and instructions for operation contained in these operating instructions were up-to-date on going to print and are compiled on the basis of our experience and to the best of our knowledge.

We reserve the right to incorporate technical modifications within the scope of further development of the cranes which are the subject of these operating instructions.

The information, illustrations and descriptions contained in these operating instructions are therefore only intended for information purposes.

The descriptions and illustrations contained in this documentation do not necessarily correspond to the scope of delivery or any subsequent spare part delivery, either; the drawings and illustrations are not to scale.

Only documentation belonging to the actual order is valid.

We assume no liability for damage and malfunctions caused as a result of operating errors, non-compliance with these operating instructions or inappropriate repairs and maintenance.

We expressly point out that only genuine Demag spare parts and accessories approved by us may be used. Accordingly, this also applies to other manufacturers' parts supplied by us.

For safety reasons, the fitting and use of spare parts or accessories which have not been approved and unauthorized modification and conversion of the product are not permitted and exempt Demag from any liability for damages resulting therefrom.

With the exclusion of any further claims, our liability for defects and liability obligations for any defects pertaining to the products supplied or faults in the documentation delivered or any negligence on our part are exclusively based on the stipulations of the original contract. Any further claims, in particular any and all claims for damages, are excluded with the exception of legal claims in accordance with product liability legislation.

0.5 Definitions

Owner

Owners (employer, company) are defined as persons who own the crane and who use it appropriately or allow it to be operated by suitable persons.

Operating personnel/operator

Operating personnel or operators are defined as persons entrusted by the owner of the crane with operation of the crane.

Specialist personnel

Specialist personnel are defined as persons assigned by the owner to carry out special tasks such as installation, setting-up, maintenance and fault elimination.

Qualified electrician

Qualified electricians are defined as persons who, owing to their technical training, knowledge and experience of electrical installations as well as knowledge of the relevant standards, codes of practice and regulations, are able to assess the tasks given to them and to identify and eliminate potential hazards.

Trained person

Trained persons are defined as persons who have been instructed and trained for the tasks assigned to them and on the possible hazards resulting from incorrect handling and who have been informed about the required protective devices, protective measures, relevant regulations, codes of practice, accident prevention regulations and operating conditions and who have proven their qualifications.

Experienced technician

Experienced technicians are defined as persons, who, owing to their technical training and experience, have sufficient knowledge of cranes and are familiar with the relevant national industrial safety regulations, codes of practice, accident prevention regulations, directives and generally accepted engineering standards enabling them to judge the safe operating condition of cranes.

Cranes

Cranes are systems used for lifting, lowering and moving loads. This definition also applies to rail-mounted lifting equipment.

1 Safety Instructions

1.1 Symbol Description

The following symbols and recommendations indicate potential safety hazards or causes of damage or provide useful information.



Safety at work symbol

This symbol appears in the operating instructions next to all instructions relating to safety at work wherever a potential hazard to life and limb exists.

Follow these instructions at all times and be particularly vigilant and cautious.

Pass on safety instructions to all persons entrusted with working on the crane, the runway and the power supply system.

In addition to the safety instructions, observe all general safety regulations and accident prevention regulations at all times.



Warning against electrical hazards

Contact with live parts can result in immediate death. Protective covers (e.g. covers and enclosures) marked with this sign may only be opened by qualified electricians. Before opening, all relevant operating, control, feed or other voltages must be disconnected.



Warning against suspended load

Any person remaining in this danger zone may suffer serious injury or death. This applies in particular to non-positive locked load handling attachments e.g. magnet and vacuum systems. In each case the special safety and operating instructions contained in the operating instructions for the load handling attachment in question must be complied with.



Operating hazard for the installation

This symbol indicates information on the appropriate use of machinery. In the operating instructions, it indicates all warnings which, if not complied with, may result in damage to the crane or the load.

1.2 Appropriate Use

Cranes are only intended for lifting, lowering and moving loads and may be used both as stationary or travelling units.

Cranes may only be operated when in perfect working order by trained operating personnel in accordance with the relevant safety and accident prevention regulations and codes of practice. This also includes compliance with the operating and maintenance conditions specified in the operating instructions. It is assumed that the line voltage and frequency at the power feed to the crane is within the permissible tolerances according to DIN IEC 60038.



Cranes are industrial equipment operated with a rated voltage of up to 1000 V from high-voltage supply systems. Any use exceeding the scope of the operating conditions specified in the operating instructions and/or agreed in the contract between manufacturer and owner is not permitted.

Power feed is via a power supply system (mobile cables, open or enclosed conductor systems, cable drums). These systems are live up to the terminals of the main switches (mains connection switch, isolating switch) on the cranes (see Fig. 411 270 44). The relevant main switches must be switched off and secured when maintenance/repair work is carried out.

During operation or when the main switch is not switched off, electrical components inside enclosures, motors, switchgear cabinets, load handling attachments, terminal boxes, etc., carry dangerous voltages. This voltage may cause fatal injuries.

Serious personal injury or damage to property may occur in the event of:

- unauthorized removal of covers,
- inappropriate use of the crane,
- incorrect operation
- insufficient maintenance,

- exceeding the maximum permitted load
(The rated load capacity/S.W.L. is the maximum permitted load. Pay attention to the sum of the load to be lifted and the load handling attachment.)
- Working on live parts.



After actuating an Emergency Off switch or an Emergency-Stop button in the event of danger, such switches/buttons must not be reset until the cause of the dangerous situation has been eliminated.

Example

Crane power feed
Switch and main switch arrangement
(single-pole arrangement shown)

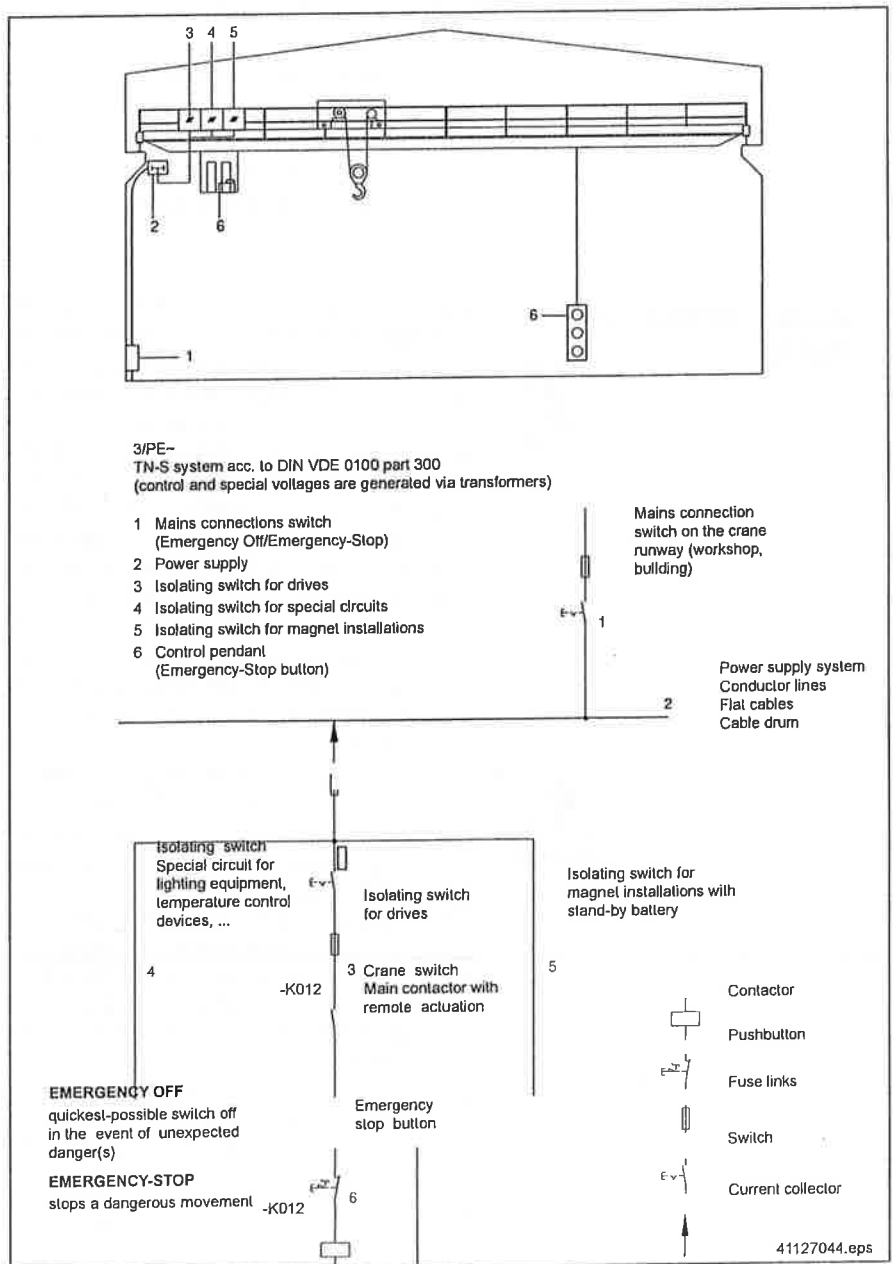

1.3 Inappropriate Use



Certain work and practices are prohibited when using the crane as they may involve danger to life and limb and result in lasting damage to the crane, e.g.:

- Unsafe load handling (e.g. swinging the load).
- Handling suspended loads above persons.
- Pulling or dragging suspended loads at an angle.
- Pulling free fixed or obstructed loads.
- Exceeding the maximum permitted load and permitted load dimensions.
- Leaving suspended loads unsupervised.
- Running load-supporting means (chains and ropes) over edges.
- Using load-supporting means (chains and ropes) as a load bearing sling.
- Subjecting the control pendant to inappropriate mechanical loads
- Allowing loads to drop when the load-supporting means are in a slack condition.
- Failing to pick up loads from a solid base, but, for example, from a load handling attachment.
- Transporting persons, unless lifting devices are specifically approved for transporting persons.
- Lifting the load when the rope is in slack condition.
- Lifting the load at full speed.
- Manipulating electrical equipment.

1.4 Basic Information on Safety



Persons under the influence of drugs, alcohol or medicines which affect reactions must not install, operate, put into service, maintain or repair cranes.

Any conversions and modifications to the installation must comply with the technical safety requirements. Work on electrical equipment of cranes may only be carried out by qualified electricians in accordance with electrical regulations. In the event of malfunctions, crane operation must be stopped, switched off and the relevant main switches locked immediately. Malfunctions must be eliminated immediately. The crane may not be put into operation again until the cause of the defect has been rectified.

National accident prevention regulations and codes of practice and general safety regulations must be observed when operating cranes. Important information and instructions are marked by corresponding symbols. Follow these instructions and/or safety regulations in order to avoid accidents and damage.

The operating instructions must be kept available at the place where the crane is in use at all times. They include significant aspects and appropriate excerpts from the relevant guidelines, standards and regulations. The owner must instruct his personnel appropriately.

Any failure to comply with the safety instructions stated in these operating instructions can result in death or personal injury.

Observe general statutory and other obligatory regulations relating to accident prevention and environmental protection and basic health and safety requirements in addition to those included in these operating instructions. Such requirements may relate, for example, to the handling of hazardous materials or the provision/wearing of personal protection equipment. Comply with these regulations and general accident prevention regulations relevant for the place at which the crane is used and follow the instructions therein when working with the equipment. The crane may still constitute a danger to life and limb if it is installed, operated, maintained or used improperly by personnel which have not been trained or specially instructed.

The operating instructions must, if required, be supplemented by the owner with instructions and information (e.g. factory regulations) relating to organization of work, working procedures, operating personnel, etc. Supervising and reporting obligations as well as special operating conditions must also be taken into consideration. Supervising and reporting obligations as well as special operating conditions must also be taken into consideration.

Personnel assigned to working with the crane must have read and understood the operating instructions and, in particular, the chapter on Safety Information. All activities relating to cranes which are not described in these operating instructions may only be carried out by specialist personnel specifically trained for the particular crane.

The owner must ensure that personnel work in a safety and hazard-conscious manner in compliance with the operating instructions. The owner must ensure that the cranes are only operated when in proper working order and that all relevant safety requirements and regulations are complied with.

Cranes must be taken out of service immediately if functional defects or irregularities are detected. In the event of a stoppage (e.g. if defects regarding safe and reliable operation are detected, in emergency situations, in the event of operating malfunctions, for repairs and maintenance purposes, if damage is detected or after finishing work), the operator/experienced technician must carry out all prescribed safety measures (e.g. for cranes operating outdoors, ensure wind drift safety catch is fitted) or observe that they are automatically carried out.

Personal protective clothing must be worn as necessary or as required by regulations. Personnel must not wear loose clothing, jewelry including rings or long hair loose. Injury may occur, for example, by being caught or drawn into the mechanism.

All safety and hazard information and recommendations on the crane, e.g. at access points and mains connection switches must be maintained in complete and legible condition. Inching must always be avoided. Emergency limit stop devices (e.g. slipping clutch or emergency limit switch) must not be approached in normal operation.

Modifications, additions to and conversions of the crane which may impair safety in any way must not be carried out without the written approval of Demag. This also applies to the installation and adjustment of safety devices as well as for performing welds on load bearing parts. Safety devices must not be rendered inoperative. Only genuine Demag spare parts and accessories may be used. Observe prescribed deadlines or those specified in the operating instructions for routine checks/inspections.

1.5 Selection and Qualification of Operating and Maintenance Personnel



For independent operation or maintenance of the crane, the owner may only employ persons:

- who are mentally and physically suitable,
- who have been instructed in the operation and maintenance of the crane and have proven their qualification to the owner in this respect (in addition to theoretical training, instruction also includes sufficient practical operating experience as well as acquiring the ability to identify defects which are a hazard to safe operation),
- who can be expected to carry out the work assigned to them reliably.

The owner must assign operating and maintenance personnel to their relevant tasks.

In general practice, no person should be permitted to operate a crane:

- (a) Who cannot speak the appropriate language or read and understand the printed instructions;
- (b) Who is not of legal age to operate this type of equipment;
- (c) Whose hearing or eyesight is impaired (unless suitably corrected - with good depth perception);
- (d) Who may be suffering from heart or other ailments which might interfere with the operator's safe performance;
- (e) Unless the operator has carefully read and studied the operation manual supplied by the Crane Manufacturer;
- (f) Unless the operator has been properly instructed;
- (g) Unless the operator has demonstrated his instructions through practical operation;
- (h) Unless the operator is familiar with hitching equipment and safe rigging practices.

1.6 Safety Instructions for Assembly and Disassembly



- Installation and disassembly work may only be performed by experienced technicians per CMAA #78 Standards and Guidelines for Professional Services Performed on Overhead and Travelling Cranes and Associated Hoisting Equipment.
- Installation and disassembly work must be co-ordinated by the person carrying out the work and the owner within the scope of their responsibility.
- The danger zone must be made safe.
- The installation must be isolated in accordance with the relevant electrical regulations.
- Customer-specific regulations must be observed.
- Only appropriate, tested and calibrated tools and equipment may be used.
- The electrode holder and earth must be connected to the same assembly when welding work is carried out. If the current flow is returned via protective conductors, screening elements or anti-friction bearings, serious damage may be caused to these or other components.
- Installation and disassembly work must be prepared and carried out so that crushing and shearing hazards are excluded.

1.7 Safety Instructions when First Putting the Unit into Service after Completing Assembly



- The working and danger area must be made safe.
- First check that the voltage and frequency specified on the data plates match the owner's mains power supply
- All clearance dimensions and safety distances (see approval drawing) must be checked before putting the unit into service.
- When putting the unit into service, it may be necessary to perform work in the danger zone.
- In the course of putting the product into service, it may be necessary to render safety devices or features inoperative when carrying out adjustments or function checks.
- It must be ensured that only trained personnel are employed for putting the unit into service.
- To compensate any settling, all bolted connections must be tightened one to two months after first putting the crane into service.

1.8 Safety Instructions for Operation



The operator must check the function of the brakes and emergency limit stop devices before starting work.

All instructions and measures concerning general safety and accident prevention which have to be observed before, during and after putting into service must be strictly complied with. Any failure to comply can lead to accidents resulting in fatalities.

Cranes must be taken out of service immediately or not put into operation if any defects relating to operating safety and reliability are detected. Safety devices must not be rendered inoperative or modified in contradiction to their intended use.

Only operate cranes when all protective devices and safety-relevant equipment, e.g. movable protective devices and Emergency-Stop devices, are fitted and fully functioning.

Anybody who identifies an immediate danger of personal injury must actuate the Emergency Stop button without delay. This also applies in the case of damage occurring to parts of the installation and equipment which makes immediate stoppage necessary.

After an "Emergency Off or an Emergency-Stop", the operator must not switch on and restart the crane until an experienced technician is satisfied that the cause which led to actuation of this function has been rectified and that continued operation of the installation constitutes no further hazard.



Cranes must be switched off immediately in the event of the following faults:

- In the event of damage to electrical devices and cables as well as parts of the insulation.
- In the event of brake and safety device failure.
- In the event of damage to:
 - lifting ropes
 - lifting chains
 - load hook
 - load handling attachments
 - any other load-bearing parts



If the lifting movement is switched off while the load is being lifted, this may indicate response by the load detector. In this case a load already lifted must be deposited immediately.

Before switching on/putting into operation of the crane it must be ensured that nobody is endangered by operation of the crane.



If the operator notices persons who may be exposed to a risk to health or personal safety by operation of the equipment, he must suspend operation immediately and may not resume operation again until the persons are outside the danger zone.

Before putting the crane into operation, the operator must be satisfied that the installation is in safe and correct operating condition.



Work on cranes may only be carried out when instructions to this effect have been issued, when operation and function of the crane have been explained and when the working and danger zone has been made safe. Cooling devices, such as ventilation openings, may not be rendered permanently inoperative (e.g. covered or closed).

Special local conditions or special applications can lead to situations which were not known when this chapter was written. In such cases, special safety measures must be implemented by the owner.

1.9 Safety Instructions for Maintenance

Maintenance measures are defined as regular maintenance, inspection and repair work.

Mechanical and electrical repairs and maintenance work may only be carried out by appropriately trained personnel (experienced technicians) per CMAA #78.

Adjustment, maintenance and inspection activities and inspection deadlines including specifications concerning replacement of parts/assemblies prescribed in the operating instructions must be observed.



Ensure that all electrical components are de-energized before commencing work on electrical installations and devices. When all work on the crane has been completed, operation of the crane must not resume until the owner has given approval to this effect.

Unauthorized persons must be prohibited from carrying out work on machinery or parts of the crane. Before starting all maintenance work, the crane must be switched off and taken out of service and secured against accidental or unauthorized putting into operation (restarting). Switches must be locked.



It must be ensured that:

- the crane is switched off and checked that it is de-energized and, in special cases, isolated,
- moving parts are stationary and stopped,
- moving parts cannot start moving while maintenance work is being carried out,
- the power supply cannot be accidentally restored as long as the crane has been taken out of service for maintenance and repair purposes
- Ensure that operating and auxiliary materials as well as spare parts are disposed of in a safe and environmentally sound way.

Instructions for repair work in the course of operation

The danger zone must be marked off with red/white safety chains or safety tape and indicated with warning signs.

Mobile cranes, forklifts and other machinery are often required to complete the work. Each Employee has the responsibility for the safe operation and use of any such equipment prior to operation. Mobile cranes, forklifts, scissors lifts, boom lifts, and other machinery shall only be operated by trained, licensed (where required) individuals. Refer to manufacturer's requirements for specific operating procedures and requirements. All equipment shall be in good operating condition with all required inspection and maintenance documentation available.

Work areas should, wherever practical, be identified by highly visible signs, barriers or other appropriate means to alert others that overhead work is being performed.

All ladders shall be used in compliance with the manufacturer's recommendations. Care shall be taken to secure the ladder to prevent falling or slipping.

Service providers should have a Fall Protection Policy.

In each individual case, the owner or the person specified by him must check whether the relevant work may be carried out in the course of operation without risk of personal injury owing to the particular local conditions.

Use only calibrated and appropriate tools and auxiliary materials for maintenance and repair work.

If there is a risk of objects falling, the danger zone must be made safe.

Maintain a sufficient safety distance to moving or rotating parts to prevent clothing, parts of the body or hair becoming entangled.

Avoid naked flames, extreme heat and sparks in the vicinity of cleaning agents and flammable parts or parts liable to deformation (e.g. wood, plastic parts, oil, grease) in electrical installations – non-compliance may result in fire hazard. Harmful gases may evolve or insulation may be damaged.

Additional instructions for repair work on electrical equipment

Only genuine fuse links with specified amperage and tripping characteristics may be used.

Defective fuse links must not be repaired or bridged and must only be replaced by fuse links of the same type.

Switch off the crane immediately in the event of electrical power supply malfunctions.

Work on the electronic and electrical components or equipment may only be carried out by qualified electricians.

If inspection, maintenance and repair work is to be carried out on parts of the product, these must – if prescribed by regulations – be isolated. First verify the safe isolation of the parts from the supply before commencing work.

The electrical equipment of the crane must be inspected and checked at regular intervals. Defects, such as loose connections, damaged cables and worn contactor contacts must be rectified immediately.

Since it is possible that after a longer period of operation the switching points of relays (time, frequency and monitoring relays) change due to ageing of the components, the relay switching points in circuits relevant to safety must be checked at regular intervals.

Electrical equipment must be replaced as a preventive measure on reaching the limit of its theoretical duration of service (service life).

If work has to be carried out on live parts, a second person must be available in order to actuate the Emergency-Stop button or mains connection switch/isolating switch for voltage disconnection in an emergency.

The second person must be familiar with resuscitation measures.

Only use insulated tools.

Before disconnecting and connecting electrical plug-and-socket connections, always disconnect them from the supply (this does not apply to mains connections, provided they do not represent a dangerous contact voltage in the sense of the safety regulations).

Service providers should have a Lockout / Tagout policy. The purpose of this policy is to protect Employees against unexpected release of energy including electrical, pneumatic, hydraulic, chemical and other potential energy resources.

1.10 Prescribed Crane Safety Features

General

- Bumpers on the cranes and at the ends of the cross-travel rails designed according to DIN 15018
- Brake devices for all drives, active also in the event of driving gear standstill, Emergency-Stop, Emergency Off and power failure

Cranes with cable-connected control pendants

- For max. long and cross-travel speeds up to 175 ft/min
- Lockable mains connection switch (on the runway)
- Lockable isolating switch (on the crane)
- Remotely-controlled crane switch main contactor in conjunction with a lockable Emergency-Stop button
- Emergency limit switch for highest and lowest hook position
- Operating limit switch for highest and lowest hook position if the end positions are approached in normal operation (must be possible to check function of the emergency limit switch)
- Long and cross-travel limit switches if the limits of travel are approached in normal operation.

1.10.1 Additional Safety Features which may be Present Depending on Operating Criteria (Examples)

Additional requirements for cranes with remote control

- Recommended long and cross-travel speeds less than or equal to 320 ft/min (higher speeds are possible)
- Long and cross-travel limit switches to switch off fast travel speeds before limits of travel are reached

2 Operation

2.1 Prevention of Accidents



Observe relevant national safety regulations and codes of practice when operating and maintaining the crane. (Ref. OSHA 1910.179, ASME B30.2, ASME B30.11, ASME B30.16, ASME B30.17, and CMAA Crane Operator's Manual)

In the interests of safety, therefore, it is essential that these regulations and codes of practice are explained carefully to all persons assigned to operating/maintaining cranes.

The safety regulations and codes of practice must be available to the operator at all times.

2.2 Obligations of the Operator

Observe the following instructions and recommendations:

- The operator must check the function of the brakes and emergency limit stop devices – with the exception of slipping clutches – before starting work.
- The operator must visually inspect the crane for obvious defects, proper function, deterioration, wear, and rope reeving.
- The operator must pay attention to the assignment of the control device and crane in the case of remotely controlled cranes.
- The operator must inform the safety officer/supervisor responsible and his successor when crane operators are changed about all defects, damage and malfunction.
- The operator must stop operation of the crane immediately if any defects which prejudice safety or endanger the crane/crane equipment are detected.
- Control devices must only be actuated from the cab/control position.
- The crane must not be parked above or below sources of heat.
- Do not exceed capacity.
- Maintain firm footing while operating.
- Rope free of kinks and not wrapped around load.
- Attach load only with slings or lift devices.
- Slings clear any obstacles.
- No kinks in rope.
- No twisted lines.
- Hook not swinging.
- No sudden speed changes.
- No travel with someone on the load.
- Test hoist brakes close to ground.
- Check hoist limit switch at beginning of every shift as a minimum
- Be familiar with hand signals
- Make sure no one is on the crane.
- Make sure controls are off when turning on at E-Stop switch.
- If power fails during operation, engage E-Stop.
- Be familiar with equipment so problems can be recognized and reported.
- Contact other cranes and stops with extreme caution.
- Hook brought over load without swinging.
- No contact with obstacles.
- Avoid side pulls.
- Avoid moving loads over people.
- Test hoist holding brakes close to floor for all heavy loads.
- Do not leave a suspended load unattended.
- Do not use upper limit as an operating control
- Inspect wire rope visually.
- Do not attempt to lengthen the wire rope or repair a damaged wire rope.
- Inspect hook.
- Inspect hook latch.

- Report missing or illegible labels.
- Do not operate if tagged out of order.
- Be familiar with operation.
- Be familiar with equipment.
- Center crane hook over load.
- Verify slings or lift devices are in bowl of hook.
- Verify latch is not supporting load.
- Verify hook tip is not supporting load.
- Verify load is balanced.
- Verify rope is in drum grooves.
- Do not divert attention.
- Do not lift until personnel and self are clear of load.
- Ensure load is free to move.
- Remove rope slack slowly.
- Ensure load will clear all obstacles.
- Avoid reversing direction quickly.
- Avoid swinging load.
- Avoid running trolley into stops.
- Avoid running crane into stops.
- Leave at least 2 wraps of rope on drum.
- Activate warning device when starting movement or approaching people.
- Verbally warn people when there is no warning device.
- Do not lower until area is clear.
- Block loads if slings are to be removed.
- Exercise care when removing slings.
- Position hook above head level for storage.
- Obey all stop signals.
- Do not adjust or perform maintenance unless qualified.
- Do not use crane as a limiting device to measure load weight.
- Do not allow a welding electrode to be touched to the wire rope.
- Do not perform or allow anyone to perform any work on a suspended load that requires a worker to be positioned under a suspended load.
- Exercise common sense.

2.2.1 Control Devices



Switch the crane on by unlatching the Emergency-Stop button (crane switch actuation).

The crane operator must ensure that:

- all control devices are in zero position before enabling the energy supply to the drives,
- the control devices are in zero position and the energy supply is disabled before leaving the cab/control position,
- the remote control unit is secured against unauthorized operation (switching-on) before putting the unit down.

2.2.2 Control Pendant Cable-Connected Floor Control – Remote Control

The operator selects the lifting and travel motions, and if necessary the functions of the additional facilities, by means of the control unit. The control unit must be treated with care. Recharge the rechargeable batteries of remote control units in good time.

2.2.3 Attaching Loads

Heavier loads than those specified on the safe working load plate must not be picked up.

The deadweight of load handling attachments which are not a permanently connected integral part of the crane is part of the payload. When attaching the load, ensure that loads are picked up in such a way that they cannot accidentally fall over, fall apart, slide or roll away. In this context, refer to the relevant regulations and codes of practice pertaining to the application and loading of chain and rope slings.

The operator must not move loads attached by hand until he has received a clear sign from the person attaching the load, the marshaller or another responsible person appointed by the owner.

If signals have to be used for communication with the operator, they must be agreed between the person responsible and the operator.

The operator must not handle loads if he recognizes that they are not appropriately attached. The operator must keep the control unit within hand's reach as long as a load is suspended from the crane.

End positions which are limited by emergency limit stop devices or slipping clutches only must not be approached in normal operation.

If the hoist operating limit switches fail and the emergency limit switches are approached, the hoisting or lowering motion and the crane switch main contactor are switched off (double-circuit system).

A load already lifted can then only be deposited by additionally pressing the "Emergency limit switch check" function unit in the control device.

The fault must be eliminated before starting up the crane again.

Press the Emergency-Stop button immediately if the lowering speed is too high (falling load), which may occur in the case of malfunctions. Stop crane operation until the fault is completely eliminated. If possible without danger, safely deposit loads beforehand.

The operator must guide push-travel and semi-driven cranes in such a way that he can bring motions to a stop without danger.

2.2.4 Observing the Loads

The operator must observe the load or, in the case of no load, the load handling attachments during all crane movements. If it is not possible to observe the load or the load handling attachments, the operator may only control the crane in accordance with the signs given by a marshaller. This does not apply for program-controlled cranes. The operator must give warning signs as required. Do not handle suspended loads above persons. He must not transport loads above persons when using load handling attachments which retain the load by means of magnet, friction or suction forces without an additional load securing device.

2.2.5 Bumper

The crane and trolley hoist are fitted with elastic bumpers to limit the forces transmitted by the crane and/or trolley hoist when approaching the bridge or cross-travel limit stops and/or adjacent cranes/trolleys/hoists.

Adjacent cranes and trolleys are also fitted with appropriate elastic bumpers. The condition of bumpers must be inspected regularly (cracks and lasting deformation indicate that they no longer function correctly).

2.2.6 End of Work

Move the crane to the predetermined parking position on finishing work.

Set down and switch off load handling attachments such as grabs or magnets.

Finally, switch the crane off and engage the wind drift safety devices, if fitted (see also the "Taking the crane out of service when finishing work" section).

3 Taking the Crane Out of Service

3.1 Emergency-Stop Button



It must be possible to interrupt the electrical power supply to all drive units from the operating position. This is done by actuating the Emergency-Stop button in conjunction with the crane switch (load switch), with the exception of facilities such as e.g. magnet systems.

3.2 Taking the Crane Out of Service on Finishing Work



At the end of work, the operating personnel must interrupt the power supply to the crane. The installation is disconnected from the mains by switching off the mains connection switch or the isolating switch.

Cranes which are periodically exposed to the wind must be parked in the building on finishing work.

Cranes operating exclusively outdoors are equipped with wind drift safety devices which must be engaged during longer crane downtimes and on finishing work. See also chapter "Weather Influence and Dirt Accumulation".

3.3 Taking the Crane Out of Service for Maintenance and Repair Purposes



The mains connection and/or isolating switches (when two or more cranes operate on the same runway) must be switched off and secured against accidental and unauthorized restoration of the power supply when maintenance and repair work is performed. Also refer to the "Safety Instructions" chapter.

Engage the wind drift safety device on cranes which are exposed to the wind.

Following completion of maintenance and repair work, operation of the installation must not resume until the owner has given approval to this effect.

4 Weather Influence and Dirt Accumulation

4.1 General

Our cranes are intended for use in the following operating conditions:

- 14° to 104° F (-10° to 40° C) ambient temperature
- Air humidity up to 80%
- Installation height up to 3300 ft (1000 m) above sea level

Other operating conditions are possible after clarification of the measures required to be taken.

Crane operation must be stopped if safe crane operation (controlled handling of crane, load handling attachments and load) can no longer be guaranteed due to adverse weather conditions.



First deposit loads safely.

During thunderstorms it is forbidden to walk on crane runway(s) and crane(s). It is also forbidden to leave the cab, if any.

4.2 Cranes Sometimes Operating Outdoors

A wind drift safety device is not necessary for cranes operating mostly indoors and only some of the time outdoors.

When a storm or strong winds are approaching, the operator must move the crane into shelter in the building in good time.

4.3 Cranes Operating Outdoors

Cranes operating all or most of the time outdoors are equipped with wind drift safety devices.

The wind drift safety devices must be engaged during longer crane downtimes and when strong winds or storms are approaching.

Cranes operating outdoors should be kept under shelter when not in operation.

4.4 Influence of Weather and Dirt on Runways

For safety reasons all runways must be kept clear of oil, grease and/or dirt, as such contamination impairs the start-up and braking of cranes and trolleys.

For the same reason all runways must also, if necessary, be cleared of ice and snow before starting operation.

Check the function of current collectors and the power supply before starting up and, if necessary, de-ice them in a disconnected state.

Viscous oil (e.g. in gear units) impair or prevent crane or trolley start-up. De-ice frozen brakes on lifting and travelling gears before starting work or, if necessary, after long downtimes and apply the brakes "warm".

Precautionary measures to ensure safe crane operation are the responsibility of the owner.

5 Maintenance

Preventive Maintenance shall be performed based, as a minimum, on the crane manufacturer's recommendations.

Maintenance procedures shall include, as a minimum, the following precautions:

The crane to be maintained shall be moved to a location where it will cause the least interference with other cranes and operations in the area.

All controllers shall be at the off position.

The main electrical disconnect switch shall be open and locked in the open position. Follow appropriate lockout/tagout procedures.

Warning or "out of order" signs shall be placed on the crane and shall also be placed on the floor beneath or on the hook so as to be visible from the floor.

Where other cranes are in operation on the same runway, rail stops or other suitable means shall be provided to prevent interference with the idle crane. Additionally, other crane operators on the same runway and in adjacent runways shall be notified of the out-of-service crane.

After adjustments, maintenance, or repairs have been made, the crane shall not be operated until all guards have been reinstalled, safety devices reactivated and maintenance equipment removed.

Adjustments, maintenance, or repairs to correct any unsafe conditions shall be disclosed by the inspection reports or by operating personnel before operation of the crane is resumed. Adjustments, maintenance, or repairs shall be done only by qualified personnel in accordance with CMAA #78.

Maintenance Records

Records shall be kept on file evidencing adjustments, maintenance, and repairs that have been performed. Maintenance records should be retained for the life of the equipment.

Maintenance records should document routine and preventive maintenance activities as well as adjustments, maintenance and repairs that result from inspections.

Safety Hazards

Safety Hazards shall be reported to the responsible person, in written format, immediately upon discovery. Reports should include specific identification of the hazard, and a recommendation(s) for remediation of the hazard.

Maintenance Issues

Maintenance issues shall be reported to the appropriate supervisor or responsible person, in written format, within a reasonable time from discovery. Damage, safety related issues and/or imminent equipment failure must be reported immediately. Reports should include specific identification of the item and a recommendation(s) for remediation of the item. Unsafe conditions disclosed by the inspection should be corrected before operation of the crane is resumed.

If required, our after-sales service will carry out inspection of your cranes. In this case, we recommend you conclude an inspection and maintenance agreement.

These operating instructions must be used to identify deviations/damage which could impair regular crane operation.

Observe the contents of the "Taking the crane out of service for maintenance and repair purposes" section in the "Taking the crane out of service" chapter when performing maintenance and repair work.

The specified inspection intervals apply to cranes in single-shift operation. Cranes which are used in multiple-shift operation or which are exposed to special ambient conditions in hardening shops, galvanizing facilities, casting shops, etc. require shorter inspection intervals.

The stress group and group of mechanisms classifications are documented in the crane test and inspection booklet.

The prescribed regular checks and inspections are not included in these operating instructions. These specifications are included in the operating instructions of the components fitted.



Maintenance work must only be performed by qualified personnel.

Training by the manufacturer is required for some maintenance activities and is available by contacting Demag.

The electrode holder and ground must be connected to the same assembly when welding work is carried out. If the current flow is returned via protective conductors, screening elements or anti-friction bearings, serious damage may be caused to these or other components.

Crane component assemblies to be inspected are listed as follows, e.g.

- Trolley/monorail hoist with hoist unit and travel units
- Crane bridge with travel units
- Control
- Regulating devices
- Control devices
- Control pendant
- Power supply
- Crane runway.

Other subassemblies, if fitted, are documented separately and must be checked.

To compensate any settling, all bolted connections must be tightened one to two months after first putting the crane into service.

5.1 Inspection Before Operation

The operator must carry out inspections in accordance with the following instructions before starting work. The crane must be taken out of service immediately if the crane operator detects any defects relating to operating safety and reliability.

Such defects include, for example:

- brake or emergency limit switch failure,
- damage to the rope,
- unusual noises in the gearbox, etc.

Visual checks before turning on power:

1. Look at the crane and major components for damage.
2. Look for tags or out-of-order signs, and do not attempt to operate if present.
3. Look for loose objects or parts on crane or under it.
4. Look for oil leakage on crane and floor due to crane.
5. Look at the drum for proper spooling of wire rope.
6. Look at the reeving of wire rope or load chain for proper pattern.
7. Look at the visible portion of the sheave grooves for imprinting onto surface.
8. Look at visible rope for damage, breaks, elongations, and/or kinks.
9. Look at the hook, safety latch, and other lifting devices for damage.
10. Look at the control cable for damage and check labels are present and legible.
11. Look at the pendant and pushbuttons for damage.
12. Make sure there is proper lighting.

Function tests before turning on power:

1. Make sure the E-Stop is in the power off position and depress the buttons on pendant for all crane motions to be sure E-Stop is working properly and that no pushbuttons are sticking.
2. Manipulate hook latch for proper function, and check for latch not hanging up.

Function check:

1. Set E-Stop to the power on position.
2. Activate and test all audible and visible warning devices.
3. Move hoist down and up at all speeds.
4. Move trolley left and right.
5. Move bridge forward and away.
NOTE: This procedure checks the brakes and movements should be smooth and stopping should be expedient.
6. EVERY SHIFT, raise the hoist to check the upper limit switch. Take care not to create a two-block condition if the limit fails. Move the hook slowly.
7. Listen for unusual sounds.

Brake test under load:

1. On first lift with load after checking above items, raise load above ground a few inches and hold. This tests the holding brake on the hoist.

Reporting deficiency found during inspection:

1. Report any deficiencies to supervisor immediately.

5.2 Inspection and Maintenance Schedule



The specified inspection and maintenance intervals (see table) apply to normal crane service conditions.

If routine maintenance reveals that the intervals are too long, they should be adapted to the specific operating conditions.

For repairs, use only genuine Demag parts (see component parts list).

The use of spare parts not approved by Demag renders any warranty claims void.

5.3 Hoist Trolley

Refer to the operating instructions on the following pages for maintenance instructions with inspection intervals. Furthermore the relevant safety and health codes and standards and directives must be complied with.

The component assemblies fitted are listed in the individual "Technical Description" chapters of the corresponding cranes.

The hoist and travel units used are standard Demag products which require little maintenance.

Components which are subject to wear (brakes, ropes, load hooks, etc.) must be checked and inspected as specified in the relevant operating instructions and repaired as required.

The inspection intervals apply to single-shift operation.

5.4 Crane Bridge

Component	Type of inspection	Inspection criteria	Inspection interval		
			Months		
			3	6	12
Crane girder	Visual check	- mechanical damage - check welds for cracks - corrosion protection			x
Travel rail/travel flanges	Visual check	- wear - check welds for cracks - flange deformation			x
Limit stops	Visual check	- damage - tight fit	x		
Wind drift safety devices	Visual check	- damage - tight fit - function			x
Limit switches	Function check	- switching-off - run-on path			x
Safety interlock	Visual check Function	- see Operating Instructions			x
Bolted connections crane girder/travel units	Check tightening torques and property class	- Tightening torques/property classes, data see HV self-adhesive label close to the bolted connection			x
Connections/fittings	Check tightening torques	- see Chapter 12			x
Travel units	Visual check Function Travel wheel flange wear	- maintenance instructions with inspection intervals see operating instructions of the components			x

5.5 Tightening Torque Requirements

For torque requirements of bolted connections also see tables in Section 12.5.

5.6 Control

The relevant international and national electrical codes of practice and regulations must be observed in order to maintain the condition of the entire electrical equipment. Electrical power installations with a rated voltage of up to 1000 V must be inspected by an experienced technician in accordance with these guidelines and at suitable intervals.

Component	Inspection criteria	Inspection interval		
		Months		
		3	6	12
Isolator	- check electrical function - locking device			x
Crane switch/main contactor	- Emergency-Stop actuation - main contactor cut-off			x
Control pendant	- mech. damage - electrical function - fixing of strain relief device			x
Remote control units	- see manufacturer's operating instructions for maintenance instructions			x

Component	Inspection criteria	Inspection interval		
		Months		
		3	6	12
Fuse links	- check specified amperage and tripping characteristics - check close-tolerance bolts on screw cap for tight fit			x
Contactors	- check for contact erosion - check connections for tight fit - check easy movement of magnet system		x	
Transformers	- check connections for tight fit			x
Electrical components	- protective measures			x
Control devices, electrical equipment	- check connections and devices for tight fit - check electrical settings			x
Hoist limit switches, anti-collision devices, by-pass control system, reflectors/light barriers	- check function by approaching/tripping - check run-on paths - check fittings for tight fit - check correct connection orientation - regularly remove dirt accumulation (at shorter intervals, if required) - carry out regular function checks (at shorter intervals, if required)			x
Load detectors	- according to operating instructions			x
Magnet installation, back-up battery, fill level	- maintenance according to operating instructions - visual check			x
Warning devices	- functions - visual check			x
Drive control systems	- see Operating Instructions			x
Timer, frequency, monitoring relays	- functions - operating processes depending on time and frequency		x	

5.7 Power Supply

Component	Inspection criteria	Inspection interval		
		Months		
		3	6	12
Power supply to the crane	- refer to the operating instructions for maintenance instructions			x
Power supply line to the hoist trolley.	- refer to the operating instructions for maintenance instructions			x
Remote control system	- refer to the operating instructions for maintenance instructions			x
Fixed cabling, moving connecting cables	- damaged cables - check screwed glands for tight fit and leaks - check connections on screw terminals/plug-and-socket connections for tight fit - check strain relief device			x
Warning and notice signs	- check condition - legibility			x

5.8 Crane Runway

Component	Type of inspection	Inspection criteria	Inspection interval		
			Months		
			3	6	12
Mains connection switch		- electrical function - locking attachment			x
Foundations	Visual check	- cracks in the floor			x
Supports, brackets, travel rails, flanges	Visual check/ tightening torques	- see Chapter 12 - cracks in welds - mech. deformation			x
Rail joints	Visual check	- offset and fastening			x
Track suspensions	Visual check/ tightening torques	- mechanical damage of suspension rods - securing element of ball nut - connections			x
End stops	Visual check/ function	- damage			x
Corrosion protection	Visual check				x

The owner must be informed if inspection of the crane reveals excessive wear of the travel wheels/wheel flanges.



To compensate any settling, all bolted connections must be tightened one to two months after the crane is first put into service and during routine inspections.

6 Manufacturer, Service and Spare Parts Contact Information

6.1 Manufacturer / Customer Service

Demag Cranes & Components Corp
29201 Aurora Road
Cleveland, OH 44139-1895
Telephone: (440)-248-2400 (9:00 AM to 5:00 PM Eastern)
Fax: (440) 248-3874
Internet: <http://www.demag-us.com>

6.2 Spare Parts

Demag Cranes & Components Corp.
29201 Aurora Road
Cleveland, OH 44139-1895
Telephone: (800)-756-8221 (9:00 AM to 5:00 PM Eastern)
Fax: (800)-945-7278
e-mail: parts@demag-us.com
Internet: <http://www.demag-us.com>

Demag spare parts sets reduce maintenance requirements and ensure functional reliability, a long service life, and high product availability. Quotation requests or orders for spare parts sets can be submitted to your local Demag Dealer, Parts Distributor, or Service Provider. Use our Website for assistance in locating your regional Demag Parts and Service Contact.

For Quotations, please include a crane or component serial number, as well as the original Demag crane or component sales order number.

For safety reasons, only Demag original spare parts and/or Demag approved OEM parts and accessories may be used for maintenance and repair work on Demag cranes and components.

6.3 Service

Demag Service can be located around the clock. Please use our web site at: <http://www.demag-us.com> to locate your regional North American Demag Service Provider.

7 Disassembly and Disposal

7.1 Disassembly



Observe relevant safety regulations and codes of practice when disassembling Demag cranes, see also "Safety instructions" chapter.

Disassembly may only be carried out by appropriately instructed personnel.

The owner must appoint a specialist to supervise the disassembly work, issue instructions and monitor the measures to be carried out.

Isolate the installation in accordance with the relevant electrical regulations and codes of practice.

Secure the disassembly area to prevent adjacent cranes accidentally being driven into it and mark off with barriers at floor level.

Replace the gear unit air vent screws by plug screws.

Only use reliable tools and disassembly tools, equipment and auxiliary materials (also see the "Erection and assembly" chapter for the individual cranes in these operating instructions).

If the crane is to be used again, select tools for disassembly and carry out the disassembly work so that no damage occurs.

Refer to the approval drawing for the weight of the crane.

Disassembly is mainly carried out in reverse order to assembly, also see the "Erection and assembly" chapter for the crane in these operating instructions.

To avoid danger of accidents, disassembly work must not commence until all persons concerned in the surrounding area have been informed.

The owner or his appointed agent must release the working area again once the disassembly work has been completed.

Demag Cranes & Components has experienced specialist personnel and suitable equipment available for carrying out the disassembly work on your behalf.

7.2 Disposal



Waste materials resulting from assembly, installation, maintenance, repair and disassembly work must be disposed of appropriately and in accordance with the relevant laws, regulations and codes of practice.

8 Sound Pressure Level of Cranes

The sound emitted by the drives on the crane does not exceed the sound pressure level of 85 dB(A) permitted at the operator's workplace.

Approximate calculation

The total sound pressure level of a crane is calculated from the sound pressure levels of the individual components such as:

- hoist unit
- cross-travel drive(s)
- long-travel drives
- further individual components such as slewing gear, for example, depending on the mode of operation

Calculation of the total sound pressure level of the crane is based on the sound pressure levels specified in the operating instructions of the individual components. The sound pressure level of the individual components is measured according to DIN 45635.



Influence of distance to source of sound on the sound pressure level

To take structural influences into account, for example the reflection of sound waves from walls, a reduction of approx. 3dB(A) in the sound pressure level is calculated each time the distance to the source of sound is doubled (empirical value in normal enclosed areas).

Add the sound pressure level increase calculated from the sound pressure level difference to the largest previously calculated sound pressure level.

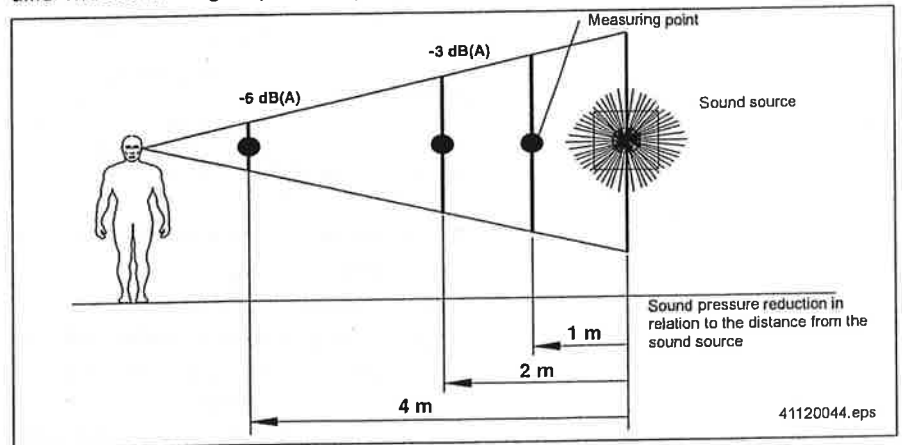

Sound pressure level summation

Several sources are measured in such a way that pairs of sound sources are taken together to be measured in stages and added logarithmically to make up a sum total level. Further sound sources can then be added logarithmically to the previously calculated sum total level.

Table for Logarithmic Addition of Two Sound Pressure Levels

- for same sound pressure		the sound pressure level increases by approx.	3,0	dB(A)
- for sound pressure level difference of	1	the sound pressure level increases by approx.	2,5	dB(A)
	2		2,1	
	3		1,8	
	4		1,5	
	5		1,25	
	6		1	
	7		0,8	
	8		0,6	
	9		0,5	
	10		0,4	

Add the sound pressure level increase calculated from the sound pressure level difference to the largest previously calculated sound pressure level.

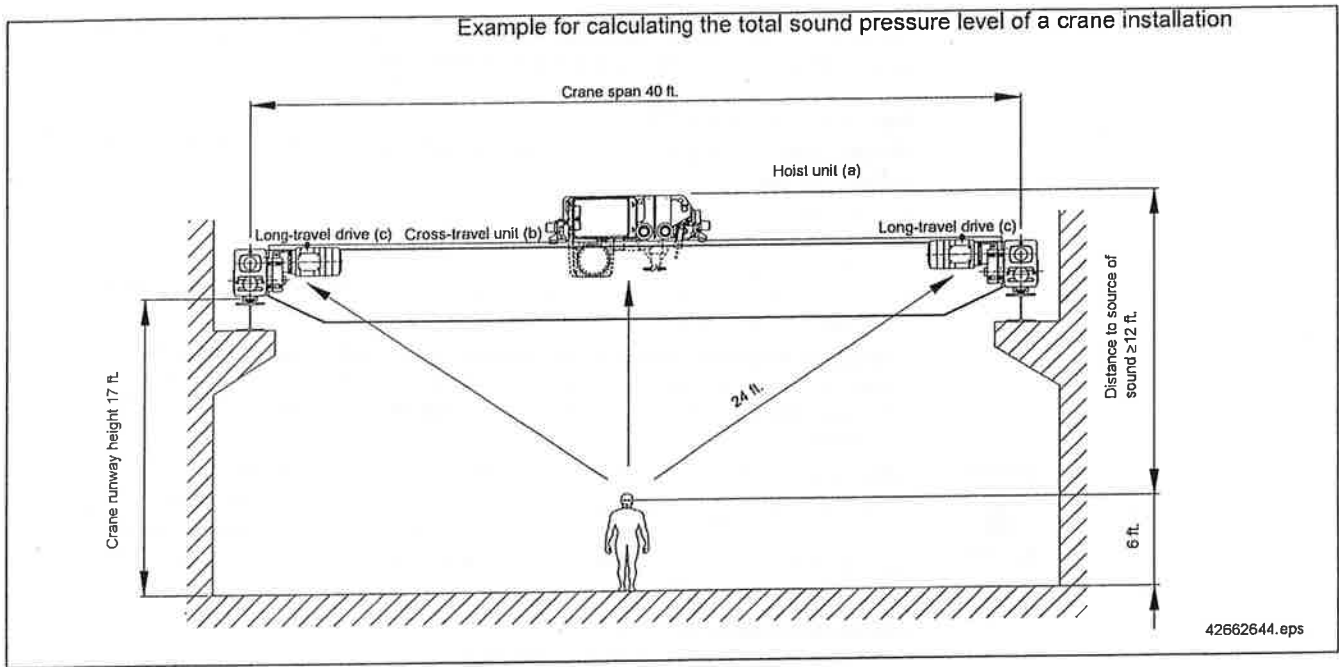

Distance to source of sound	3 ft.	6 ft.	12 ft.	24 ft.	Source of sound	dB(A)	a + b	a + b + c
Hoist unit dB(A)	78	75	72	-	a	72 1)	73,5	75,4
Cross travel unit dB(A)	74	71	68	-	b	68 1)		
2 x long travel unit dB(A)	77 77	74 74	71 71	68 68	c	71 2)	-	

Total sound pressure level for the crane installation = 75.4 dB(A)

Explanation

1. Superimposition of hoist unit and cross-travel drive (a + b)
 Calculated difference: 72 dB(A) – 68 dB(A) = 4 dB(A)
 This difference according to the table for logarithmic addition results in a sound pressure level increase of Δ dB(A) = 1.5 dB(A) over the higher level.
 This results in a total sound pressure level for the hoist unit and cross-travel drive of 72 dB(A) + 1.5 dB(A) = 73.5 dB(A) (a).
2. Total sound pressure level of the long-travel drives (c)
 Both long-travel drives have a sound pressure level of 68 dB(A). According to the table for logarithmic addition, this results in a sound pressure level increase of 3 dB(A). Thus the total sound pressure level of the long-travel drives is 68 dB(A) + 3dB(A) = 71 dB(A) (b)
3. Superimposition of [(a + b) + (c)]
 Calculated difference: 73.5 dB(A) -71 dB(A) = 2.5 dB(A)
 This difference according to the table for logarithmic addition results in a sound pressure level increase of Δ dB(A) = 1.9 dB(A) over the higher level.
4. Total sound pressure level of the crane:
 The total sound pressure level is calculated as follows:
 73.5 dB(A) + 1.9 dB(A) = 75.4 dB(A)

1) Individual sound pressure level
 2) Sum of sound pressure levels for two long-travel drives

9 Electromagnetic Compatibility

Consequences for cranes

European guidelines for electromagnetic compatibility.

Electromagnetic compatibility (EMC) is defined as the ability of an electrical or electronic device to function without failure in an electromagnetic environment without influencing other devices or causing interference in the surroundings beyond certain limits.

When investigating the electromagnetic interference which is caused by operating an electrical device or which may affect it, a distinction is made between sources of interference and potentially susceptible devices. A source of interference is a generator (transmitter) of electromagnetic interference which is either directly emitted or dissipated to the environment via cables and wiring. A source of interference may be, for example, switched inductivity in a contactor, an electronic device (pulse-controlled AC converter) or lightning. A potentially susceptible device absorbs part of the electromagnetic energy and suffers interference or may even be damaged. Many electronic devices are both sources of interference and susceptible devices.

EMC regulations and standards specify a maximum level of interference which an electronic device must not exceed as a source of interference when installed and used in a certain environment, or against which the device must be resistant.

All equipment supplied or put into service as of 1 January 1996 which meets the requirements of the EMC guideline must be marked with the CE conformity symbol of the European Union. The basis for the declaration of conformity are the documented EMC measurements which have to be compiled within the scope of the quality assurance system. They must document that the product or alternative product meets the specified requirements in accordance with the EMC guidelines. This documented qualification has to be proven each time the product is modified. To achieve the specified EMC, manufacturers are required to fit devices with filters or to provide screening.

Plant and switchgear manufacturers and owners are obliged to design and implement installations in line with EMC requirements. Unavoidable interference energy must be dissipated directly to earth (ground). Coupling must be avoided as far as possible.

In state-of-the-art electronic systems, more and more devices are being used which operate at low voltages and high pulse frequencies. Additional HF interference suppression measures are required for these installations. Allowing for EMC as early as possible saves costs. The implementation of decoupling measures in good time is also important as measures which are not allowed for at the planning stage are impossible to create at a later date.

Therefore, before an item of equipment or an installation is built, a concept must be developed which defines the interfaces and includes the quantitative specifications for these interfaces.

This is simply general information and recommendations which should be taken into consideration.

10 Crane Inspections

10.1 Inspection Regulations

National, state, and local inspection regulations must be observed. Refer to OSHA 1910.179, ASME B30.2, CMAA #78, B30.11, B30.16, B30.17, and CSA B167 as applicable.

Inspection reports shall specifically identify the equipment inspected, including its location, manufacturer's serial number and owner's equipment number.

Inspection work may only be performed by qualified inspectors per CMAA #78 Standards and Guidelines for Professional Services Performed on Overhead and Traveling Cranes and Associated Hoisting Equipment.

10.2 Crane Inspections

The Frequent inspection is a visual and operational inspection performed as often as daily, based on service, environmental and application factors, and determined by a qualified person.

10.2.1 Frequent Inspection

The Frequent Inspection shall be performed by a qualified Inspector. The qualified Inspector shall determine whether conditions found during the inspection constitute a hazard and whether a more detailed inspection is required.

Hooks and wire ropes shall be inspected at minimum monthly intervals and documented with a certification record which includes date of inspection, the signature of the person who performed the inspection and the serial number or identifier of the hook or wire rope inspected.

Scope of Frequent Inspection shall include, but not be limited to items in Section 10.2.1 and Section 5.1

10.2.2 Periodic Inspection

A Periodic inspection is a detailed visual and operational inspection whereby individual components are examined to determine their condition. The Periodic Inspection is performed as often as quarterly based on service, environmental and application factors as determined by a qualified person.

The Periodic Inspection shall be performed by a qualified inspector. The qualified Inspector shall determine whether conditions found during the inspection constitute a hazard and whether a more detailed inspection is required.

Reports for Periodic Inspections shall be kept on file by the owner/Purchaser and, if applicable, the service provider.

Proof of Inspection (tags, etc.) shall be affixed to the inspected equipment by the inspector. Proof of inspection shall be plain sight and shall contain the date of the last inspection, name of the inspecting company, if applicable, and the individual that performed the inspection.

Scope of Periodic Inspection should include, but not be limited to, the items in Sections 5.1, 5.4, 5.5, 5.6, and 5.7.

10.2.3 Initial Inspection and Load Test for which the Owner is Responsible

New, reinstalled, altered, repaired, and modified cranes shall be inspected prior to initial use.

- Furthermore the testing must determine that the planned rated and test loads are taken up safely, the resulting forces can be transferred, the crane works properly and the safety devices are effective.
- Load tests are conducted at 125% of rated load and are required.
- Copies of all test reports should be kept in a crane logbook and retained for the lifetime of the equipment.
- To conduct the proper load test:
 - (1) Hoist the test load a distance to assure that the load is supported by the crane and held by the hoist brake(s).
 - (2) Transport the test load by means of the trolley for the full length of the bridge.
 - (3) Transport the test load by means of the bridge for the full length of the runway in one direction with the trolley as close to the extreme right-hand end of the crane as practical, and in the other direction with the trolley as close to the left-hand end of the crane as practical.
 - (4) Lower the test load, and stop and hold the test load with the brake(s).

11 Technical Description

11.1 Crane Types and Subassemblies

Demag cranes are overhead lifting equipment constructed of standardised component assemblies. Their steel structure is designed and built according to DIN 15018 and other relevant standards.

Crane Types

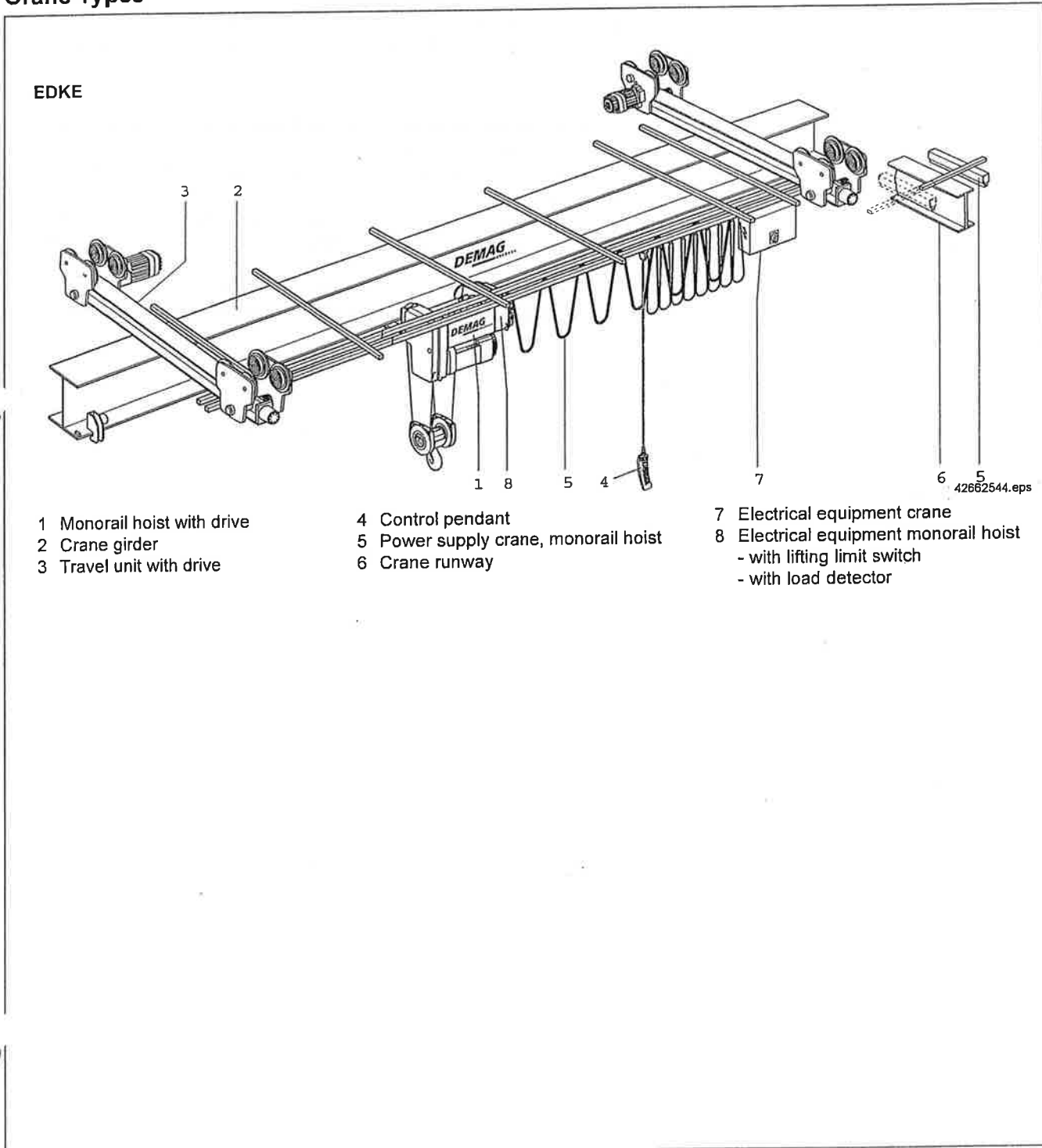

EKKE

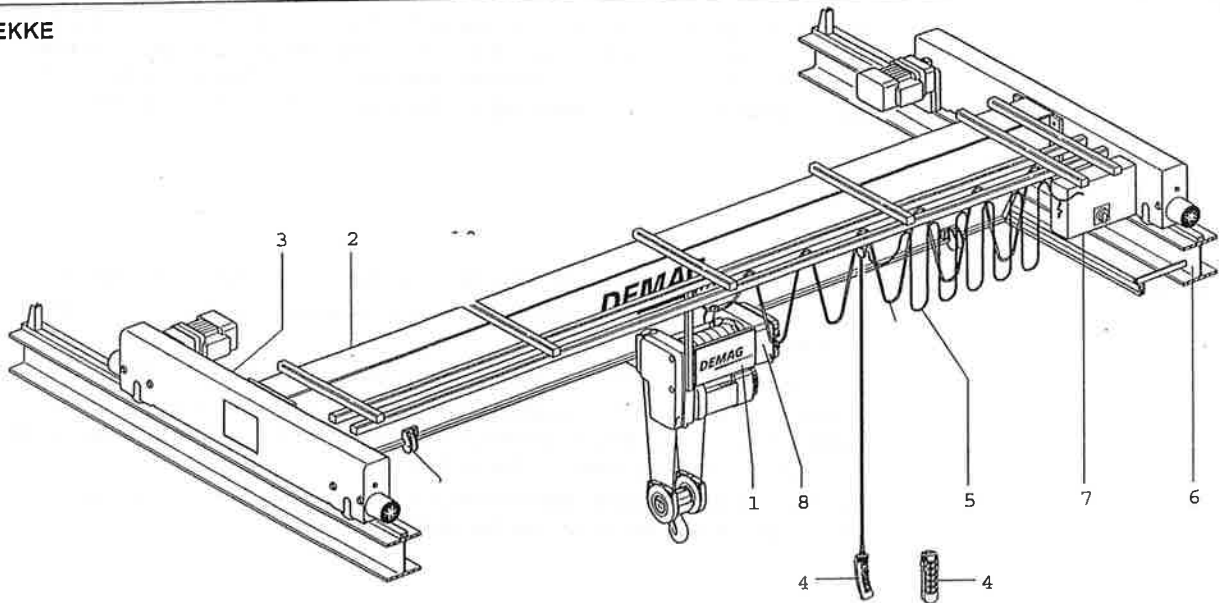

42662244.eps

- 1 Monorail hoist with drive
- 2 Crane girder
- 3 Travel unit with drive

- 4 Control pendant
- 5 Power supply
- 6 Crane runway

- 7 Electrical equipment crane
- 8 Electrical equipment monorail hoist
- with lifting limit switch
- with load detector

ZKKE

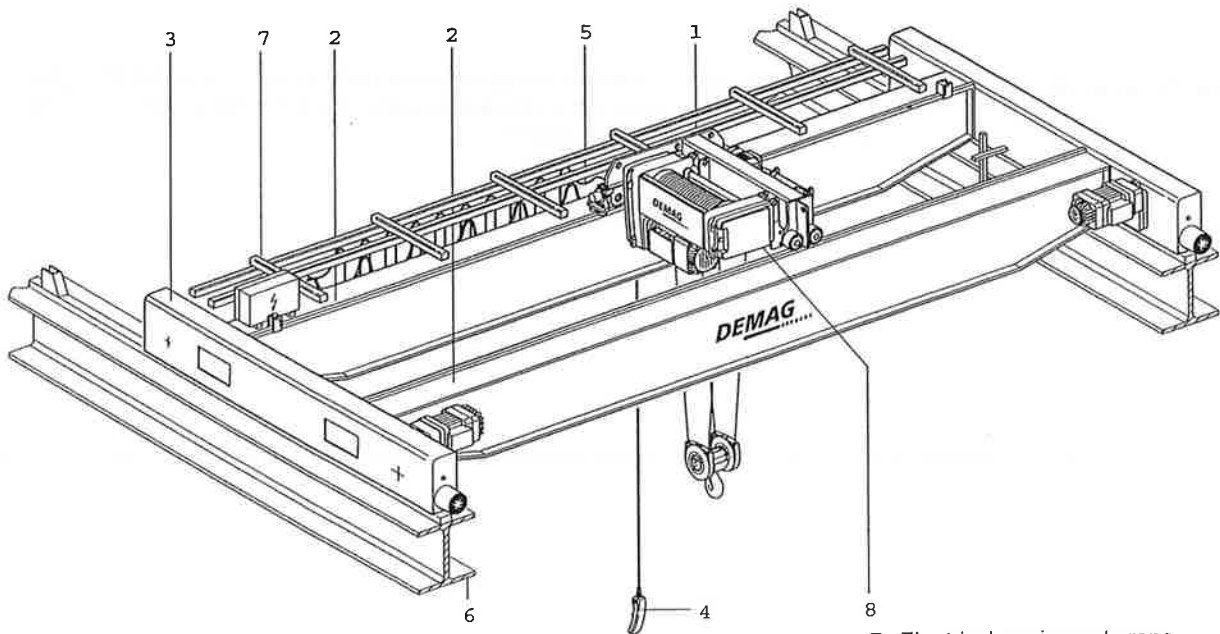

- 1 Crab with drive
- 2 Crane girder
- 3 Travel unit with drive

- 4 Control pendant
- 5 Power supply
- 6 Crane runway

- 7 Electrical equipment crane
- 8 Electrical equipment trolley
- with lifting limit switch
- with load detector

42662344.eps

11.2 General

The subassemblies of Demag cranes are described in these operating instruction: Refer to the type designations and sizes in the approval drawing and, if applicable, the crane test and inspection booklet in order to find the individual subassemblies in the enclosed publications more easily. Here you can also find information on the classification of the crane supporting structure and the monorail hoist/trolley.

11.3 Main Subassemblies

11.3.1 Crane Girder

The steel structure of the single-/double-girder crane is designed to DIN 15018. The classification can be seen from the approval drawing and the crane test and inspection booklet.
The crane girder and the travel units are connected by high-tensile bolts. The perfect crane alignment geometry (prerequisite for good operating characteristics) is guaranteed by exact machining of the connecting surfaces, exact survey and precise adjustment in the factory.
The crane girder is a rolled steel section or a box girder construction which is resistant to bending and torsion for the other crane types.

11.3.2 Monorail Hoist

The monorail hoist travels on the lower flange of the crane girder. The technical description includes the enclosed operating instructions.

11.3.3 Double-Rail Trolley

The trolley runs on two travel rails which are fixed to the upper flanges of the crane girders. The technical description includes the enclosed operating instructions of the double-rail trolley.
Depending on the type, the trolley is driven by a central drive or by individual travel drives (see approval drawing).

11.3.4 Crane Travel Units

Refer to the approval drawing and to the crane test and inspection booklet for the travel unit type used and to the relevant enclosed operating instructions/component parts lists for a technical description.

11.4 Crane Control System

Cable-connected floor control with a control pendant or remote control

Refer to the approval drawing and the test and inspection booklet for the type of control system fitted to the crane.

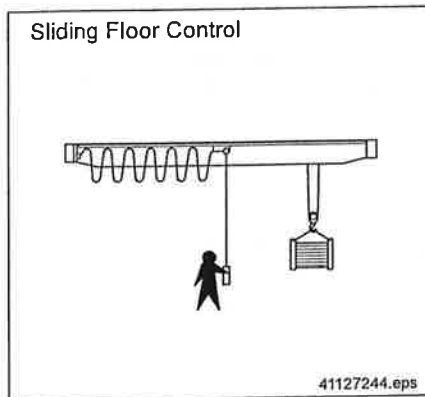

The sliding floor-level control pendant can travel along the crane girder and is located independently of the trolley. It allows the operator to move freely, to avoid obstacles and to maintain safety distances at an optimum position in relation to the load. This type of control is permitted for travel speeds up to 175 ft/min.

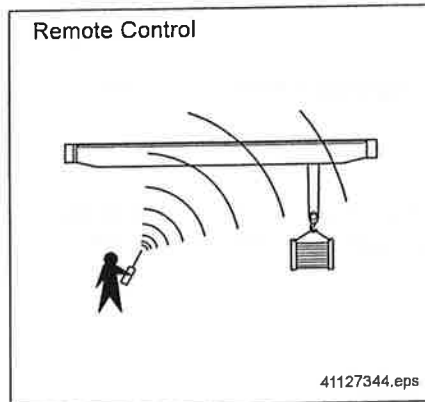

Remote control systems allow the operator to independently control the crane from any position.

This type of control is permitted for travel speeds up to 320 ft/min.

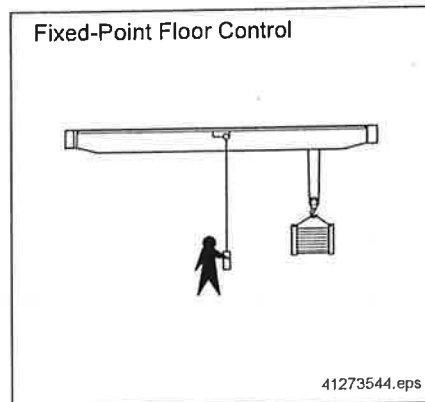

The fixed-point floor control system is used where the operating or travel path runs parallel to the crane runway. In this case direct load guidance by the operator is not always possible.

This type of control should be used only for cranes with small span dimensions and is suitable for travel speeds up to 175 ft/min.

12 Erection and Assembly



Read and comply with this chapter before erection and assembly work is carried out. Refer to "Safety instructions for assembly and disassembly" in the "Safety instructions" chapter.

A coordinator must be appointed before erection and assembly. Knowledge of assembly procedures and appropriate tools are absolutely essential for carrying out erection and assembly work.

Modifications to our subassemblies require our prior written approval. The electrode holder and earth must be connected to the same assembly when welding work is carried out. If the current flow is returned via protective conductors, screening elements or anti-friction bearings, serious damage may be caused to these or other components.

Erection and assembly work may involve an increased risk of accident.

We recommend you have erection and assembly work carried out by Demag trained specialists.

Complex, engineered cranes should only be erected and assembled by or with the help of Demag.

12.1 Delivery

The level of crane assembly at delivery depends mainly on:

- dimensions of crane components
- assembly options purchased
- national and local traffic laws and restrictions.

For information on a specific crane configuration please contact customer service (Section 6.1)

12.2 Crane Runway Tolerances

Minimum requirements for runway installation and alignment tolerances must be met according to CMAA #70, Sec. 1.4 and Table 1.4.2-1 and CMAA #74, Sec. 1.4 and Table 1.4.1-1

12.3 Assembling the Crane Supplied as Subassemblies



First unload the main girder and place it on beams at a height at which the trolley/monorail hoist can be mounted on level ground. In addition, refit the power supply to the monorail hoist/trolley and the mobile control system which may have been removed for transport reasons.

Secure the main girder against falling over – risk of accident.



The counterbores in the end carriages and the compensating washers fixed in the main girder must be free of rust, dirt, oil, paint and other contaminants prior to assembly.

In accordance with the stencilled assembly marks, place the end carriages in position against the main girder and secure them.



Use a pin to check alignment of the bore holes for the high-tensile bolted connections (never use fingers - risk of injury).

Fit a high-tensile washer onto each high-tensile steel bolt included in the scope of supply and insert the bolts into their respective holes from the inside by passing them through the access holes in the end carriages. Fit another HV high-tensile washer on the opposite side before bolting on the HV high-tensile nut. Ensure that the bevelled side of the HV high-tensile washer faces the bolt head/nut



Then tighten the nuts using a torque wrench to the tightening torques specified in table, section 13.5.2.

Lost or damaged high-tensile bolts, high-tensile nuts and high-tensile washers must only be replaced by items bearing the high-tensile symbol (HV) according to DIN EN 14399-4/14399-6 and the material designation (see section “High-tensile bolted connections”).

It must be ensured that

- black bolts are only used with black nuts and black washers,
- galvanized bolts are only used with galvanized nuts and galvanized washers as a set from one manufacturer.

Place a washer under the head of each bolt and under each nut as indicated in the “High-tensile bolted connections” section.



Ensure that the side of the washer stamped with HV faces away from the underside of the bolt head or the nut to avoid cracks forming in the bolts.

12.4 Bolted Connections

12.4.1 DFW-L-E, DFW-L-Z and DFW-L-T with Side Cconnection

For tightening torques, see the "High-tensile bolted connections" table on page 44.

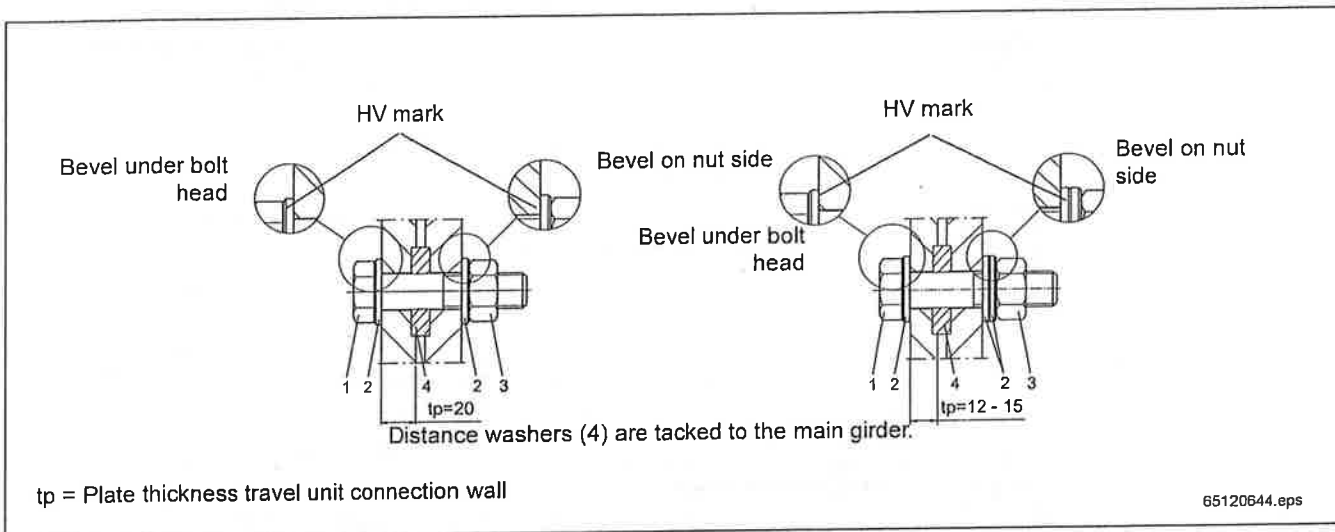

Only permanently marked connecting elements with the following DIN designations may be used:

Preferred range M 20 (galvanized).

- 1 Hexagon bolt M 20 x 85 x 46 (Special length of thread 46 mm), DIN EN 14399-4
Strength class 10.9 HV tZn
Demag part no.: 152 802 99
- 2 Washer 21 x 37 x 4, DIN EN 14399-6
Strength class C 45 V HV tZn
Demag part no.: 152 806 99
- 3 Hexagon nut M 20, DIN EN 14399-4
Strength class 10 HV tZn
Demag part no.: 316 209 99
- 4 Distance washer 22 x 50 x 10,
Minimum tensile strength 520 N/mm²
Demag part no.: 810 762 44

12.4.2 KTD-E

For tightening torques, see the "High-tensile bolted connections" table on page 44.

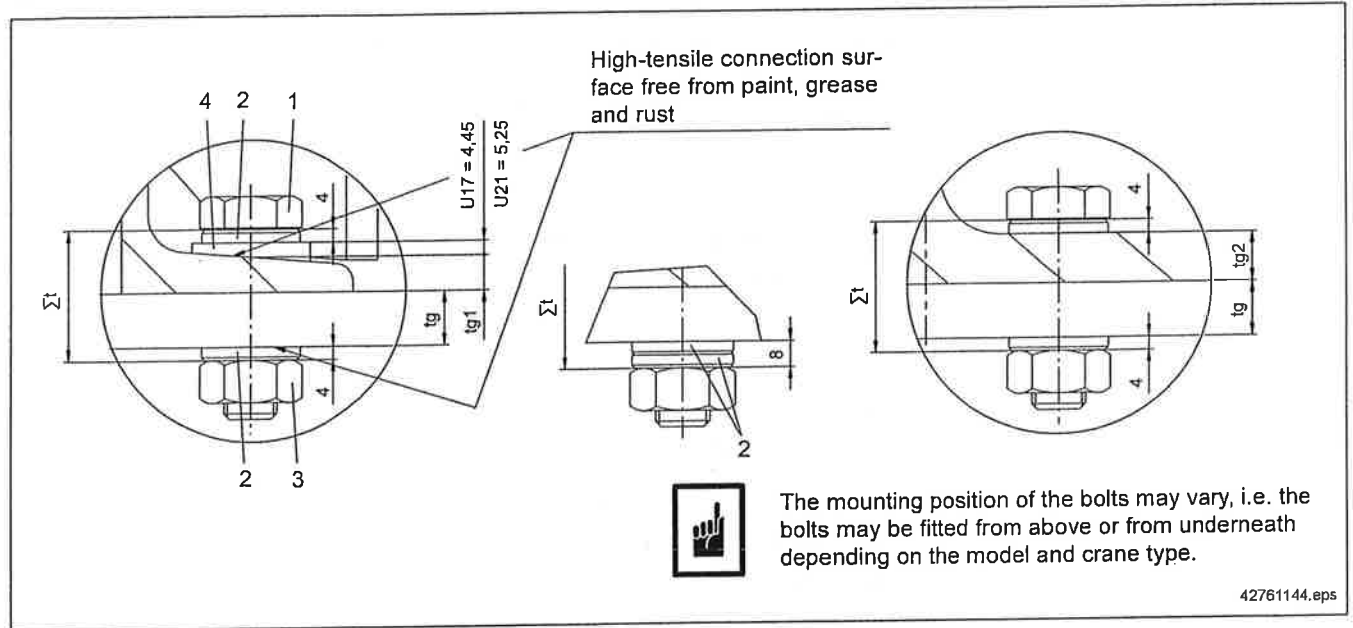

Only permanently marked connecting elements with the following DIN designations may be used:



- 1 Hexagon bolt M 16 x 55, DIN EN 14399-4
Strength class 10.9 HV tZn
Demag part no. 150 707 99
- 1 Hexagon bolt M 16 x 60, DIN EN 14399-4
Strength class 10.9 HV tZn
Demag part no. 316 121 99
- 1 Hexagon bolt M 16 x 65, DIN EN 14399-4
Strength class 10.9 HV tZn
Demag part no. 151 858 99
- 1 Hexagon bolt M 20 x 65, DIN EN 14399-4
Strength class 10.9 HV tZn
Demag part no. 151 946 99
- 1 Hexagon bolt M 20 x 75, DIN EN 14399-4
Strength class 10.9 HV tZn
Demag part no. 152 801 99

The mounting position of the bolts depends on the crane type and varies, see adhesive label on the travel unit

- 2 Washer 17 x 30 x 4, DIN EN 14399-6
Strength class HV tZn
Demag part no. 150 731 99
- 2 Washer 21 x 37 x 4, DIN EN 14399-6
Strength class HV tZn
Demag part no. 152 806 99
- 3 Hexagon nut M 16, DIN EN 14399-4
Strength class 10 HV tZn
Demag part no. 316 201 99
- 3 Hexagon nut M 20, DIN EN 14399-4
Strength class 10 HV tZn
Demag part no. 316 209 99
- 4 Washer U17 x 32 x 36, DIN 6918
Strength class C45tZn HV
Demag part no. 152 811 99
- 4 Washer U21 x 40 x 44, DIN 6918
Strength class C45tZn HV
Demag part no. 322 088 99

12.5 Tightening Torques

12.5.1 Standard Bolted Connections

Solid shaft bolts (without high-tensile bolts) with metric standard thread to DIN 13, part 13. Tightening torques to VDI 2230, sheet 1, July 1986.

For other friction coefficients see VDI 2230, sheet 1, table 1, page 70, July 1986.
 $\mu_G = 0,12$ as average friction value in the thread.

Thread		M 5	M 6	M 8	M 10	M 12	M 16	M 20	M 24	M 27	M 30
Property class		Tightening torque									
		Nm	Nm	Nm	Nm	Nm	Nm	Nm	Nm	Nm	Nm
8.8	μ_k 0.08	4.3	7.4	18.0	36	61	145	300	510	750	1000
	μ_k 0.10	4.9	8.5	20.5	41	71	170	350	600	880	1190
	μ_k 0.12	5.5	9.0	23.0	46	79	195	390	670	1000	1350
	μ_k 0.14	6.1	10.4	25.0	51	87	215	430	740	1100	1500
10.9	μ_k 0.08	6.3	10.9	26.0	52	90	215	420	730	1070	1450
	μ_k 0.10	7.3	12.5	30.0	60	104	250	490	850	1250	1700
	μ_k 0.12	8.1	14.0	34.0	68	117	280	560	960	1400	1900
	μ_k 0.14	8.9	15.5	37.0	75	130	310	620	1060	1550	2100
12.9	μ_k 0.08	7.4	12.5	31.0	61	105	250	500	850	1250	1700
	μ_k 0.10	8.5	14.5	35.0	71	121	300	580	1000	1450	2000
	μ_k 0.12	9.5	16.5	40.0	79	135	330	650	1120	1650	2250
	μ_k 0.14	10.4	18.0	43.0	87	150	370	720	1240	1850	2500

Thread		M 5	M 6	M 8	M 10	M 12	M 16	M 20	M 24	M 27	M 30
Property class		Tightening torque									
		FtLbs.	FtLbs.	FtLbs.	FtLbs.	FtLbs.	FtLbs.	FtLbs.	FtLbs.	FtLbs.	FtLbs.
8.8	μ_k 0.08	3.2	5.5	13.3	27	45	107	222	377	555	740
	μ_k 0.10	3.6	6.3	15.2	30	53	126	259	444	651	881
	μ_k 0.12	4.1	6.7	17.0	34	58	144	289	496	740	999
	μ_k 0.14	4.5	7.7	18.5	38	64	159	318	548	814	1110
10.9	μ_k 0.08	4.7	8.1	19.2	38	67	159	311	540	792	1073
	μ_k 0.10	5.4	9.3	22.2	44	77	185	363	629	925	1258
	μ_k 0.12	6.0	10.4	25.2	50	87	207	414	710	1036	1406
	μ_k 0.14	6.6	11.5	27.4	56	96	229	459	784	1147	1554
12.9	μ_k 0.08	5.5	9.3	22.9	45	78	185	370	629	925	1258
	μ_k 0.10	6.3	10.7	25.9	53	90	222	429	740	1073	1480
	μ_k 0.12	7.0	12.2	29.6	58	100	244	481	829	1221	1665
	μ_k 0.14	7.7	13.3	31.8	64	111	274	533	918	1369	1850

Friction coefficients for mating of materials
 μ_k = friction value in the head contact surface

μ_k	Bolt head material	Matching material
0,08	Steel, black, pressed or turned	AlMg, bright, cut, dry
0,1	Steel, black, pressed or turned, oiled Steel, galvanized, pressed, dry or oiled	Steel, bright, cut, dry GG/GTS, bright, cut, dry
0,12	Steel, black, pressed, dry	Steel, bright, cut, dry
0,14	Steel, black, pressed, oiled Steel, galvanized, pressed, dry	GG/GTS bright, cut, dry Steel, galvanized, cut, dry

12.5.2 High-Tensile Bolted Connections

High-strength hexagon head bolts with large widths across flats for structural steel bolting according to DIN EN 14399-4 and 14399-6. With metric standard thread according to DIN 13, part 12 and 15 (supporting material steel).

Thread	Property class	Prestressing forces F_w				Tightening torque M_A			
		1) Black & oiled		2) Hot-dip galvanized & lubricated with MoS ₂		1) Black & oiled		2) Hot-dip galvanized & lubricated with MoS ₂	
		kN	kps	kN	kps	Nm	FtLbs.	Nm	FtLbs.
M 16	10.9	93.3	21.0	100	22.5	284	210.2	250	185.0
M 20		145.6	32.7	160	36.0	554	410.0	450	333.0
M 22		180.1	40.5	190	42.7	762	563.9	650	481.0
M 24		209.8	47.2	220	49.5	958	708.9	800	592.0
M 27		272.8	61.3	290	65.2	1420	1050.8	1250	925.0

12.5.3 Verbus Ripp / Durlock Bolted Connections

Assembly prestressing forces F_M and tightening torques M_A for locking bolts and nuts according to works standard 011 891 99 and 011 892 99 (VERBUS RIPP system and DURLOCK)

Thread	Property class	Prestressed forces F_w		Tightening torque M_A for steel supporting material $R_m < 800 \text{ N/mm}^2$ (116 ksi) GG, GGG, GD AIDi 12 Cu					
		N	lbs	Nm	FtLbs.	Nm	FtLbs.	Nm	FtLbs.
M 5	100 (10.9)	9,000	2,020	11.0	8.1	9.0	6.7	9.0	6.7
M 6		12,600	2,830	19	14	16	12	18	13
M 8		23,200	5,220	42	31	35	26	45	33
M 10		37,000	8,320	85	63	75	56	75	56
M 12		54,000	12,140	130	96	115	85	120	89
M 16	12.9 (DURLOCK)	102,000	22,930	330	244	300	222	330	244
M 20		180,900	40,670	720	533.0	720	533.0	-	-

R_m = Minimum tensile strength in N/mm^2

See relevant drawings and maintenance instructions for product-specific tightening torques.

1) Values to DIN 15018 part 1 page 20 of November 1984

2) Values to DIN 18800 part 7 page 3 of May 1983 and DAst 010 of June 1976

12.6 Example for Installing the Crane on the Runway

12.6.1 Single-Girder Crane



The assembly tools and lifting tackle must be suitable for the deadweight of the crane. Refer to the approval drawing for the weight.

An installation jig (fig. 651 207 44) clamped to the upper flange can be used for installing the crane.

Alternatively, nylon or wire rope slings appropriate for the weight of the crane must be used (ensure edges are protected).

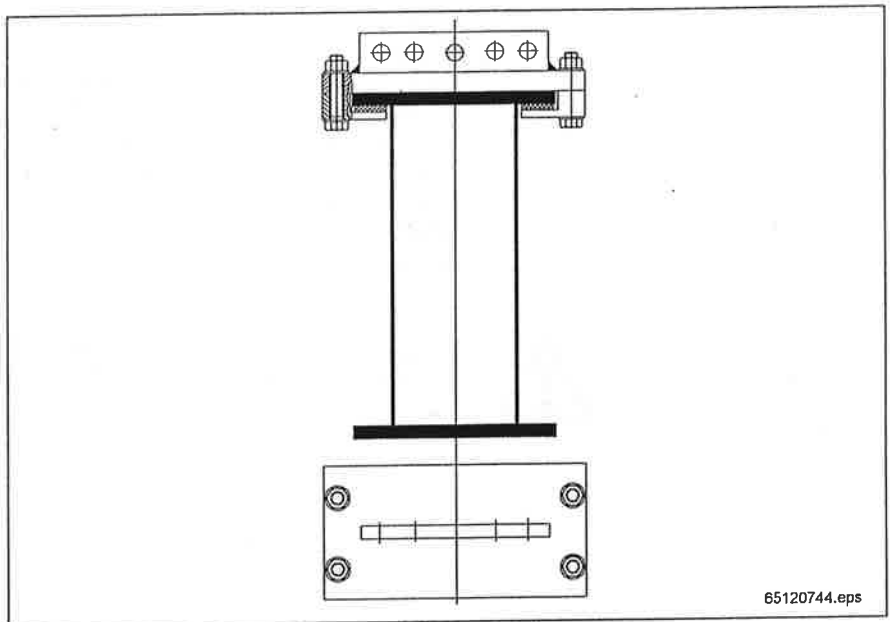

12.6.2 Double-Girder Crane



The assembly tools and lifting tackle must be suitable for the deadweight of the crane. Alternatively, nylon or wire rope slings appropriate for the weight of the crane must be used (ensure edges are protected).

Use appropriate means to prevent the main girders being pressed together when lifting double-girder cranes (ensure edges are protected).

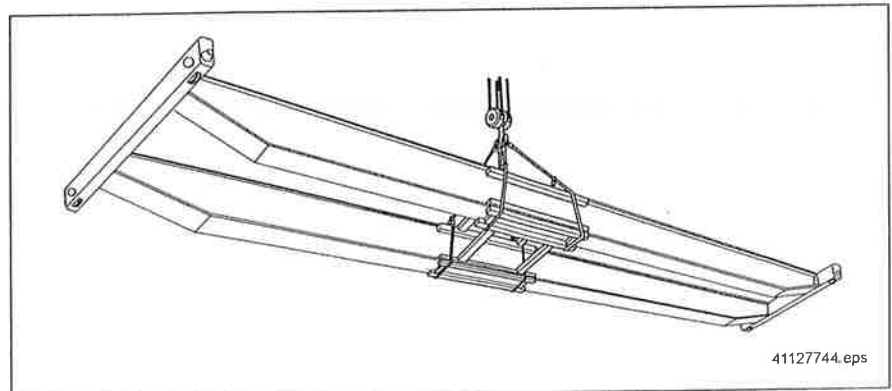

13 Putting into Service for the First Time Following Assembly on Site

13.1 Notes and Inspections

Adjust the limit switches to allow for run-on.

Adjust any additional operating limit switches fitted to hoist units so that they operate before the emergency limit switches come into operation.

Optimize the factor settings of all adjustable control units to meet specific application requirements. The settings must be entered into the circuit diagram by the person responsible for commissioning and notification of the settings sent to the design department of Demag Cranes & Components.

Check the protective earth conductor along its entire length for continuity, correct marking and connection.

Check that the fuse links fitted are of the correct amperage and have the correct tripping characteristics, see specifications in the equipment list.

Replace the plug screws at the highest points of the gearboxes with the air vent screws provided.

When assembly has been completed, check the clearance of the crane and crab or travelling hoist along their entire length of travel.

Carefully check, for example, that the crane travels smoothly over splices in the runway, that the current collectors have good contact, that the trailing cable system runs easily and that safety distances to parts of the building and machinery are maintained.

Before putting the crane into service for the first time, the insulation resistance and loop impedance must have been measured (EN 60204).



To compensate any settling, all bolted connections must be tightened one to two months after the crane is first put into service and during routine inspections.

14 Sample Checklist

Crane no. _____

Inspection regulations: see accident prevention regulations BGV D6, VDE 0100 part 726 and other relevant regulations		Inspection remark
Power supply data: voltages, frequency (see approval drawing)		checked
Bolted connections checked		checked
in particular high-tensile bolts on end carriage (high-tensile washers checked for correct fit: bevel facing bolt head/nut)		checked
Guide roller spacing adjusted, screwed connection (torque) checked		checked
Crane, crab and runway end buffers installed and correctly positioned		checked
Crane and crab end approach dimensions checked (see approval drawing)		checked
Hook height checked (see approval drawing) and reset if necessary		checked
Gearbox checked for leaks, air vent screws fitted		checked
Chain/rope reeving, rope mounting checked (rope wedge, rope clamp)		checked
Chain/rope lightly oiled		checked
Chain/rope and cable deflectors mounted (if part of crane equipment)		checked
Emergency and operating limit switches (for lifting and lowering) adjusted		checked
Long and cross travel limit switches adjusted (if applicable)		checked
Optical crane distancing adjusted (if applicable)		checked
Control pendant height and remote control strain relief (if applicable) checked		checked
Control panel symbols match actual crane travel movements		checked
Direction of movement symbols attached (for remote control units only)		checked
Accessibility, marking and availability of "mains connection switches" and "emergency-off switches"		checked
Check protective earth conductor along entire length for correct marking and connection		checked
Cable entry glands in terminal boxes correctly wired		checked
Control and regulating devices	(If optimized, enter values in wiring diagram and inform DCC)	checked
Overload measuring system	(If optimized, enter values in wiring diagram and inform DCC)	checked
Relay settings	(If optimized, enter values in wiring diagram and inform DCC)	checked
Resistor settings	(If optimized, enter values in wiring diagram and inform DCC)	checked
Check and tighten terminals (not clamp terminals, however)		checked
Safety distances to other parts of the building and machinery are maintained		checked
Smooth running over splices in the runway and of power supply lines		checked
Brake check carried out:	lifting and lowering (run-on allowed for)	checked
Brake check carried out:	long and cross travel (run-on allowed for)	checked
Speed checks:	lifting, lowering, long and cross travel	checked
Crane signs (on crane and load handling attachments, load capacity observed)		checked
Paint coat checked and touched up where required		checked
Operation of wind drift safety device (for cranes operating outdoors) tested		checked
(Strain relief, torque setting, travel direction, smooth running,		checked
Cable length, 2 reserve windings required at lowest hook position)		checked
Warning device (if available)		checked
Assembly/workplace tidied (packing material disposed of in accordance with regulations)		completed
Handover including power supply and permanently laid supply line		on:
Handover without power supply and with provisionally laid supply line		on:
Remarks:		
Date: _____ Name: _____ Signature: _____		

Notes



Operating instructions

DFW-L-E and DFW-L-Z endtrucks with DRS

Manufacturer

Mannesmann Dematic Corp.
 29201 Aurora Road, Solon, Ohio 44139
 Telephone (440) 248-2400, Fax (440) 248-3086
 Internet <http://www.dematic-us.com>

Please fill in the following table before first putting into service
 This provides you with definitive documentation of your endtruck and important information if you ever have to contact the manufacturer or his representative.

Owner
Where in use
Travel wheel diameter
Wheel base (ekt)
Part number (if existing)
Gearbox designation (i.e. AME 20 D)
Motor designation (i.e. ZBF 90 B 8/2)
Travelling speed
Operating voltage
Mains frequency

Further documents

EC Manufacturer's declaration DFW-L-E	237 490 44	
EC Manufacturer's declaration DFW-L-Z	237 491 44	
DFW-L-E endtruck	229 254 49	714 IS 845.1
DFW-L-Z endtruck	229 256 49	714 IS 845.1
DRS wheel block system	203 350 44	714 IS 845

Component parts lists

DFW-L-E endtrucks	229 248 49	721 IS 845.1
DFW-L-Z endtrucks	229 258 49	721 IS 845.1
DRS 112 wheel block	229 204 49	721 IS 845.5
DRS 125 wheel block	229 205 49	721 IS 845.5
DRS 160 wheel block	229 206 49	721 IS 845.5
DRS 200 wheel block	229 207 49	721 IS 845.5
DRS 250 wheel block	222 928 44	721 IS 845.5
DRS 315 wheel block	222 932 44	721 IS 845.5
DRS 400 wheel block	222 936 44	721 IS 845.5
A..10 gearboxes	229 210 49	721 IS 983.1
A..20 gearboxes	229 211 49	721 IS 983.1
A..30 gearboxes	229 212 49	721 IS 983.1
A..40 gearboxes	229 213 49	721 IS 983.1
A..50 gearboxes	229 214 49	721 IS 983.1
Z.. motors size 63	229 240 49	721 IS 919
Z.. motors size 71	229 241 49	721 IS 919
Z.. motors size 80	229 242 49	721 IS 919
Z.. motors size 90	229 243 49	721 IS 919
Z.. motors size 100	229 245 49	721 IS 919
Z.. motors size 112	229 246 49	721 IS 919
Z.. motors size 132	229 247 49	721 IS 919

Operating instructions

DRS wheel block	214 276 44	720 IS 845.5
(A. and Z..) offset gearmotors	229 200 49	720 IS 983

Foreword



You have purchased a Mannesmann Dematic product. This equipment was manufactured in accordance with state-of-the-art engineering principles.

These operating instructions are designed to provide the operator with appropriate instructions for safe and correct operation and to facilitate maintenance.

Every person given the task of transporting, installing, commissioning, operating, maintaining and repairing our products and additional equipment must have read and understood

- the operating instructions
- the safety regulations and
- the safety instructions in the individual chapters and sections.

The operating instructions must be available to the operating personnel at all times in order to prevent operating errors and to ensure smooth and trouble-free operation of our products.

For safety information on this product, see

206 751 44; 720 IS 100
206 752 44; 720 IS 100
206 753 44; 720 IS 100

Safety instructions

Symbols

The following symbols and recommendations indicate potential safety hazards or causes of damage, or provide useful information.



Hazard warning

This symbol appears in the operating instructions next to all instructions relating to safety at work wherever a potential hazard to life and limb exists.

Follow these instructions at all times and be particularly careful and cautious.

Pass on safety instructions to all persons entrusted with working on the crane, the runway and the power supply system.

In addition to the safety instructions, observe all general safety regulations at all times.



Operating hazard for the installation

This symbol in the operating instructions indicates all warnings which, if not complied with, may result in damage to the crane or the load.

Description

Demag endtrucks are designed according to state-of-the-art dynamically loaded components. They are the result of systematic development and up-to-date design. All design and production processes as well as the components are subject to permanent comprehensive quality assurance in accordance with DIN ISO 9001.

Operation

Inside a building, outdoor operation.

Supporting structure

The steel structure is designed and built according to DIN 15018, lifting class H2, stress group B3 (other classes on request). The endtruck girder is of box-girder design and resists bending and torsional stresses. It is connected to a crane girder by means of high-tensile bolts.

Travel drives

The practically maintenance-free flange-guided individual drive units directly drive the endtruck. The special Demag winding of the motor ensures smooth starting of the endtruck.

Electrical key data

Operating voltage: 230V, 460V, 575V; control voltage: 42V, 48V, 110V, 230V; frequency: 60Hz; type of enclosure: IP54.

Corrosion protection

As standard, the steel structure parts are provided for corrosion protection with a synthetic resin coating (layer thickness 60 µm; color: RAL 1004/golden yellow) after thorough pre-treatment (purity class Sa 2 to DIN 55928), the same applies to the travel drives (RAL 5009/azure blue).

Accident prevention



The relevant accident prevention regulations and the codes of practice have to be complied with for operation and maintenance of Demag endtrucks.

In addition, the following items have to be ensured:

- Unlock any locking devices, if fitted, before starting operation.
- In the event of a hazard, switch off the mains connection switch.
- Safety equipment does not relieve the operating personnel from the need to be cautious. The endtruck (crane) has to be operated as if the safety equipment were not fitted.
- The endtruck (crane) must not be used for tearing free, pulling, dragging or pulling loads at an angle.
- At the end of operation, the endtruck (crane) must be moved to the required standstill position. Any locking devices (if required) must be applied and the endtruck must be switched off.

In accordance with the relevant accident prevention regulations, a maintenance access arrangement (stationary or mobile) must be provided for maintenance and repair of endtrucks (cranes).

Maintenance work must only be carried out on unloaded endtrucks. and when the mains connection switch has been switched off and secured and locked against unauthorized switching on. The mains connection switch of our endtrucks provides the possibility of fitting several padlocks so that any person working on the endtruck (crane) can secure the switch with his own padlock.

Any stipulated inspection and maintenance work required for accident prevention purposes and safe operation of the endtruck must not be delayed or omitted.

Regardless of any other operating instructions for individual sub-assemblies (drives, motors, etc.), the inspection intervals of the maintenance schedule apply to all parts of the endtruck. They are valid for normal endtruck operating conditions. For more arduous operation, the maintenance intervals have to be shortened as required.

Weather influence and dirt accumulation

Our endtrucks are intended for use in the following operating conditions:

- ± 0 °C to +40 °C (32 °F to 104 °F)
- Air humidity up to 80%
- Installation height up to 1000 m (3300 ft) above sea level

Other operating conditions are possible after clarification of the measures required to be taken.

General



Travelling operation must be stopped if safe operation (controlled handling of the endtruck) can no longer be guaranteed due to adverse weather conditions.

First deposit loads safely.

During thunderstorms it is forbidden to walk on crane runway(s) and crane(s). It is also forbidden to leave the cab, if any.

Cranes sometimes operating outdoors



For endtrucks that operate mostly indoors and only some of the time outdoors a wind protection device is not necessary.

When a storm or strong winds are approaching, the operator must move the endtruck into shelter in the building in good time.

Cranes operating outdoors

Endtrucks operating all or most of the time outdoors are equipped with wind protection devices.

The wind protection device(s) must be engaged on finishing work, during longer interruptions to work or when a storm or strong winds are approaching.

We suggest that cranes for outdoor usage should be kept under shelter when not in operation.

Influence of weather and dirt on runways

For safety reasons, all runways must be kept clear of oil, grease and/or dirt, since such contamination impairs the start-up and braking of cranes and endtrucks.

Influence of winter weather on runways

For the same reason all runways must also, if necessary, be freed of ice and snow before starting operation.

Check the function of current collectors and the power supply before starting up and, if necessary, de-ice them in a disconnected state.

Viscous oil may impair or prevent crane or endtruck start-up.

De-ice frozen brakes on travelling gears before starting work or, if necessary, after long downtimes and apply the brakes "warm."

Precautionary measures to ensure safe crane operation are the responsibility of the owner.

Technical data

Overview

Demag DFW endtrucks are compact, driven, rail-mounted endtrucks for direct connection to load-bearing structures.

The endtruck design is based on the latest principles for box structures and, even with high loads, has excellent travelling characteristics due to the fine tolerances of the endtruck regarding track gauge errors, diagonal position and misalignment.

The endtruck includes a Demag DRS wheel block for fitting the gearbox and the motor as well as the non-driven DRS wheel block.

Specially adapted heavy-duty motors provide excellent speed/torque characteristics, which ensure smooth starting for both the unloaded and the loaded endtruck.

Connection of main girder/endtruck

Only a crane of perfect geometrical alignment can perform with smooth travel characteristics. Therefore care has to be exercised when endtrucks are fitted to the crane girders, in order to maintain the accuracy adhered to during manufacturing.

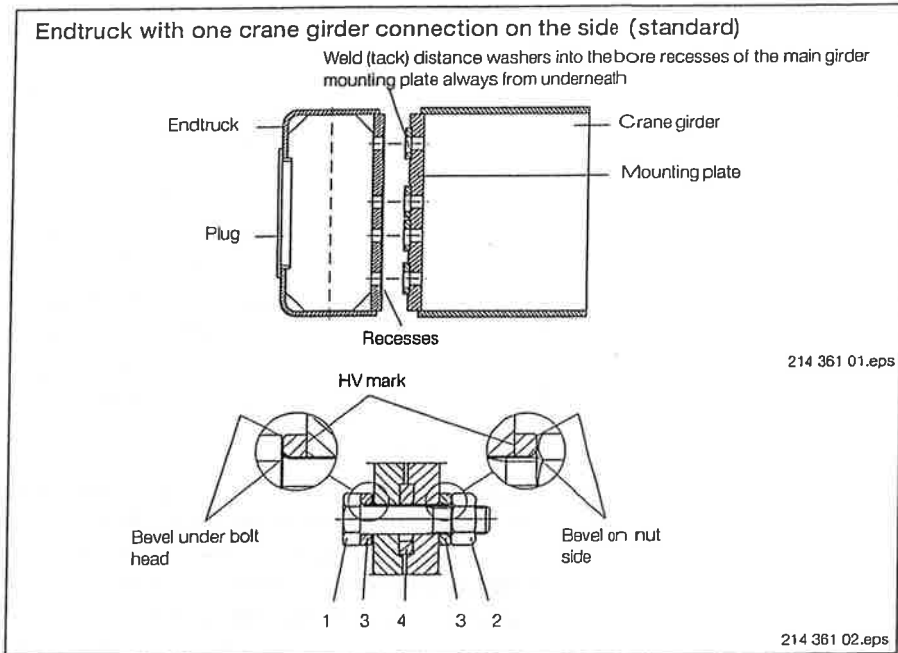

The recesses on the endtruck and the distance washers on the mounting surfaces of the connecting sleeves and the bore holes in the girder mounting plates must be free from rust, dust, grease, paint and other contaminants.

Bolted connection variant:

- Remove plugs from the access holes.
- Weld (tack) distance washers into the bore recesses of the main girder mounting plate always from underneath.
- Connect endtruck and main girder as shown in the above illustration (bolt heads inside endtruck).

Use exclusively the following parts which are supplied with the endtruck:

- 1 Hexagon head screw M20 x 85 x 46 DIN 6914 property class 10.9 HV
- 2 Hexagon nut M20 DIN 6915 property class 10 HV
- 3 Hardened washers 21 x 37 x 8 DIN 6916 property class C45 V HV
- 4 Distance washers 22 x 50 x 10 tensile strength 520 N/mm²

- Tighten diagonal pairs of screws with torque wrench. Tightening torque: 554 Nm (409 lb ft)
- Close access holes with fitting plugs.
- For operation outdoors, seal the gap between the endtruck and the mounting plate on the top and on the side with silicone.



Jacking up the endtruck

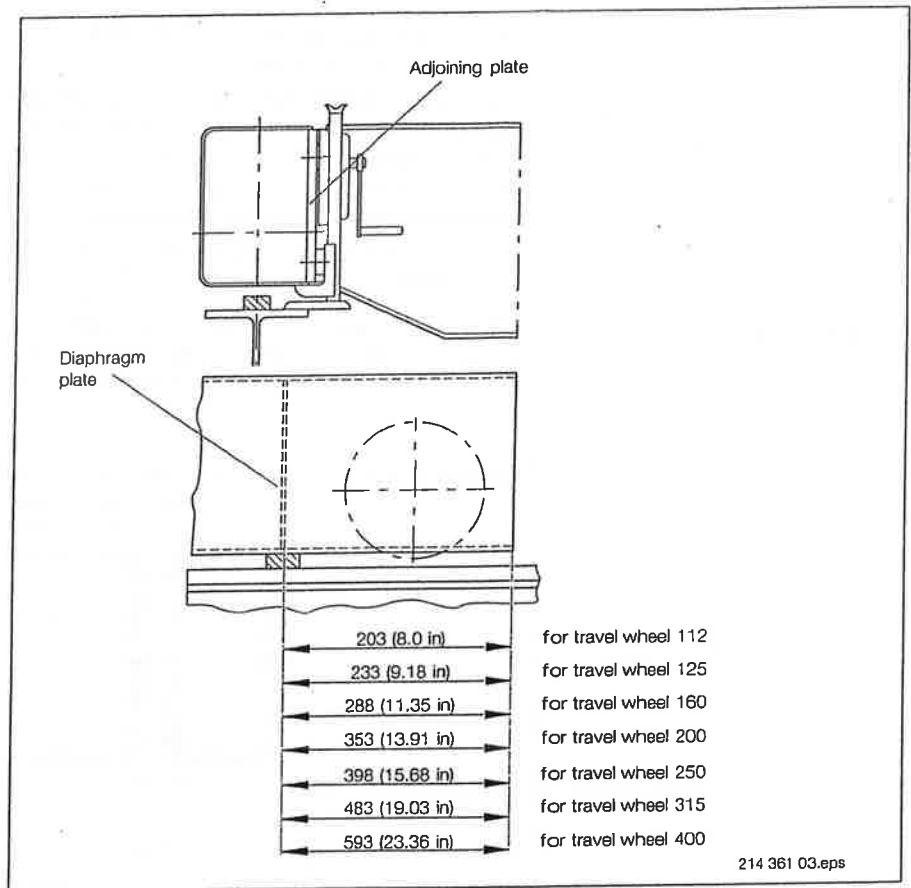

Jacking-up the endtruck is necessary for certain fitting operations so that the load is removed from the travel wheels (wheel block).

For this purpose, a winch or similar hoisting unit is applied below the diaphragm plate of the endtruck girder and the endtruck is lifted.

Lifting the endtruck so that the wheel just clears the crane rail is sufficient.

The rased endtruck should be held in position by placing spacers between rail and endtruck underside at points where the endtruck is strengthened with diaphragm plates to prevent it from being damaged.



Technical description

Demag DRS wheel block system

The travel unit consists of a DRS wheel block on the non-drive side and a DRS wheel block with drive kit (torque arm set, gearbox and motor) on the driven side.

Together with the torque arm set, the gearbox connection provides different mounting positions relative to the wheel block. The drive shaft transmits the torque directly into the splined travel wheel hub with virtually no play via a splined journal shaft.

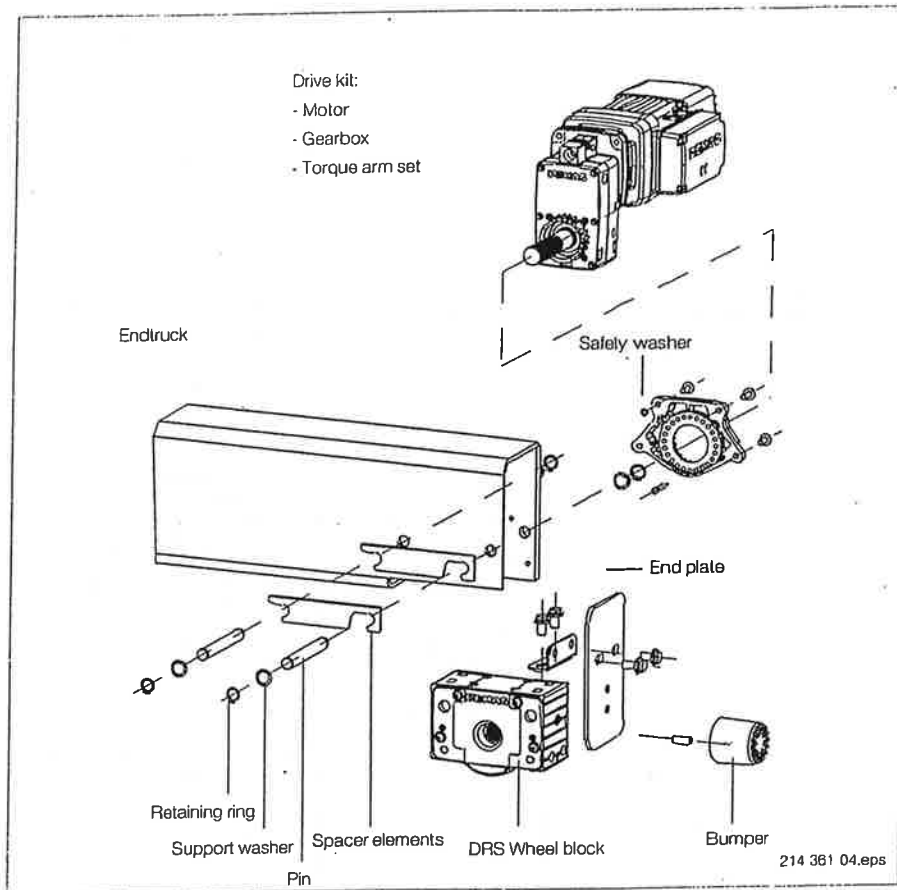

Removing the Demag DRS wheel block system

- Jack up the endtruck girder (see page 7).
- Loosen bolted connection on torque arm set (optional, only on drive side) and pull off gearbox.
- Unscrew bumper and end plate.
- Remove retaining rings, support washers and any shims
- Remove spacer elements (mark left and right side).
- Pull out pins
- Roll wheel block out of endtruck.

Fitting the Demag DRS wheel block system

- Slide wheel block into endtruck.
 - Insert pins
 - Fill gap between endtruck and wheel block with spacer elements (note marks).
 - Slide on support washers, retaining rings and any shims (see fig. 214 361 06.eps).
 - Fit bumper and end plate.
 - Clean drive shaft and grease shaft splining with grease DG 69 (part no. 472 915 44) before fitting gearmotor.
 - Slide in gearmotor with torque bracket.
 - Bolt torque arm set together with endtruck and tighten with the following tightening torques:
- | | | |
|--------------------|-----------|---------------------|
| MA112-1 to MA125-2 | screw M8 | Ma=35 Nm (26 lb ft) |
| MA160-1 to MA200-1 | screw M10 | Ma=65 Nm (48 lb ft) |



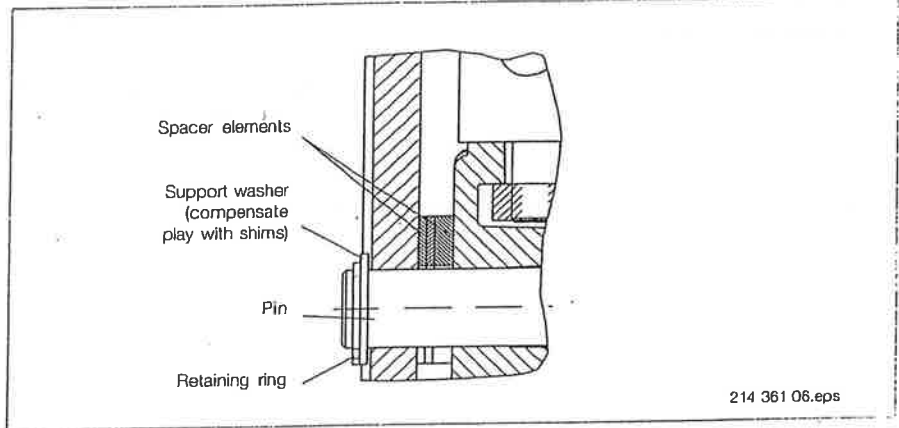

Adjusting the span
Demag DRS wheel block system

By re-arranging the spacer elements, the span can be adjusted. The standard as-signment and the max. adjustment possibilities are specified in the following table.

DFW	Measurements in mm (in)		
	b4	b	Max. adjustment
112	70 (2.76)	10 (0.39)	± 6 (0.24)
125	70 (2.76)	6 (0.24)	± 4 (0.16)
160	85 (3.35)	15 (0.59)	± 6 (0.24)
200	95 (3.74)	15 (0.59)	± 10 (0.39)
250	105 (4.14)	10 (0.39)	± 6 (0.24)
315	125 (4.93)	15 (0.59)	± 10 (0.39)
400	140 (5.52)	15 (0.59)	± 10 (0.39)

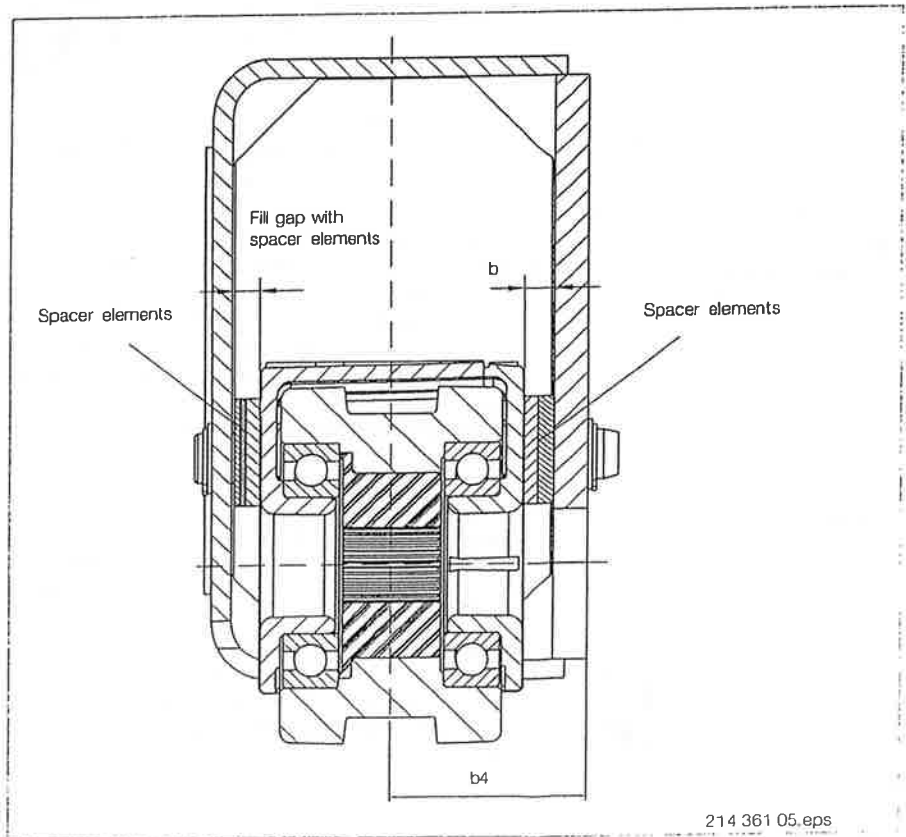

Maintenance

Routine inspections

In accordance with the accident prevention regulations for cranes and the principles of the inspections by experienced technicians (ZH 1/27).

Component	Type of inspection	Inspection item	Inspection interval		
			Months		
			3	6	12
Limit stops	Visual inspection	- damage - tight fit	x		
Limit switches	Function check	- cut-off - run-on path			x
Main girder/endtruck bolted connections	Check tightening torques; check property class	- tightening torques/ properly classes, for data see adhesive spec. plate near bolted connection			x
Connections/attachments	Check tightening torques	- Works standard, Standard tightening torques Ident. no. 011 938 99			x
Endtrucks	Visual inspection Function Travel wheel flange wear	- for maintenance instructions with inspection intervals and repairs, see operating instructions of components			x

Wheels

Demag DFW endtrucks provide the possibility of adjusting the travel wheels or the DRS wheel blocks in the axial direction, i.e. for adjusting the span (see Adjusting the span). The travel wheel flange wear mark indicates sufficiently in advance when the travel wheel must be replaced. In conjunction with the next scheduled inspection, preventive measures can therefore be taken to ensure the availability of the installation..

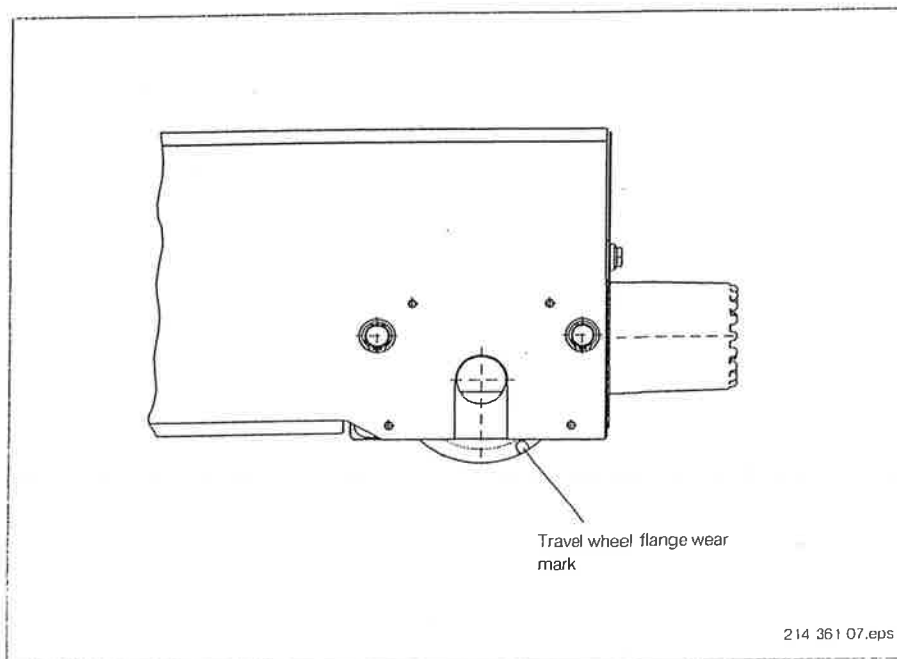

Wheel blocks

The DRS wheel blocks are maintenance-free, due to their technical design. For further information, see DRS wheel block system documents (see page 2).

Disposal



Waste materials resulting from assembly, installation, maintenance, repair and disassembly work must be disposed of appropriately and in accordance with the relevant laws, regulations and codes of practice.

In addition to relevant local statutory and other regulations and guidelines, the following must be observed:

- Never pour harmful waste fluids such as oil, grease and poisonous chemical substances into the waste system nor allow them to disperse into the ground.
- Always pour waste oil and grease into the appropriate containers
- Always put spent batteries, scrap appliances such as electronic components and plastic materials in the appropriate containers.