



**GROVE**®  
worldwide

*100-TON*  
**LOADCHARTS**  
**RT9100**

**GVW**  
**133,711 lbs**

**85% STABILITY**  
**ON OUTRIGGERS**

**75% STABILITY**  
**ON RUBBER**

79139  
**SERIAL NUMBER**

# NOTES FOR LIFTING CAPACITIES

## GENERAL:

1. Rated loads as shown on lift chart pertain to this machine as originally manufactured and equipped. Modifications to the machine or use of optional equipment other than that specified can result in a reduction of capacity.
2. Construction equipment can be hazardous if improperly operated or maintained. Operation and maintenance of this machine shall be in compliance with the information in the operator's parts and safety manual supplied with this machine. If these manuals are missing, order replacements from the manufacturer through the distributor.
3. The operator and other personnel associated with machine shall fully acquaint themselves with the latest American National Standards Institute (ANSI) Safety Standards for cranes.

## SETUP:

1. The machine shall be leveled on a firm supporting surface. Depending on the nature of the supporting surface, it may be necessary to have structural supports under the outrigger floats or tires to spread the load to a larger bearing surface.
2. For outrigger operation, outriggers shall be properly extended with tires raised free of crane weight before operating the boom or lifting loads.
3. If machine is equipped with front jack cylinder, the front jack cylinder shall be set in accordance with written procedure.
4. When equipped with extendable counterweight, the counterweight shall be fully extended before operation.
5. Tires shall be inflated to the recommended pressure before lifting on rubber.
6. With certain boom and hoist tackle combinations, maximum capacities may not be obtainable with standard cable lengths.
7. Do not travel with crane boom extension or jib erected unless otherwise noted. Refer to "Operator's and Safety Handbook".

## OPERATION:

1. Rated loads at rated radius shall not be exceeded. Do not tip the machine to determine allowable loads. For clamshell or concrete bucket operation, weight of bucket and load must not exceed 80% of rated lifting capacities.
2. All rated loads have been tested to and meet minimum requirements of SAE J1063 OCT80 - Cantilevered Boom Crane Structures - Method of Test, and do not exceed 85% of the tipping load on outriggers as determined by SAE J765 OCT80 Crane Stability Test Code.
3. Rated loads include the weight of hookblock, slings and auxiliary lifting devices and their weights shall be subtracted from the listed rating to obtain the net load to be lifted. When more than the minimum required hoist reeving is used, the additional rope weight shall be considered part of the load to be handled.
4. Load ratings are based on freely suspended loads. No attempt shall be made to move a load horizontally on the ground in any direction.
5. Rated loads do not account for wind on lifted load or boom. It is recommended when wind velocity is above 20 m.p.h. (32km/h), rated loads and boom lengths shall be appropriately reduced.
6. Rated loads are for lift crane service only.
7. Do not operate at a radius or boom length where capacities are not listed. At these positions, the machine may overturn without any load on the hook.
8. The maximum load which can be telescoped is not definable because of variations in loadings and crane maintenance, but it is safe to attempt retraction and extension within the limits of the capacity chart.
9. When either boom length or radius or both are between values listed, the smallest load shown at either the next larger radius or next longer or shorter boom length shall be used.
10. For safe operation, the user shall make due allowances for his particular job conditions, such as: soft or uneven ground, out of level conditions, high winds, side loads, pendulum action, jerking or sudden stopping of loads, hazardous conditions, experience of personnel, two machine lifts, traveling with loads, electric wires, etc. Side pull on boom or jib is extremely dangerous.
11. If machine is equipped with individually controlled powered boom sections, the boom sections must be extended equally at all times.
12. Handling of personnel from the boom is not authorized except with equipment furnished and installed by Grove Worldwide.
13. Keep load handling devices a minimum of 18 inches (45.7 cm) below boom head at all times.
14. The boom angle before loading should be greater than the loaded boom angle to account for deflection.
15. Capacities appearing above the bold line are based on structural strength and tipping should not be relied upon as a capacity limitation.
16. Capacities for the 36 ft. (11.0 m) boom length shall be lifted with boom fully retracted. If boom is not fully retracted, capacities shall not exceed those shown for the 42 ft. (12.8 m) boom length.

## DEFINITIONS:

1. Operating Radius: Horizontal distance from a projection of the axis of rotation to the supporting surface before loading to the center of the vertical hoist line or tackle with load applied.
2. Loaded Boom Angle (Shown in Parenthesis on Main Boom Capacity Chart): is the angle between the boom base section and the horizontal, after lifting the rated load at the rated radius with the rated boom length.
3. Working Area: Areas measured in a circular arc about the center line of rotation as shown on the working area diagram.
4. Freely Suspended Load: Load hanging free with no direct external force applied except by the lift cable.
5. Side Load: Horizontal force applied to the lifted load either on the ground or in the air.

**RATED LIFTING CAPACITIES IN POUNDS**  
**36 FT. - 114 FT. BOOM**

**ON OUTRIGGERS FULLY EXTENDED - 360°**

Radius in Feet	#0001									
	Main Boom Length in Feet									
	36	42	51	60	69	78	87	96	105	114
10	200,000 (67)	121,500 (70.5)	114,000 (74)	107,500 (77)	103,000 (79)					
12	176,000 (63)	120,000 (67.5)	110,000 (71.5)	101,500 (75)	99,300 (77.5)	93,650 (79.5)				
15	151,000 (57.5)	115,000 (63)	102,000 (68)	92,100 (72)	90,250 (75)	84,500 (77)	73,350 (79)			
20	116,000 (47)	99,800 (54.5)	90,050 (61.5)	78,650 (67)	76,850 (70.5)	70,500 (73)	62,750 (75.5)	60,000 (77.5)	56,100 (79)	43,850 (80)
25	88,300 (34)	80,100 (45.5)	73,850 (55)	68,900 (61.5)	66,250 (66)	60,150 (69.5)	54,250 (72)	52,250 (74.5)	48,650 (76)	40,950 (77.5)
30		65,650 (34)	61,400 (47.5)	57,650 (55.5)	55,400 (61)	52,400 (65)	46,900 (68.5)	44,900 (71)	42,900 (73)	35,100 (75)
35		52,500 (16.5)	52,500 (38.5)	49,700 (49.5)	46,600 (56)	44,950 (61)	41,150 (65)	39,200 (68)	37,300 (70)	30,400 (72)
40	See Note 16		41,050 (28.5)	41,050 (42.5)	40,300 (51)	38,550 (56.5)	36,550 (61)	34,650 (64.5)	32,800 (67)	26,650 (69.5)
45				33,100 (34.5)	33,100 (45)	33,100 (52)	32,400 (57)	30,950 (61)	29,150 (64)	23,600 (66.5)
50				27,200 (24)	27,200 (38.5)	27,200 (47)	27,200 (53)	27,200 (57.5)	26,150 (61)	21,350 (63.5)
60					19,200 (20)	19,200 (35)	19,200 (43.5)	19,200 (49.5)	19,200 (54.5)	17,300 (57.5)
70						14,100 (16.5)	14,100 (32)	14,100 (41)	14,100 (47)	14,100 (51.5)
80							10,550 (12.5)	10,550 (29.5)	10,550 (38.5)	10,550 (44)
90									7,770 (27.5)	7,770 (35.5)
100										5,580 (24.5)
Minimum boom angle (deg.) for indicated length (no load)										0
Maximum boom length (ft.) at 0 deg. boom angle (no load)										114

NOTE: ( ) Boom angles are in degrees.

A6-829-011720

#LMI operating code. Refer to LMI manual for instructions.

**RATED LIFTING CAPACITIES IN POUNDS**  
**36 FT. - 114 FT. BOOM**

**ON OUTRIGGERS FULLY EXTENDED - OVER FRONT**

Radius in Feet	#0001									
	Main Boom Length in Feet									
	36	42	51	60	69	78	87	96	105	114
10	200,000 (67)	121,500 (70.5)	114,000 (74)	107,500 (77)	103,000 (79)					
12	176,000 (63)	120,000 (67.5)	110,000 (71.5)	101,500 (75)	99,300 (77.5)	93,650 (79.5)				
15	151,000 (57.5)	115,000 (63)	102,000 (68)	92,100 (72)	90,250 (75)	84,500 (77)	73,350 (79)			
20	116,000 (47)	99,800 (54.5)	90,050 (61.5)	78,650 (67)	76,850 (70.5)	70,500 (73)	62,750 (75.5)	60,000 (77.5)	56,100 (79)	43,850 (80)
25	88,300 (34)	80,100 (45.5)	73,850 (55)	68,900 (61.5)	66,250 (66)	60,150 (69.5)	54,250 (72)	52,250 (74.5)	48,650 (76)	40,950 (77.5)
30		65,650 (34)	61,400 (47.5)	57,650 (55.5)	55,400 (61)	52,400 (65)	46,900 (68.5)	44,900 (71)	42,900 (73)	35,100 (75)
35		53,200 (16.5)	53,200 (38.5)	49,700 (49.5)	46,600 (56)	44,950 (61)	41,150 (65)	39,200 (68)	37,300 (70)	30,400 (72)
40	See Note 16		46,750 (28.5)	43,300 (42.5)	40,300 (51)	38,550 (56.5)	36,550 (61)	34,650 (64.5)	32,800 (67)	26,650 (69.5)
45				39,600 (34.5)	35,800 (45)	33,750 (52)	32,400 (57)	30,950 (61)	29,150 (64)	23,600 (66.5)
50				34,750 (24)	32,750 (38.5)	30,150 (47)	28,650 (53)	27,600 (57.5)	26,150 (61)	21,350 (63.5)
60					25,950 (20)	25,850 (35)	23,500 (43.5)	22,100 (49.5)	21,200 (54.5)	17,300 (57.5)
70						19,400 (16.5)	19,400 (32)	18,750 (41)	17,500 (47)	14,150 (51.5)
80							14,850 (12.5)	14,850 (29.5)	14,850 (38.5)	11,700 (44)
90									11,500 (27.5)	9,810 (35.5)
100										8,230 (24.5)
Minimum boom angle (deg.) for indicated length (no load)										0
Maximum boom length (ft.) at 0 deg. boom angle (no load)										114

NOTE: ( ) Boom angles are in degrees.

A6-829-011721

#LMI operating code. Refer to LMI manual for instructions.

# ON RUBBER CAPACITIES WITH 33.25 x 35 TIRES

## STATIONARY CAPACITIES - 360°

Radius in Feet	#9005						
	Main Boom Length in Feet						
	36	42	51	60	69	78	87
10	94,050 (67)	94,050 (70.5)	94,050 (74)				
12	77,250 (63)	77,250 (67.5)	77,250 (71.5)	77,250 (75)			
15	54,050 (57.5)	54,050 (63)	54,050 (68)	54,050 (72)	54,050 (75)		
20	<b>32,150 (47)</b>	<b>32,150 (54.5)</b>	<b>32,150 (61.5)</b>	<b>32,150 (67)</b>	<b>32,150 (70.5)</b>	<b>24,550 (73)</b>	
25	21,050 (34)	21,050 (45.5)	21,050 (55)	21,050 (61.5)	21,050 (66)	21,050 (69.5)	19,600 (72)
30		14,350 (34)	14,350 (47.5)	14,350 (55.5)	14,350 (61)	14,350 (65)	14,350 (68.5)
35		10,300 (16.5)	10,300 (38.5)	10,300 (49.5)	10,300 (56)	10,300 (61)	10,300 (65)
40			7,440 (28.5)	7,440 (42.5)	7,440 (51)	7,440 (56.5)	7,440 (61)
45				5,260 (34.5)	5,260 (45)	5,260 (52)	5,260 (57)
50				3,570 (24)	3,570 (38.5)	3,570 (47)	3,570 (53)
60					1,100 (20)	1,100 (35)	1,100 (43.5)

NOTE: ( ) Boom angles are in degrees.

A6-829-011866

#LMI operating code. Refer to LMI manual for instructions.

1. Capacities are in pounds and do not exceed 75% of tipping loads as determined by test in accordance with SAE J765 OCT80.
2. Capacities are applicable to machines equipped with 33.25 x 35 (32 PR) bias ply tires, at 80 psi cold inflation pressure.
3. Defined Arc - Over front includes 6° on either side of longitudinal centerline of machine.
4. Capacities appearing above the bold line are based on structural strength and tipping should not be relied upon as a capacity limitation.
5. Capacities are applicable only with machine on firm level surface.
6. On rubber lifting with boom extensions or jibs not permitted.
7. For pick and carry operation, boom must be centered over front of machine, mechanical swing lock engaged and load restrained from swinging. When handling loads in the structural range with capacities close to maximum ratings, travel should be reduced to creep speeds.
8. Axle lockouts must be functioning when lifting on rubber.
9. All lifting depends on proper tire inflation, capacity and condition. Capacities must be reduced for lower tire inflation pressures. See lifting capacity chart for tire used. Damaged tires are hazardous to safe operation of crane.
10. Creep - not over 200 ft. of movement in any 30 minute period and not exceeding 1 mph.

	No Load Stability Data	Main Boom 114 ft.
Front (No Load)	Min. boom angle (deg.) for indicated length	24.5
	Max. boom length (ft.) at 0 deg. boom angle	105
360 Deg. (No Load)	Min. boom angle (deg.) for indicated length	43
	Max. boom length (ft.) at 0 deg. boom angle	60

# ON RUBBER CAPACITIES WITH 33.25 x 35 TIRES

## STATIONARY CAPACITIES - DEFINED ARC OVER FRONT (SEE NOTE 3)

Radius in Feet	#9005									
	Main Boom Length in Feet									
	36	42	51	60	69	78	87	96	105	114
10	94,050 (67)	94,050 (70.5)	94,050 (74)							
12	88,150 (63)	77,250 (67.5)	77,250 (71.5)	77,250 (75)						
15	79,650 (57.5)	56,100 (63)	56,100 (68)	56,100 (72)	56,100 (75)					
20	66,150 (47)	54,750 (54.5)	54,750 (61.5)	48,550 (67)	36,450 (70.5)	24,550 (73)				
25	51,050 (34)	51,050 (45.5)	51,050 (55)	43,700 (61.5)	34,750 (66)	24,550 (69.5)	19,600 (72)			
30		36,450 (34)	36,450 (47.5)	36,450 (55.5)	33,050 (61)	24,550 (65)	19,600 (68.5)			
35		27,650 (16.5)	27,650 (38.5)	27,650 (49.5)	27,650 (56)	24,550 (61)	19,600 (65)			
40			21,650 (28.5)	21,650 (42.5)	21,650 (51)	21,650 (56.5)	19,600 (61)			
45				17,300 (34.5)	17,300 (45)	17,300 (52)	17,300 (57)	17,300 (61)		
50				14,000 (24)	14,000 (38.5)	14,000 (47)	14,000 (53)	14,000 (57.5)	14,000 (61)	14,000 (63.5)
60					9,370 (20)	9,370 (35)	9,370 (43.5)	9,370 (49.5)	9,370 (54.5)	9,370 (57.5)
70						6,220 (16.5)	6,220 (32)	6,220 (41)	6,220 (47)	6,220 (51.5)
80							3,950 (12.5)	3,950 (29.5)	3,950 (38.5)	3,950 (44)
90									2,240 (27.5)	2,240 (35.5)

NOTE: ( ) Boom angles are in degrees.

A6-829-011865

#LMI operating code. Refer to LMI manual for instructions.

# ON RUBBER CAPACITIES WITH 33.25 x 35 TIRES

PICK & CARRY CAPACITIES - UP TO 2.5 MPH  
BOOM CENTERED OVER FRONT (SEE NOTE 7)

Radius in Feet	#9006									
	Main Boom Length in Feet									
	36	42	51	60	69	78	87	96	105	114
10	104,500 (67)									
12	99,800 (63)	77,250 (67.5)								
15	84,000 (57.5)	72,800 (63)								
20	65,450 (47)	65,450 (54.5)								
25	51,050 (34)	51,050 (45.5)	51,050 (55)	51,050 (61.5)	51,050 (66)					
30		36,450 (34)	36,450 (47.5)	36,450 (55.5)	36,450 (61)					
35		22,300 (16.5)	22,300 (38.5)	22,300 (49.5)	22,300 (56)	22,300 (61)	22,300 (65)	22,300 (68)		
40			18,500 (28.5)	18,500 (42.5)	18,500 (51)	18,500 (56.5)	18,500 (61)	18,500 (64.5)	18,500 (67)	18,500 (69.5)
45				15,450 (34.5)	15,450 (45)	15,450 (52)	15,450 (57)	15,450 (61)	15,450 (64)	15,450 (66.5)
50				12,900 (24)	12,900 (38.5)	12,900 (47)	12,900 (53)	12,900 (57.5)	12,900 (61)	12,900 (63.5)
60					9,010 (20)	9,010 (35)	9,010 (43.5)	9,010 (49.5)	9,010 (54.5)	9,010 (57.5)
70						6,110 (16.5)	6,110 (32)	6,110 (41)	6,110 (47)	6,110 (51.5)
80							3,880 (12.5)	3,880 (29.5)	3,880 (38.5)	3,880 (44)
90								2,110 (7)	2,110 (27.5)	2,110 (35.5)

NOTE: ( ) Boom angles are in degrees.

A6-829-011867

#LMI operating code. Refer to LMI manual for instructions.

## 33 FT. FIXED EXTENSION

### ON OUTRIGGERS FULLY EXTENDED - 360°

Radius in Feet	33 ft. LENGTH		
	#0051	#0052	#0053
	2° OFFSET	15° OFFSET	30° OFFSET
25	*25,000 (80)		
30	23,800 (79)	*17,150 (80)	
35	21,650 (77)	16,500 (79.5)	
40	19,850 (75)	14,800 (77.5)	12,550 (80)
45	18,450 (72.5)	13,250 (75)	11,500 (78)
50	17,350 (70.5)	12,000 (73)	10,550 (75.5)
60	13,950 (66)	10,100 (68.5)	9,050 (71)
70	11,250 (61.5)	8,630 (64)	7,850 (66.5)
80	9,350 (57)	7,420 (59)	6,860 (61.5)
90	7,860 (51.5)	6,440 (54)	6,040 (56.5)
100	6,650 (46)	5,620 (48.5)	5,350 (50.5)
110	5,520 (40)	4,920 (42.5)	4,760 (44)
120	4,010 (33.5)	4,010 (35)	4,010 (36.5)

A6-829-011881

NOTE: ( ) Boom angles are in degrees.

\*This capacity is based upon maximum boom angle.

#LMI operating code. Refer to LMI manual for instructions.

1. All capacities above the bold line are based on structural strength of boom extension.
2. 33 ft. boom extension length may be used for double or single line lifting service.
3. Rated load is based on loaded main boom angle with reference to horizontal, regardless of main boom length. (Ref. radius is for fully extended 114 ft. boom length only.) **WARNING:** Operation of this machine with heavier loads than the capacities listed is strictly prohibited. Machine tipping with boom extension occurs rapidly and without advance warning.
4. Capacities listed are with outriggers fully extended.

5. **BOOM EXTENSION WARNING:** For main boom length greater than 96 ft. with 33 ft. fixed length boom extension in working position, the boom angle must not be less than 30° since loss of stability will occur causing a tipping condition. The boom angle is not restricted for main boom length equal to or less than 96 ft. This warning also applies for boom extension erection purposes.

### LINE PULLS AND REEVING INFORMATION

HOISTS	CABLE SPECS.	PERMISSIBLE LINE PULLS
Main & Aux. Model 30	3/4" (19 mm) 18x19Class or 35x7 Rotation Resistant Min. Breaking Str. 64,600 lbs.	12,920 lbs.

### WEIGHT REDUCTIONS FOR LOAD HANDLING DEVICES

33 FT. BOOM EXTENSION WITH 36 FT.-114 FT. BOOM	
*Stowed -	787 lbs.
*Erected -	6,267 lbs.

33 FT. - 58 FT. BOOM EXTENSION	
*Stowed -	1,087 lbs.
*Erected (Retracted) -	9,322 lbs.
*Erected (Extended) -	12,860 lbs.

\*Reduction of main boom capacities

AUXILIARY BOOM HEAD	356 lbs.
HOOKBLOCKS and HEADACHE BALLS:	
100 Ton, 8 Sheave	3,012 lbs.+
15 Ton, 1 Sheave	650 lbs.+
7 1/2 Ton Headache Ball	338 lbs.+
10 Ton Headache Ball	560 lbs.+

+Refer to rating plate for actual weight.

When lifting over swingaway and/or jib combinations, deduct total weight of all load handling devices reeved over main boom nose directly from swingaway or jib capacity.

NOTE: All load handling devices and boom attachments are considered part of the load and suitable allowances **MUST BE MADE** for their combined weights. Weights are for Grove furnished equipment.



33 FT. - 58 FT. TELE EXTENSION ON OUTRIGGERS FULLY EXTENDED - 360°

Radius in Feet	33 ft. LENGTH			48 ft. LENGTH			58 ft. LENGTH		
	#0021	#0022	#0023	#0031	#0032	#0033	#0041	#0042	#0043
	2° OFFSET	15° OFFSET	30° OFFSET	2° OFFSET	15° OFFSET	30° OFFSET	2° OFFSET	15° OFFSET	30° OFFSET
25	*24,500 (80)								
30	23,250 (79)	*16,600 (80)		*16,900 (80)			*11,000 (80)		
35	21,100 (77)	15,950 (79.5)		15,600 (79)			10,850 (79.5)		
40	19,300 (75)	14,250 (77.5)	12,000 (80)	13,850 (77)	*11,000 (80)		10,400 (78)		
45	17,900 (72.5)	12,750 (75)	10,950 (78)	12,300 (75)	10,150 (78.5)		10,000 (76)	*8,580 (80)	
50	16,800 (70.5)	11,450 (73)	10,000 (75.5)	11,000 (73)	9,260 (76.5)	*7,890 (80)	9,380 (74.5)	8,040 (78.5)	*6,140 (80)
60	13,450 (66)	9,570 (68.5)	8,510 (71)	9,030 (69)	7,750 (72.5)	6,790 (76)	7,750 (70.5)	6,780 (75)	5,940 (79)
70	10,700 (61.5)	8,080 (64)	7,310 (66.5)	7,510 (65)	6,590 (68.5)	5,880 (72)	6,510 (67)	5,800 (71.5)	5,160 (75.5)
80	8,810 (57)	6,870 (59)	6,320 (61.5)	6,320 (61)	5,640 (64.5)	5,130 (67.5)	5,550 (63)	5,010 (67.5)	4,520 (71.5)
90	7,310 (51.5)	5,900 (54)	5,490 (56.5)	5,380 (56.5)	4,870 (60)	4,490 (63)	4,760 (59.5)	4,350 (63.5)	3,980 (67)
100	6,100 (46)	5,080 (48.5)	4,800 (50.5)	4,610 (52)	4,230 (55)	3,950 (58)	4,110 (55)	3,790 (59)	3,510 (62.5)
110	4,820 (40)	4,380 (42.5)	4,210 (44)	3,970 (47)	3,690 (50)	3,480 (53)	3,560 (50.5)	3,320 (54.5)	3,100 (58)
120	3,230 (33.5)	3,230 (35)	3,230 (36.5)	3,430 (41.5)	3,210 (44.5)	3,090 (47)	3,100 (46)	2,910 (49.5)	2,750 (52.5)
130				2,940 (35.5)	2,810 (38)	2,740 (40.5)	2,700 (41)	2,560 (44.5)	2,440 (47)
140				2,030 (29)	2,030 (31)	2,030 (32.5)	2,340 (35)	2,250 (38.5)	2,180 (40)
150							1,800 (29.5)	1,800 (31.5)	1,800 (32.5)

NOTE: ( ) Boom angles are in degrees.

A6-829-011876A

\*This capacity is based upon maximum boom angle.

#LMI operating code. Refer to LMI manual for instructions.

1. All capacities above the bold line are based on structural strength of boom extension.
2. 33 ft., 48 ft. and 58 ft. boom extension lengths may be used for double or single line lifting service.
3. Rated load is based on loaded main boom angle with reference to horizontal, regardless of main boom length. (Ref. radius is for fully extended boom length only.)

WARNING: Operation of this machine with heavier loads than the capacities listed is strictly prohibited. Machine tipping with boom extension occurs rapidly and without advance warning.

4. Capacities listed are with fully extended outriggers only.
5. BOOM EXTENSION WARNING: For main boom length greater than 96 ft. with 33-58 ft. tele. boom extension in working position, the boom angle must not be less than 30° since loss of stability will occur causing a tipping condition. The boom angle is not restricted for main boom length equal to or less than 96 ft. This warning also applies for boom extension erection purposes.

## 46 FT. - 88 FT. FIXED JIBS ON OUTRIGGERS FULLY EXTENDED - 360°

Main Boom Angle (Deg.)	46 FT. JIB						60 FT. JIB					
	#0071		#0072		#0073		#0074		#0075		#0076	
	5° OFFSET		17° OFFSET		30° OFFSET		5° OFFSET		17° OFFSET		30° OFFSET	
	Rad. Ref. (ft.)*	Cap. lbs.**	Rad. Ref. (ft.)*	Cap. lbs.**	Rad. Ref. (ft.)*	Cap. lbs.**	Rad. Ref. (ft.)*	Cap. lbs.**	Rad. Ref. (ft.)*	Cap. lbs.**	Rad. Ref. (ft.)*	Cap. lbs.**
80	31.3	17,800	41.4	15,100	50.1	10,700	36.4	13,400	48.9	10,300	59.4	7,170
77.5	38.1	16,900	47.8	14,600	56.1	10,200	43.6	12,600	55.8	9,840	66.1	6,720
75	44.8	16,200	54.1	14,100	62.1	9,710	50.7	12,000	62.7	9,400	72.7	6,340
72.5	51.2	15,500	60.2	13,600	67.9	9,280	57.8	11,300	69.4	9,000	79.0	6,010
70	57.8	14,900	66.3	13,200	73.7	8,870	64.7	10,800	76.0	8,630	85.3	5,730
67.5	64.1	13,300	72.2	11,500	79.2	8,510	71.4	10,200	82.4	8,300	91.4	5,480
65	70.3	11,200	78.0	9,940	84.7	8,170	78.1	9,630	88.8	8,000	97.3	5,260
62.5	76.4	9,580	83.7	8,580	89.9	7,860	84.6	8,180	94.8	7,160	103.1	5,060
60	82.4	8,220	89.2	7,440	95.0	6,890	90.9	6,990	100.8	6,200	108.7	4,890
55	93.8	6,150	99.6	5,660	104.7	5,330	103.2	5,170	112.1	4,670	119.1	4,330
50	104.6	4,650	109.3	4,340	113.5	4,140	114.5	3,840	122.6	3,520		
45	114.5	3,540	118.2	3,340	121.4	3,210						

Main Boom Angle (Deg.)	74 FT. JIB						88 FT. JIB					
	#0077		#0078		#0079		#0080		#0081		#0082	
	5° OFFSET		17° OFFSET		30° OFFSET		5° OFFSET		17° OFFSET		30° OFFSET	
	Rad. Ref. (ft.)*	Cap. lbs.**	Rad. Ref. (ft.)*	Cap. lbs.**	Rad. Ref. (ft.)*	Cap. lbs.**	Rad. Ref. (ft.)*	Cap. lbs.**	Rad. Ref. (ft.)*	Cap. lbs.**	Rad. Ref. (ft.)*	Cap. lbs.**
80	39.8	10,300	55.0	7,380	68.8	5,230	44.3	7,960	62.4	5,110	78.8	3,170
77.5	47.8	9,620	62.7	6,920	75.8	4,870	52.7	7,260	70.2	4,670	85.9	2,900
75	55.8	8,960	70.2	6,500	82.5	4,550	60.9	6,620	78.0	4,270	92.9	2,650
72.5	63.5	8,360	77.6	6,120	89.2	4,280	69.1	6,050	85.6	3,910	99.7	2,430
70	71.2	7,820	84.8	5,780	95.8	4,030	77.1	5,530	93.1	3,570	106.3	2,220
67.5	78.8	7,330	92.0	5,460	102.1	3,820	84.9	5,050	100.3	3,250	112.8	2,040
65	86.2	6,880	98.9	5,170	108.2	3,630	92.7	4,620	107.4	2,950	119.0	1,880
62.5	93.4	6,470	105.7	4,910	114.1	3,460	100.2	4,230	114.3	2,660	124.9	1,730
60	100.5	5,970	112.2	4,670	119.8	3,300	107.6	3,870	121.0	2,400		
55	114.1	4,330	124.7	3,840			121.7	3,240				

#LMI operating codes. Refer to LMI manual for instructions.

A6-829-004518C

\*Reference radius refers to fully extended boom and appropriate jib length.

\*\*Capacities at loaded main boom angle.

1. All capacities above the bold line are based on structural strength of jib.
2. May be used for double or single line lifting service. Double line lifting service is required when unit is equipped with Krueger LMI.
3. Rated load is based on loaded main boom angle with reference to horizontal, regardless of main boom length. (Ref. radius is for fully extended boom and power fly extended 114 ft. boom length only.) The LMI system will give an accurate radius indication for this condition only.)
4. **WARNING:** Operation of this machine with heavier loads than the capacities listed is strictly prohibited. Machine tipping with every jib occurs rapidly and without advance warning.
5. **WARNING:** The Krueger LMI will not compensate for reeving/rigging accessories on the main boom nose or auxiliary boom nose when programmed to monitor the jib. Remove all reeving/rigging accessories from main boom when using jib.
6. **46 FT. JIB WARNING:** With 46 ft. jib in working position, the boom angle must not be less than 30° since loss of stability will occur causing a tipping condition.  
**60 FT. JIB WARNING:** With 60 ft. jib in working position, the boom angle must not be less than 35° since loss of stability will occur causing a tipping condition.  
**74 FT. JIB WARNING:** With 74 ft. jib in working position, the boom angle must not be less than 40° since loss of stability will occur causing a tipping condition.  
**88 FT. JIB WARNING:** With 88 ft. jib in working position, the boom angle must not be less than 40° since loss of stability will occur causing a tipping condition.
7. **JIB ERECTION NOTES:**
  - A. Maximum length of main boom including extended fly for purpose of erecting jib below 30° main boom angle is:
    - 46 ft. Jib - 102 ft.
    - 60 ft. Jib - 99 ft.
    - 74 ft. Jib - 94 ft.
    - 88 ft. Jib - 88 ft.
8. Capacities listed are with fully extended outriggers only.

**WORKING RANGE DIAGRAM**  
 (BOOM DEFLECTION NOT SHOWN) D6-829-007869

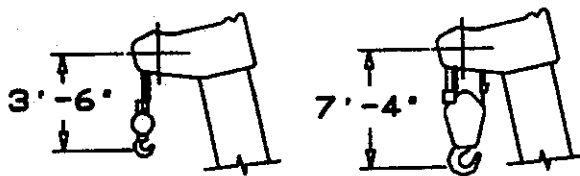
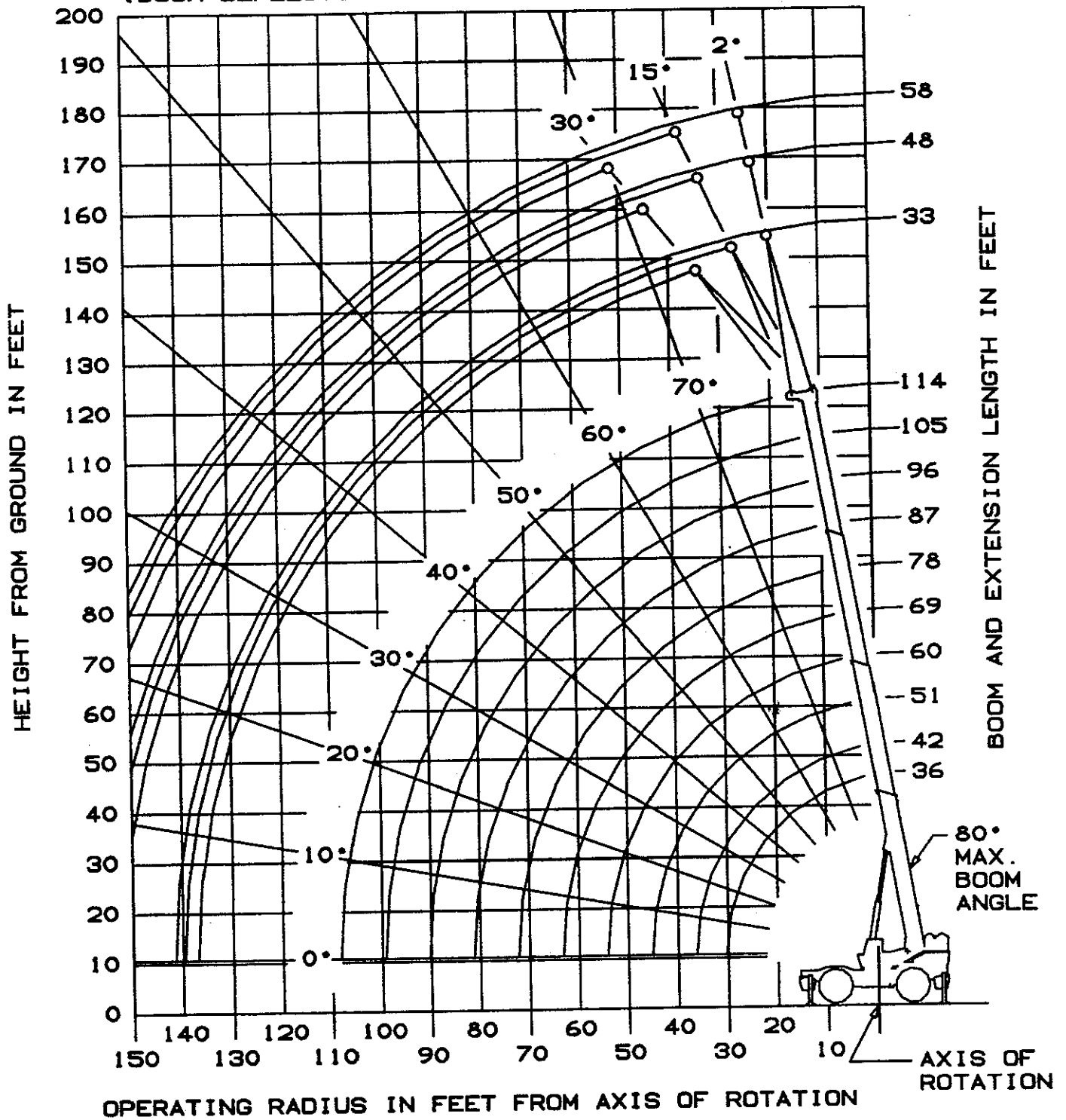

**DIMENSIONS ARE FOR LARGEST GROVE FURNISHED HOOK BLOCK AND HEADACHE BALL WITH ANTI-TWO BLOCK ACTIVATED.**

# WORKING RANGE DIAGRAM

(BOOM DEFLECTION NOT SHOWN)

D6-829-007877

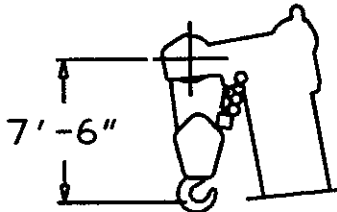
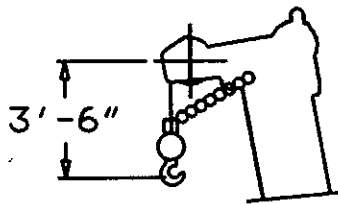
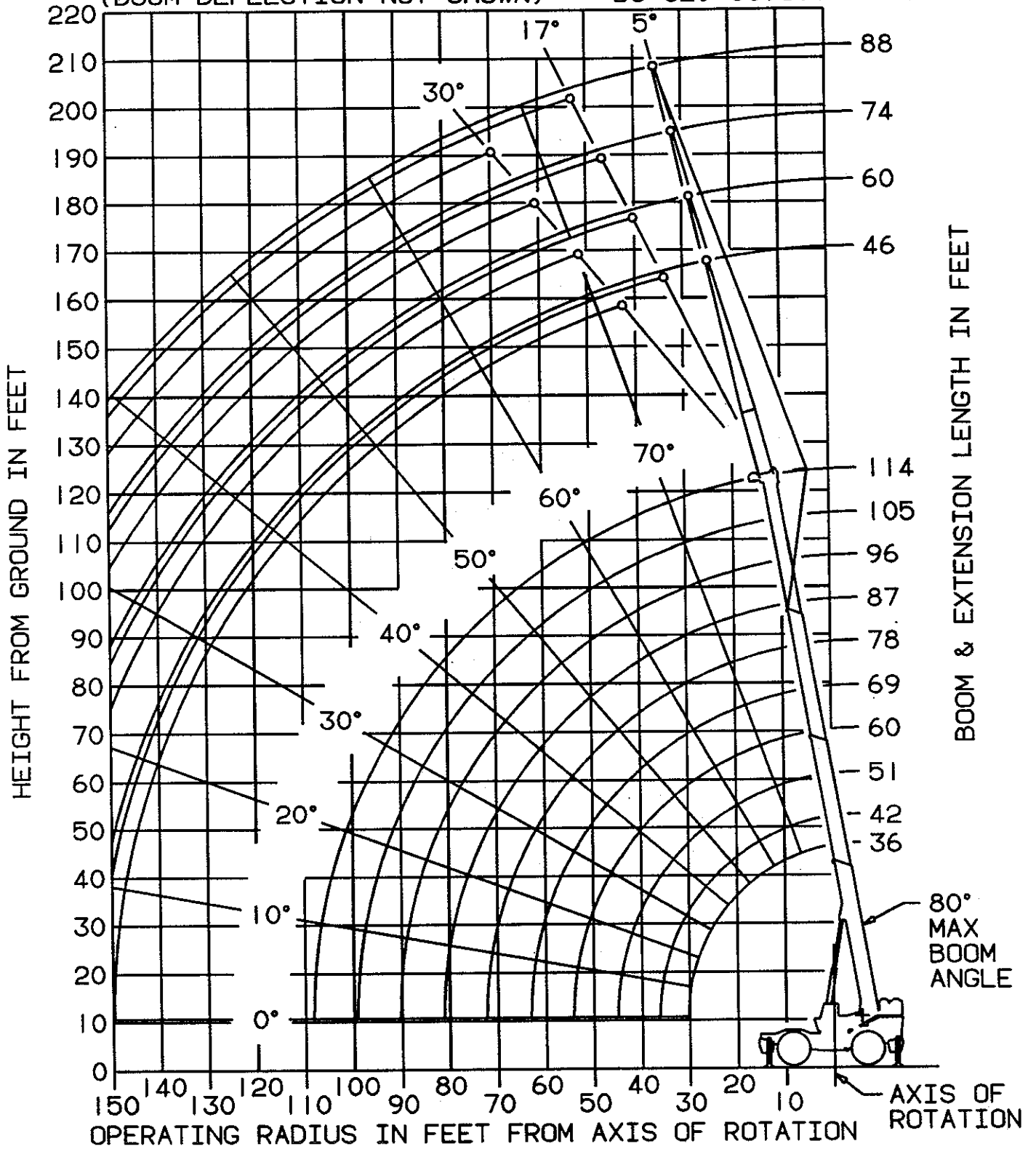

DIMENSIONS ARE FOR LARGEST GROVE FURNISHED HOOK BLOCK AND HEADACHE BALL, WITH ANTI-TWO BLOCK ACTIVATED.

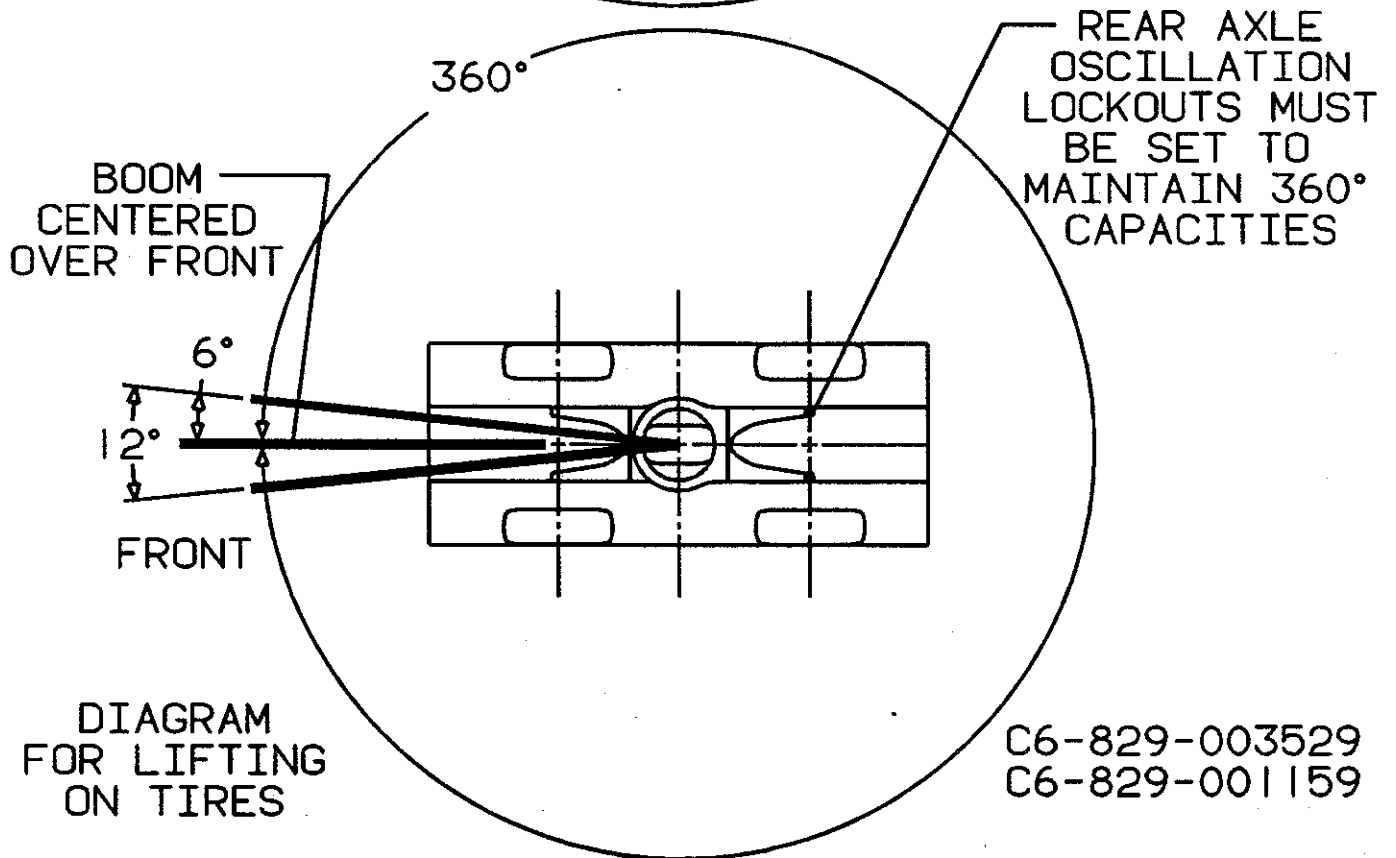
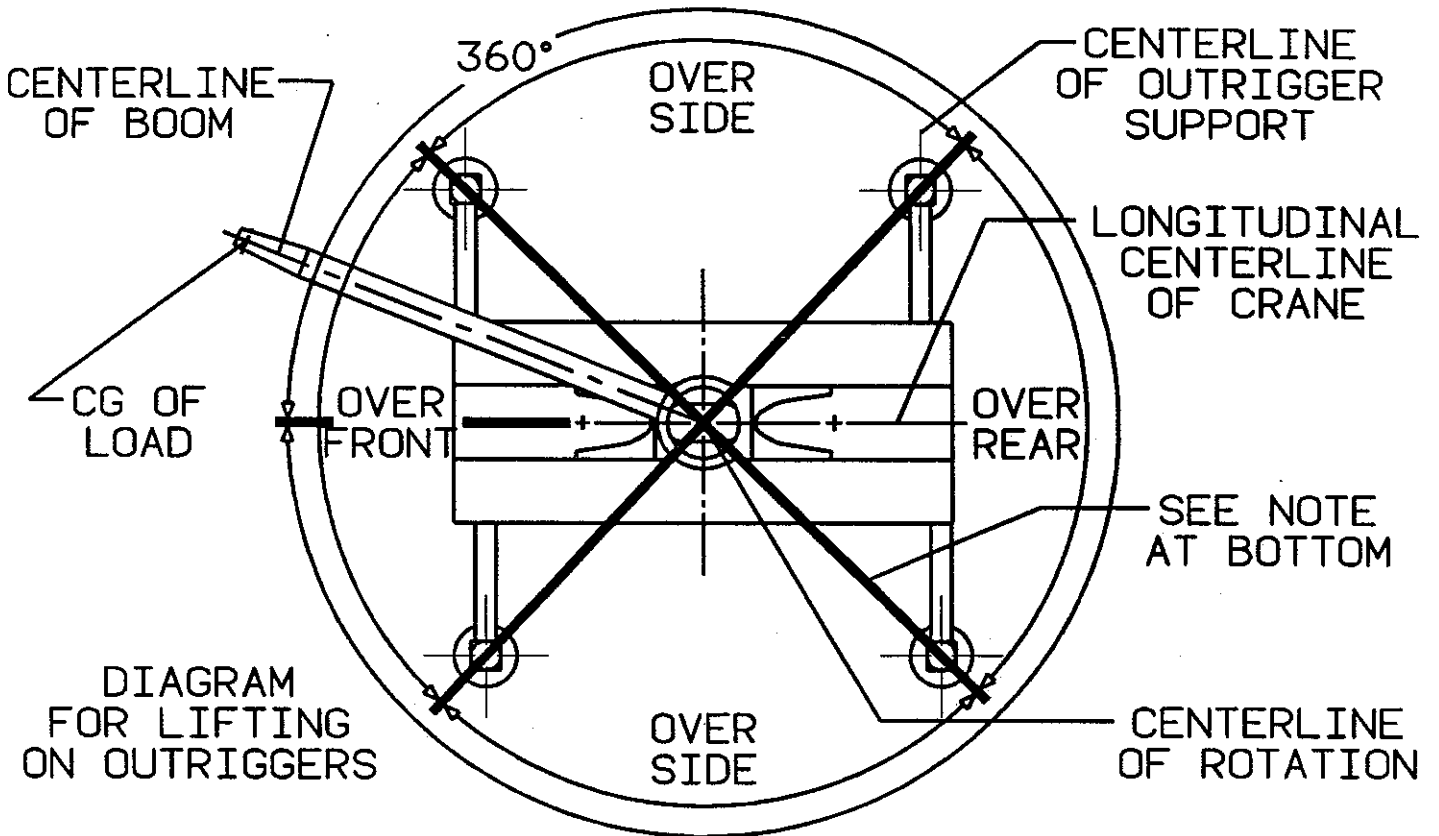

C6-829-003529  
C6-829-001159

BOLD LINES DETERMINE THE LIMITING POSITION OF ANY LOAD FOR OPERATION WITHIN WORKING AREAS INDICATED

WORKING AREA DIAGRAM

# ZERO DEGREE BOOM ANGLE CHARTS

## ON OUTRIGGERS FULLY EXTENDED - 360°

Boom Angle	Main Boom Length in Feet									
	36	42	51	60	69	78	87	96	105	114
0°	31,400 (30.2)	25,200 (36.3)	18,750 (45.3)	14,200 (54.3)	10,850 (63.3)	8,300 (72.3)	6,250 (81.3)	4,570 (90.3)	3,180 (99.3)	2,060 (107.8)

## ON RUBBER 33.25 x 35 TIRES

### STATIONARY CAPACITY - DEFINED ARC OVER FRONT

Boom Angle	Main Boom Length in Feet							
	36	42	51	60	69	78	87	96
0°	31,400 (30.2)	25,200 (36.3)	17,150 (45.3)	11,800 (54.3)	8,220 (63.3)	5,650 (72.3)	3,710 (81.3)	2,210 (90.3)

### STATIONARY CAPACITY - 360°

Boom Angle	Main Boom Length in Feet			
	36	42	51	60
0°	14,150 (30.2)	9,520 (36.3)	5,170 (45.3)	2,400 (54.3)

### PICK & CARRY CAPACITIES - UP TO 2.5 MPH BOOM CENTERED OVER FRONT

Boom Angle	Main Boom Length in Feet							
	36	42	51	60	69	78	87	96
0°	26,950 (30.2)	21,300 (36.3)	15,300 (45.3)	11,100 (54.3)	7,980 (63.3)	5,560 (72.3)	3,630 (81.3)	2,070 (90.3)

A6-829-011877

Note:( ) Reference radii in feet.

Refer to in-cab load chart for notes.