



Smart Technology. Delivered.

Command Pro
Engineered Systems
User Manual

	<p>WARNING Read all safety rules and warnings before installing and operating this system.</p>
--	---

REVISION HISTORY

Revision	Date	Changes
1.0		Initial Release
2.0	04/2014	Updated Styles Revised Content
2.1	06/2014	Updated Mounting Hole Dimensions for 21R14A Updated Warning Style

TABLE OF CONTENTS

Revision History.....	2
Table of Contents.....	3
1 Important Safety Notice	4
2 Command Pro Receivers FCC Compliance Statement.....	5
3 Safety Rules.....	6
3.1 Personal Safety	6
3.2 Care.....	6
4 Introduction.....	7
4.1 Purpose.....	7
4.2 Scope.....	7
4.3 Important Safety Rules	7
4.4 Carrying Strap for 'Belly Box' Controllers	7
5 Operations	10
5.1 How the System Works	10
5.2 Transmitter Operation and Features	12
5.3 Wireless Operation.....	12
5.4 Pendant Operation.....	12
5.5 Commands.....	12
5.6 Status Indicators	14
6 Installation.....	15
6.1 General	15
6.2 Locating the Equipment	15
6.3 Installation Wiring.....	17
6.4 Installation Procedure -21R14A Receiver.....	17
6.5 Installation Procedure -21R22	21
6.6 Installation Procedure – SAFE-T-RANGE (21R22CR)	25
6.7 Installation Procedure – 22R08A	27
7 Maintenance & Troubleshooting.....	32
7.1 Monthly Inspection	32
7.2 Installation Troubleshooting.....	32
7.3 Transmitter Troubleshooting.....	32
7.4 Transmitter Spare Parts List.....	36
7.5 Receiver Troubleshooting.....	37
7.6 Receiver Testing	37
7.7 Receiver Spare Parts List.....	39
8 Warranty Statement for Command Pro 21 and 22 Series.....	40
8.1 Transmitters.....	40
8.2 Receivers and Accessories	40
8.3 General Terms of Warranty.....	40
8.4 Service.....	40
Appendix I: Transmitter Specifications	41
Certifications 42	
Appendix II: Receiver Specifications.....	43
Certifications 44	
Support.....	45

1 IMPORTANT SAFETY NOTICE

	WARNING
	<p>The use of unapproved components or accessories in the systems sold by Laird and its subsidiaries is strictly prohibited. Unapproved components are defined as any component not inspected and sold by Laird. This also includes any component modified from its intended use and/or any component exhibiting observable damage or defect. Use of non-conforming parts, assemblies and accessories may lead to injury or death.</p>

	WARNING
	<p>The remote control system you have purchased is designed to stop in a safe mode under a variety of conditions. Some examples of these conditions are: excessive radio signal interference, loss of battery or electrical power, failure of certain components and operation beyond signal range and others. Although Laird and its subsidiaries does not specify the position of the operator when controlling the equipment we are aware that some users are instructed and trained by their employer to ride the equipment in a safe manner. It is imperative that you are prepared for an unplanned stop of the equipment at any time and do not place yourself or others in a position where this situation may cause you to fall from the equipment. Failure to use caution may lead to injury or death.</p>

2 COMMAND PRO RECEIVERS FCC COMPLIANCE STATEMENT

COMMAND PRO® series receivers have been tested and found to comply with the limits for a Class B digital device, pursuant to Part 15 of the FCC Rules. These limits are designed to provide reasonable protection against harmful interference in a residential installation.

This equipment generates, uses, and can radiate radio-frequency energy, and if not installed and used in accordance with the user manual, may cause harmful interference to radio communications. However, **there is no guarantee that harmful interference will not occur in a particular installation.**

If this equipment does cause harmful interference to radio or television reception, which can be determined by switching this equipment on and off, the user is encouraged to try to correct the interference by one or more of the following measures:

- Reorient or relocate the receiving antenna connected to the device that is receiving the interference.
- Increase the separation between Laird equipment and the equipment receiving the interference.
- Consult our factory or one of our Service Representatives for additional help.

Responsible Party:

Laird, Inc.

1916 W. Mission Rd.

Escondido, CA 92029

Phone: 800-328-5570

Fax: 760-737-7810

3 SAFETY RULES

	WARNING
	Read all instructions. Failure to follow these rules can result in serious personal injury.

- GROUND THE RECEIVER CASE. In order to ensure safety of the system, firmly connect the receiver case to earth ground.
- PROVIDE A SAFETY CUTOFF SWITCH. If maintenance is required, disconnect the radio from power to prevent accidental activation.
- USE PROPER WIRING. Loose or frayed wires can cause accidental machinery activation.
- DO NOT INSTALL IN HOT AREAS. This apparatus can be damaged by heat in excess of 160° F.
- DO NOT INSTALL IN HIGH VIBRATION AREAS. The life of this apparatus might be shortened through long exposure to intense shaking or vibration.

3.1 Personal Safety

- MAKE SURE MACHINERY IS CLEAR BEFORE OPERATING. Do not activate the remote system unless it is safe to do so.
- SWITCH OFF THE RECEIVER POWER BEFORE WORKING ON MACHINERY. Always disconnect the remote system power before performing any maintenance to prevent accidental machine operation.

3.2 Care

- KEEP DRY. If water or other liquids get inside the device, immediately dry the unit.
- KEEP ANTENNAS CLEAN. Keep antenna connections clean and free of corrosion.

Note: Throughout this manual, other safety rules appear under the following heading:

	WARNING
	Failure to follow these rules can result in serious personal injury.

4 INTRODUCTION

4.1 Purpose

This manual provides information on the safe installation and operation of the Laird Command Pro® wireless control systems. Information is also included on the maintenance and repair of the Command Pro systems.

4.2 Scope

Information is included on all types of Laird transmitters and receivers used in industrial applications. Refer to the detailed information contained in each section for your particular equipment.

The transmitters covered in this manual contain enhanced features that expand the types of applications for the systems.

Many new features have been added, but most changes are transparent to the user. If you are already familiar with Laird transmitters, you are encouraged to read the section on operating the transmitters, where there is information about the latest changes in operation.

To help you identify your system, Figure 1 and Figure 2 provide a reference for the transmitters and receivers covered in this manual. Review the Configuration Sheet that came with your equipment for details on the types of switches and the labels used on your equipment.

4.3 Important Safety Rules

Using wireless control systems with heavy industrial equipment can improve the safety of the equipment.

It is important to adhere to the safety rules presented throughout this manual, especially during installation, in order to achieve the safest operating system possible.

4.4 Carrying Strap for 'Belly Box' Controllers

A Shoulder Carrying Strap (Part #600057) is supplied with the 21T34A, T44A, T54A, and T74A 'Belly Box'-style controllers which greatly enhances operator comfort. Operators of these 'Belly Box'-style controllers are required to use this approved carrying strap with the controller attached at all times.

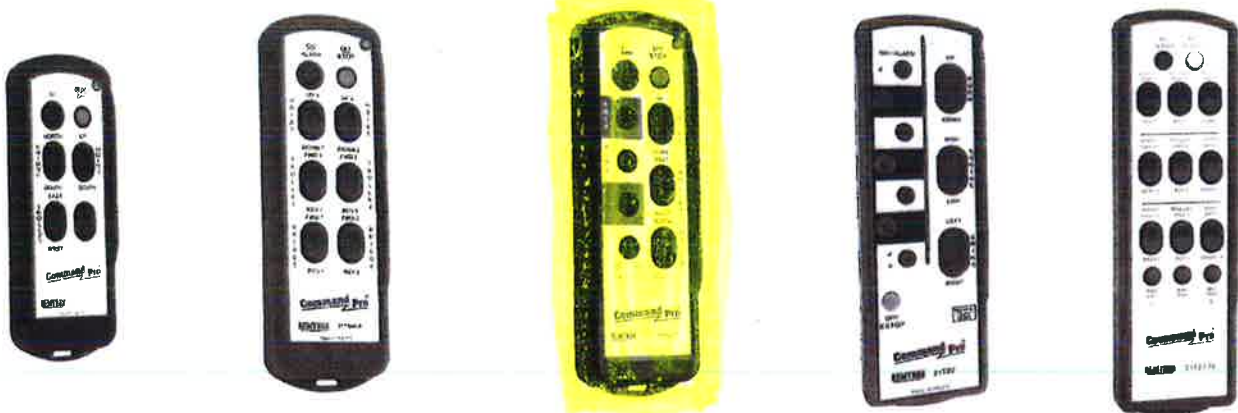

21T10(A)

21T14(A)

21T18(A)

21T20

21



21T34A
Stepped Lever Control
Transmitter



21T44A
Proportional Lever
Control
Transmitter

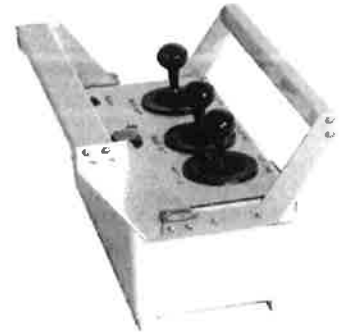

21T54A
Joystick Control
Transmitter

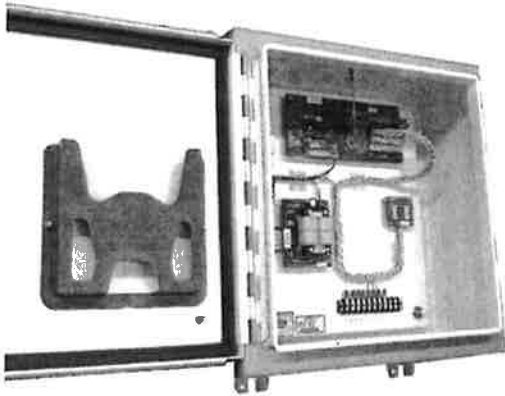

T08C
Remotely Operated
Transmitter



21T74A
Custom Lever Control
Transmitter

Figure 1: Laird Command Pro Engineered Systems Transmitters

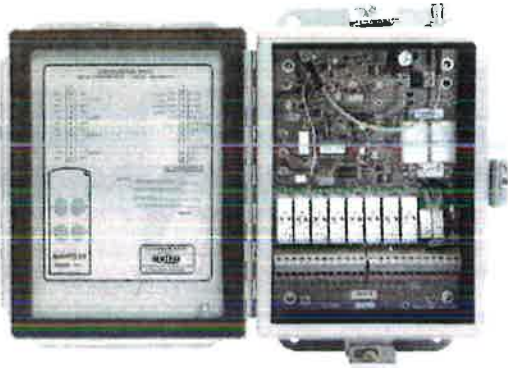

22R08A
8 Function Receiver

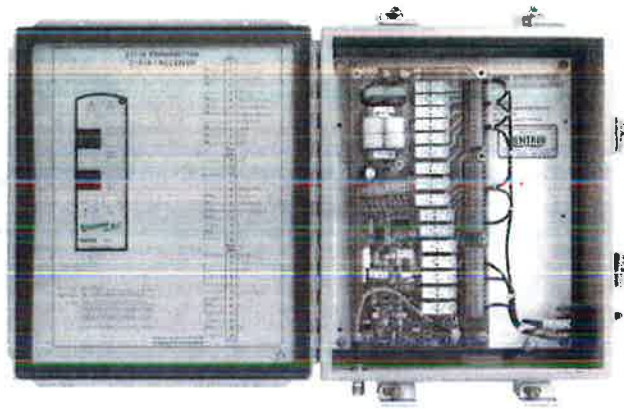

21R14A
14 Function Receiver

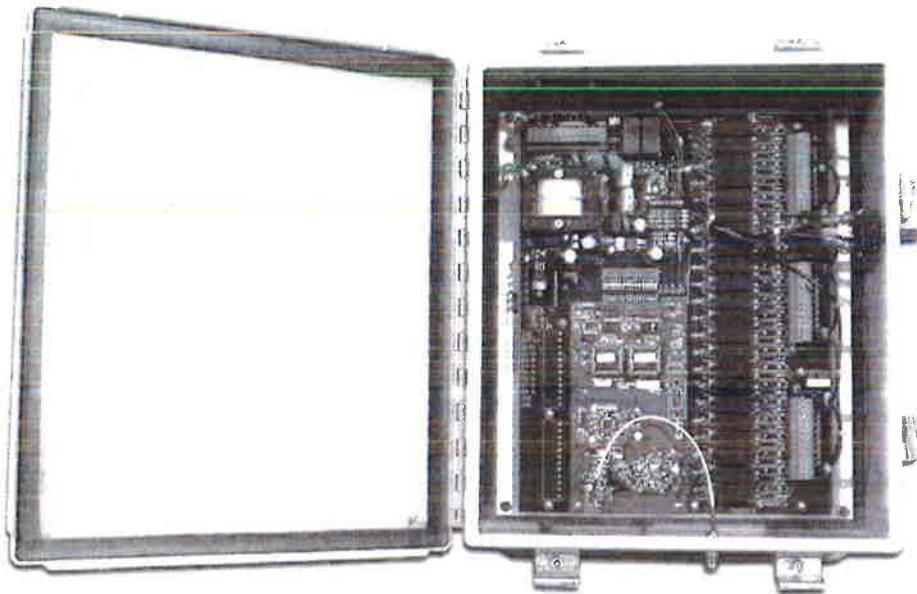

21R22
22 to 66 Function Receiver

Figure 2: Laird Command Pro Engineered Systems Receivers

5 OPERATIONS

Laird Command Pro Wireless Control Systems are designed to control industrial machinery. These rugged controls are built to survive the wear and tear of life in factories, mills, and foundries.

These systems comply with operation requirements under Part 15 of the FCC Rules and Regulations. This means that neither the operator nor the company need apply or register for a license to operate this equipment.

The basic system consists of a transmitter and a receiver. The transmitter sends commands to the receiver through radio waves in the 900 MHz band. Receivers operate at 120 VAC 50/60 Hz power. Operation from other power sources is also available.

5.1 How the System Works

5.1.1 Frequency

Laird Command Pro equipment operates in the 902 to 928 Megahertz (MHz) frequency band. A wavelength at our frequency is 12.9 inches.

Like light, 900 MHz radio signals pass through glass and plastics, and reflect off of walls, buildings, and metal structures. Unlike light, 900 MHz radio signals penetrate all plastics including those opaque in color, as well as thin-gauge steel, dry wood, dry concrete, plasterboard, fog, and rain. However, the signal will not readily pass through trees, earth, water, people, aluminium, copper, and some window tints.

5.1.2 Range and Antenna Coverage

Antennas convert radio signals into radio waves, and convert radio waves back into radio signals. They can send and receive in all directions or in a single direction, depending on their design.

An omnidirectional antenna is like a light bulb, and a directional antenna is like a flashlight. Metal objects reflect radio waves, just as a mirror next to a light bulb will reflect light. Metal objects near an antenna alter the intended pattern of an antenna by either shading or reflecting signals.

Our standard antennas are omnidirectional; they 'see' equally well in all directions. We have other antennas that will 'see' further in one direction for special applications.

5.1.3 License-Free Channels

The 902 to 928 MHz spectrum accommodates many license-free users and is set aside by the FCC as an ISM Band (Industrial, Scientific, and Medical). We have the ability to change frequencies in this band and have 81 different channels that we can assign to the transmitter and receiver. The actual frequency is coded into the receiver and transmitter at the factory but may be changed to one of the other 80 channels in the field if desired.

Other devices in this band include wireless phones, computer data links, and inventory equipment. As a condition of using this band, products must accept and handle interference from other users.

The 900 MHz band works well for most users, and not being burdened with licensing regulations is desirable. The FCC has allowed 50,000 microvolts per meter field strength on this band, which is 250 times higher than other unlicensed frequencies below the band. This allows our systems to operate very reliably in the presence of other signals.

5.1.4 Command Format

This device uses packet-mode, Frequency Modulation (FM) to carry commands in packet form from our transmitter to our receiver.

To reduce battery drain, the transmitter transmits for a hundredth of a second, which is long enough to send one packet to our receiver at a repetition rate of 16 or 4 times per second.

The rate varies: 16 times per second for three times when sending a command and four times per second when there is no change in commands and the transmitter is still on. Any time a lever or switch activates, we send all control settings three times at the 16-per-second rate and then return to the slower rate of 4 times per second.

Our receiver uses the slower rate for maintaining transmitter timing and provides for a maintained link where one is used. The only exception to this is the 'STOP' switch, which transmits at 16 times per second as long as it is depressed. In addition to lever and switch positions, each packet contains a unique address and CRC check sum (described in the next section).

5.1.5 Safety

Safety and loss of control prevention are very important issues at Laird. We use a unique identification (ID) code for each user. There are provisions in our system for 65,535 individual codes.

Each transmission includes a CRC check sum, which is a polynomial created by factoring all of the previous bits transmitted. Once the receiver receives a valid start command from the transmitter, the receiver tracks the time of the transmitter and ignores all other transmissions that do not fall within the expected time frame of the transmitter.

Maintained link systems must receive at least one valid transmission each second in order to allow the remote controlled equipment to function. The receiver provides a loss-of-signal control output that safely shuts down the equipment if a loss of signal occurs.

The receiver will not allow equipment restart under its control after a loss of signal until a valid system start command is received from the transmitter. This prevents an unintended start-up from occurring if the transmitter returns within range of the receiver and is still operating.

The transmitters also check the position of all controls upon start-up. The transmitter does not issue a start command if any of the controls are pressed at the time the start command begins. Exceptions for lights, horn, bell, or other user functions that do not place machinery in motion can be mapped into our control logic upon request.

FM systems also have a capture effect, where the strongest signal captures the receiver, which rejects the weaker signal. The operator is seldom more than 300 feet from the controlled machine. Therefore, the transmitter is the strongest signal present unless other equipment on this band is allowed to operate within 1000 feet of the location of the receiver.

5.1.6 Carrying Strap for 'Belly Box' Controllers

A Shoulder Carrying Strap (Part # 600057) is supplied with the 21T34A, 21T44A, 21T54A, and 21T74A 'Belly Box'-style controllers which greatly enhances operator comfort. Operators of these 'Belly Box'-style controllers are required to use this approved carrying strap with the controller attached at all times.

5.2 Transmitter Operation and Features

	WARNING
	Do not operate the system until you are familiar with radio-controlled operation. If you are not familiar with radio-controlled operation, contact your supervisor before attempting to use the radio control system.

IMPORTANT: To stop the system in an emergency, press and hold the OFF/STOP button. Pressing and holding this button stops all functions.

5.3 Wireless Operation

1. If the transmitter the 'belly box' type, operators are required to use the supplied Shoulder Carrying Strap with the controller attached at all times.
2. If the transmitter is equipped with pendant capability, verify that the pendant cable is not attached before switching on the transmitter.
3. Press and release the ON/ALARM button. Verify that the Status LED starts flashing at a low rate. If equipped, the Alarm function sounds.
4. Press the required switches to operate the desired function. Note that more than one function may be controlled at any time.
5. To stop sending any command, release the switch.
6. To switch the transmitter off, press the OFF/STOP button. (Note that the transmitter switches itself off if no commands send for a predetermined time and if Auto Off is enabled).
7. If equipped with a maintained OFF/STOP switch, the transmitter continues transmitting the OFF/STOP signal for a preset time after the OFF/STOP switch is pressed to the maintained position. Resetting the switch immediately switches the transmitter off.

5.4 Pendant Operation

1. Connect the pendant cable to the transmitter and receiver. If the transmitter was ON in the normal mode, it will stop RF transmissions and send commands only through the pendant cable. The transmitter will not resume RF transmissions until the pendant cable is removed and the transmitter is momentarily switched off.
2. The remainder of the operation is the same as the wireless operation described above.

5.5 Commands

5.5.1 Command Switches

The command switches are labeled according to their function.

- If two commands that conflict with each other are attempted, in most cases no function results. In the case of ON/OFF functions, OFF predominates.
- If more than one speed command is sent for the same function, the lower speed predominates.
- Maintained On or Off functions require separate commands for ON and OFF.

ON/ALARM: This button switches the transmitter on and puts the system in the active mode. It also sends an ALARM command to the receiver while the switch is depressed. The transmitter remains active until the OFF/STOP button is pressed or the transmitter switches itself off (see Auto Off).

OFF/STOP: While depressed, this button sends a STOP command to the receiver. The transmitter does not need to be actively 'ON' to send this command. When this switch is released, the transmitter switches off.

AUTO OFF: The transmitter switches itself off if no commands are sent for a predetermined time. Normally this time is set to 15 minutes, but it may be programmed from 0 to 60 minutes, or disabled using a RAC16 Series Programmer (01 to 60 = minutes, 00 = disabled).

Levers (21T34A/44A/74A) / Joysticks (21T54A): When in the neutral (center) position, no commands send. When a paddle moves from the neutral position, a command generates proportional to the amount of movement (the further the lever is pushed, the faster the movement is commanded).

Push-to-Operate (PTO) Switch (Optional): The PTO or 'Dead Man Switch' is a safety device. The transmitters are normally programmed so that the switch that activates this function must be depressed before any motor or other critical function can operate (consult the Configuration Sheet if this switch has an alternate use in your system).

First-Come First-Serve (FCFS) (Optional): The First-Come First-Serve option allows use of multiple transmitters with one receiver, one at a time. The receiver scans a preset list of ID Codes. When a valid signal is received, the receiver stops scanning and responds only to that transmitter's signal. When the signal is no longer being received (that is, the transmitter has been switched off or is out of range), the receiver again scans until another valid signal is received.

Pitch-and-Catch (Optional): Pitch-and-Catch is similar to First-Come First-Serve but adds the safety requirement that the operator in control must release or 'pitch' the control before another operator may assume control. It also allows control transfer from one operator to another without pausing operation. Once the transmitter has taken control of the receiver, the pitch button is the only way to release control of the receiver so that other transmitters can take control. Once the receiver receives a valid pitch command, the receiver then looks for the next programmed ID code. A Catch is made when the ID code from the next transmitter is recognized. If a catch is not made within a pre-set time period, the receiver will revert to First-Come First-Serve until a valid ID code is recognized. Any switch can be programmed as the pitch button.

Note: If a transmitter malfunctions after the receiver has taken control, the only way to release the receiver is to cycle power to the receiver.

A- B Switch (Optional): Selector switches can be provided to control more than one similar function with the same controls (i.e. controlling trolley/hoist A, trolley/hoist B, or both A and B simultaneously). On the handheld transmitters, a single pushbutton cycles between A, B, Both, and OFF each time the button is pressed. LED indicators show the control status.

Key Switch (Optional): The key switch option can prevent the use of the transmitter by unauthorized personnel. The key switch is electrically connected between the battery and the electronics so that all power is removed when the switch is in the OFF position.

Note: Once power is applied, the red LED illuminates and the transmitter performs a self-test procedure lasting approximately three seconds. The transmitter may be switched to 'ON'. Under standard operating conditions, the LED flashes green once when the transmitter switches to 'ON'.

Magnet Control (Optional): An additional safety feature is built into systems that use a lifting magnet. The two-button design uses one button labeled MAG LIFT (or LIFT) and one button labeled MAG DROP (or DROP). Pressing the LIFT button energizes the magnet. Pressing LIFT and DROP at the same time de-energizes the magnet and drops the load.

A time-delay is built into the circuit, so the buttons must be held for nearly one second before the magnetic controls activate. An additional switch may be provided for fanning or dribbling the load. Pressing the button labeled FAN or MAG FAN while pressing MAG LIFT activates the fan drop function. Again, a time-delay is built into the circuit, so these buttons must be held down for nearly one second before the magnetic controls activate.

Multiple Receivers Controlled by Multiple Transmitters Option: One transmitter can control a maximum of six receivers with a rotary selector switch. A rotary switch is often used to select a particular hoist/trolley A/both/B. It can also be used for crane select, i.e. East/West.

5.6 Status Indicators

5.6.1 Status LED

The status LED indicates the transmitter operation. When the transmitter is operating normally, the LED indicator emits short flashes at a low rate when no commands activate, and at a higher rate when a command activates. Some transmitters use a red LED only. Others use a multicolored LED that flashes GREEN when no problems are present and changes to RED when problems are encountered. See Status Chart below.

Table 1: Transmitter Status Chart

LED Indication	Possible Cause
LED is off.	Transmitter is off – switch transmitter ON. Batteries are dead – replace batteries. Transmitter failure – call for service.
LED flashes at low rate.	Transmitter is operating in a normal mode.
LED flashes at high rate.	Command Switch is pressed.
LED flashes Red/Green ('A' series only).	Batteries getting low. Change batteries at the next convenient opportunity.
LED flashes on-off at a slow rate (½ second on and ½ second off).	Batteries getting low. Change batteries at the next convenient opportunity.
LED remains on continuously (LED might flicker slightly).	A switch was activated at the time the transmitter was switched on, or a general failure occurred that requires factory service. Ensure no other switches are pressed while attempting to switch the transmitter on.
LED will not light when ON/OFF button is pushed.	Replace batteries. If this does not correct the problem, the transmitter must be repaired.

5.6.2 Function Select LEDs

Two LEDs are used on some transmitters to indicate which control functions are active (such as hoist trolley A or hoist trolley B. These are commonly used with pilot relays). When both are illuminated, both controls are active. When both LEDs go out, neither control is active.

6 INSTALLATION

6.1 General

Check all the components to confirm that they are the components you ordered for your system and that they are in good condition. If any components are missing, or if any are not in good condition, contact Laird.

	WARNING
	READ ALL INSTRUCTIONS. Failure to follow the SAFETY RULES can result in serious personal injury. Before starting this installation, ensure that the crane power has been disconnected and that all applicable safety precautions are followed.

6.2 Locating the Equipment

6.2.1 Antenna Location

The antenna is one of the most important components of a radio receiving system. Proper placement of the receiver antenna ensures reliable operation under the most severe conditions. A direct 'line-of-sight' path between the transmitter and receiver antenna provides best performance (refer to Figure 3).

Controlled range systems require a special flat panel antenna. Refer to [Installation Procedure - SAFE-T-RANGE \(21R22CR\)](#) for special considerations for the antenna used with that system.

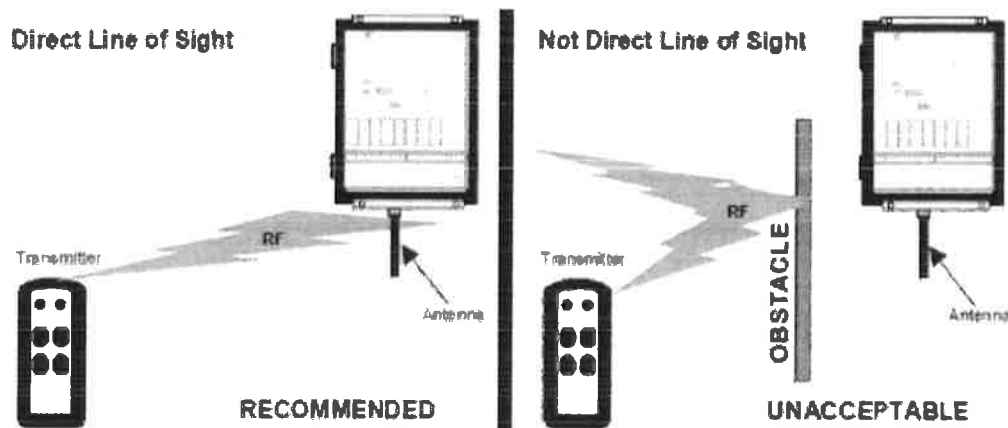

Figure 3: Transmitter / Receiver Communication

In most cases, the antenna may be mounted directly on the receiver cabinet. In determining the mounting location, consider the following items:

- Mount the antenna vertically.
- For optimum performance, give the antenna itself a minimum of eight (8) inches clearance in all directions, excluding the wall or plate to which the receiver cabinet is mounted (refer to Figure 4).
- If the receiver cabinet location cannot provide this clearance and the antenna must be mounted at a remote location, the Laird Remote Antenna Mounting Kit should be used. See [Receiver Spare Parts List](#) or call Laird for more information.

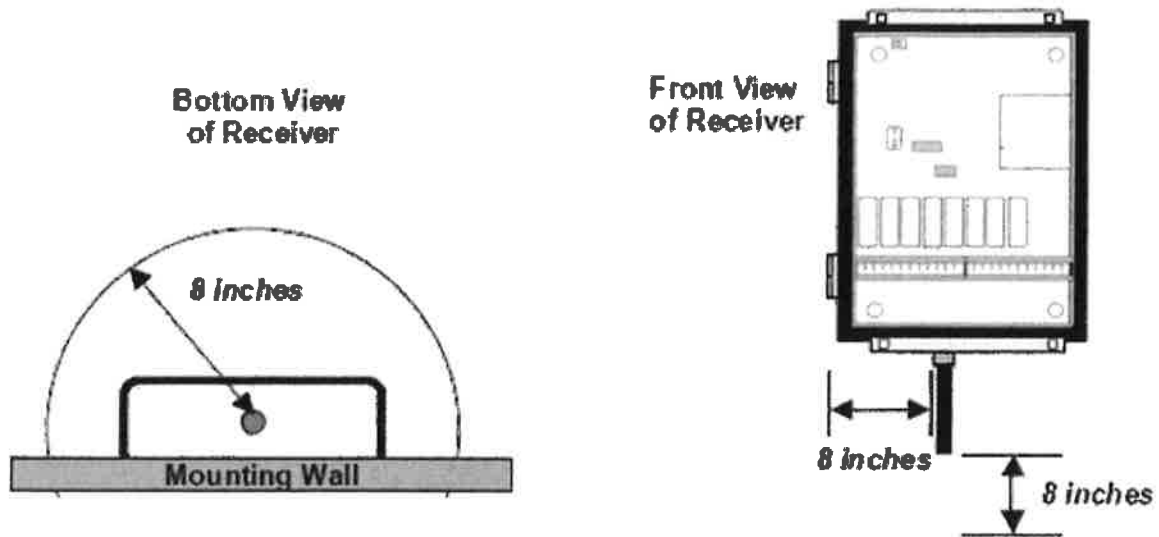

Figure 4: Antenna Clearance

6.2.2 Receiver Location

To ensure safe and reliable system operation, the following items must be considered when selecting a location for mounting the receiver:

- Install the receiver in an environment where the ambient temperature during operation does not drop below -20°F (-28°C) or rise above $+160^{\circ}\text{F}$ ($+71^{\circ}\text{C}$).
- All connections to the receiver enclosure must be watertight.
- Avoid mounting the receiver enclosure on a surface where excessive vibration or shock is present.
- For easy access to wiring and for service, provide sufficient room to open the enclosure door.
- To ensure that the receiver enclosure is electrically at earth ground, remove all paint from the mounting-hole surfaces (refer to Figure 5).

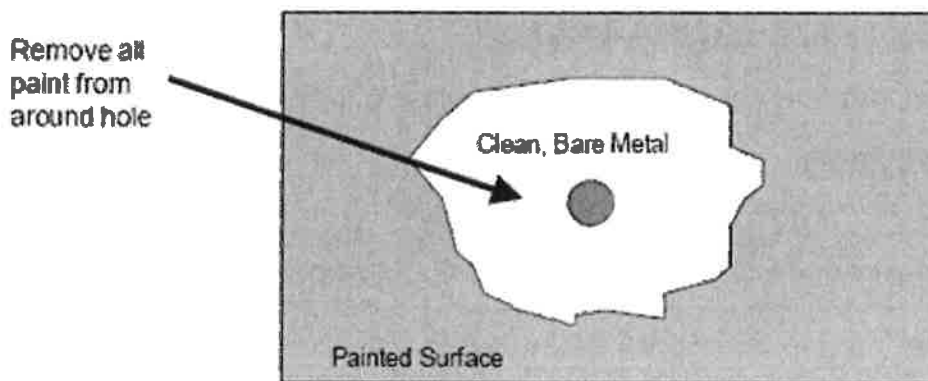

Figure 5: Mounting-Hole Paint Removal

- Mount the receiver enclosure securely using appropriate locking-type hardware. This also assists in properly grounding the receiver enclosure to the mounting surface.

6.3 Installation Wiring

Referring to the configuration sheet provided with the receiver (usually located within the receiver door), dress the receiver output relay wiring and the control switch wiring along the inside wall of the enclosure. This allows for easy troubleshooting and maintenance.

6.3.1 Receiver Power

Laird receivers are normally pre-wired for the most widely used control systems. Specific installations may require rewiring the relay 'commons'. When connecting the Laird receiver assembly to a power source that has large amounts of interference (noise) generated by motors and/or contactors, use noise suppression devices (snubbers) to prevent noise from triggering the receiver's safety shut-down programming.

Never use the receiver case as a ground for other electrical equipment.

6.3.2 Relay Outputs

Limit the load current applied to the output relay bank 'common' to a maximum of 10 amps.

	CAUTION
	Connection to equipment or contractors with higher voltage or current requirements requires an intermediate relay.

6.3.3 Output Snubbers

Snubbers are needed to suppress the noise generated from arcing relay contacts. When a contactor opens, the contactor coil produces a large voltage potential much like automotive ignition systems. When the points open on automotive ignition systems, the coil sends a large voltage to the distributor which jumps across (arcing) the spark plug. The result is a large amount of noise generating in the system.

- A snubber is a device designed to reduce arcing (noise). Laird uses a resistor capacitor combination to accomplish this function. To prevent noise entering the receiver, it is recommended that all contactors have snubbers installed directly across the coils. If more snubbers are needed, See [Receiver Spare Parts List](#) or call Laird's Service Department at 800-328-5570.

6.4 Installation Procedure -21R14A Receiver

Refer to Figure 6 and Figure 7.

6.4.1 Power/Control Wiring

The transfer switch is wired so that the crane's Main Line Contactor (MLC) is controlled by the radio MLC relay when it is in the radio position and by the pendant controls when the switch is in the pendant position. Refer to Figure 7 (21R14A) for typical input control wiring for overhead cranes. Transfer switch wiring is not required unless there is a need for pendant operation. The switch can normally be wired without removing it from the receiver cabinet. Any unused switch poles can be used for isolating additional functions.

	WARNING
	Before starting this installation, ensure that the crane power is disconnected and that all applicable safety precautions are followed.

Use the following steps to install the wiring to the receiver board and/or control transfer switch:

1. Disconnect the 'hot' input wire X1 from the pendant and connect it to the (X1) terminal 11 of connector TB1 on the receiver board (A).
2. If you also need 21R14A receiver installation pendant control, connect a wire from the top right lug on the RADIO/PENDANT transfer switch to the X1 input for the pendant (B).
3. Install a wire (16 gauge) from the 'X2' terminal 12 (X2) of connector TB1 to the 'neutral' wire from the Crane Control Power source (C).
4. Install a wire (16 gauge) from the 'MLC' terminal 1 (MLC) of connector TB1 to the main line contactor. This wire will provide a continuous voltage to the ML Coil when the radio is on (D).

Review the steps above to ensure the accuracy of the wiring before applying power to the installation.
Perform 21R14A Installation Testing.

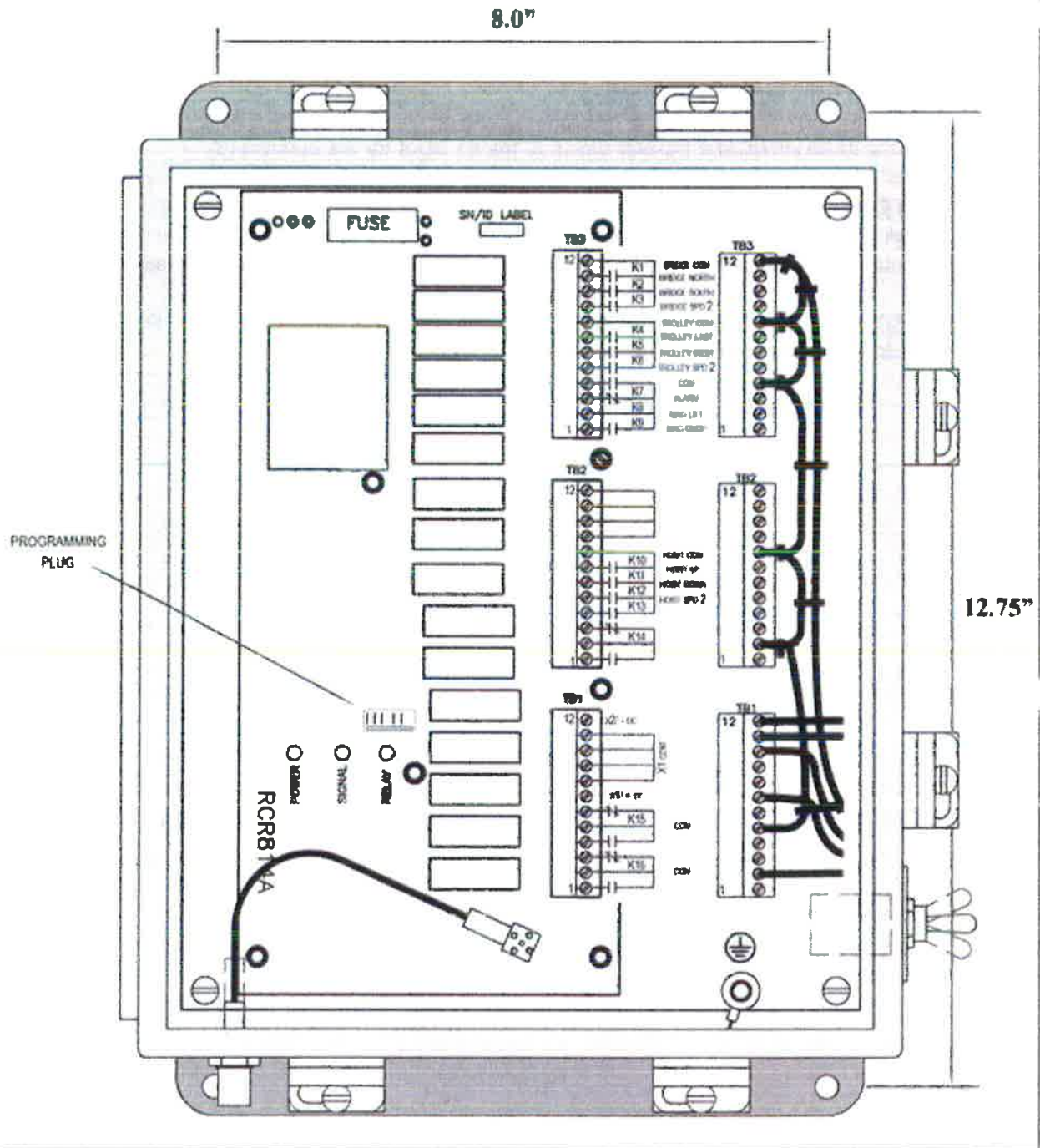

Figure 6: 21R14A Receiver

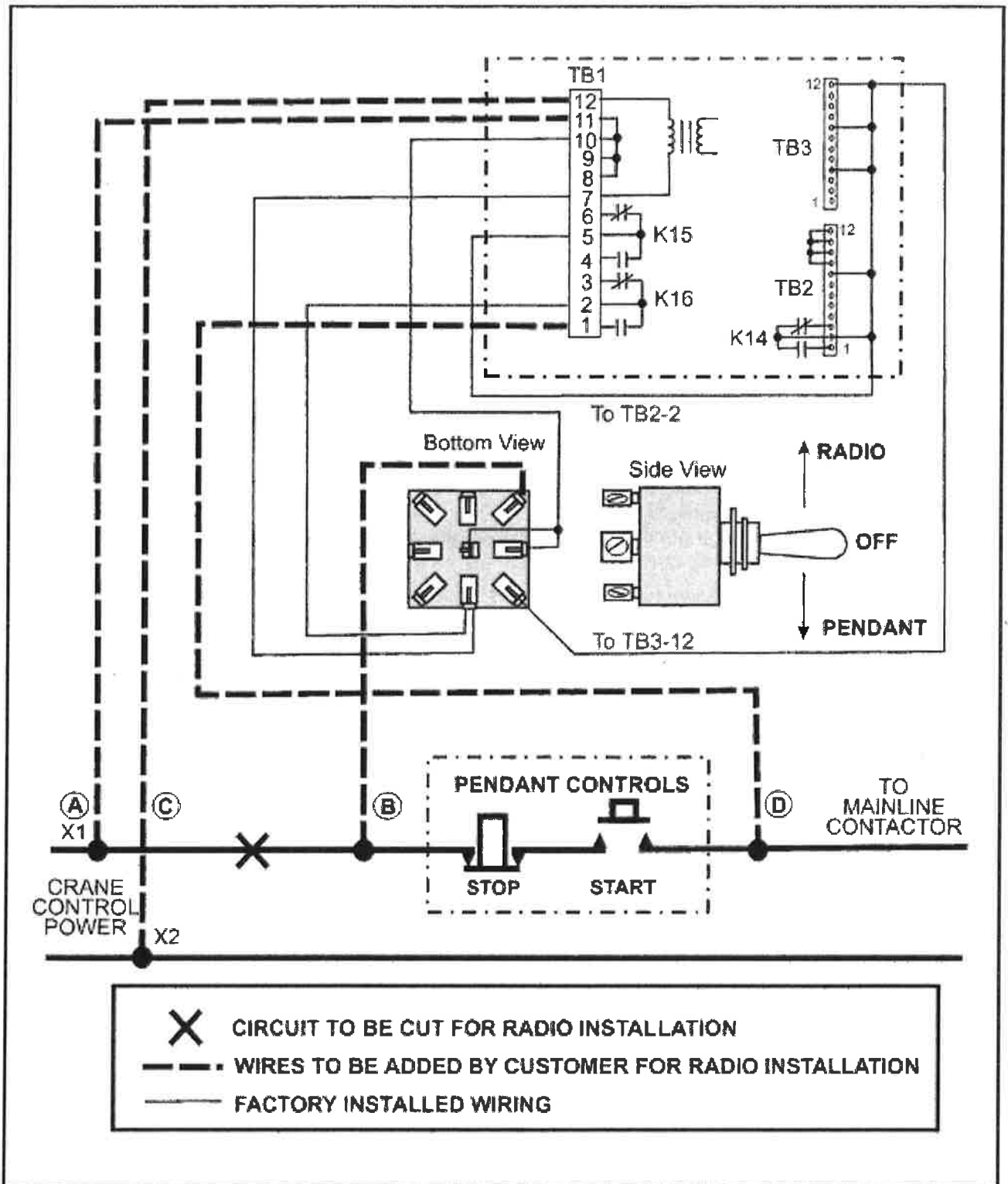

Figure 7: Typical 21R14A Power/Control Wiring

6.5 Installation Procedure -21R22

Refer to Figure 8 and Figure 9.

6.5.1 Power/Control Wiring

The transfer switch is wired so that the crane's Main Line Contactor (MLC) is controlled by the radio MLC and OPR relays when it is in the radio position and by the pendant controls when the switch is in the pendant position. Refer to Figure 9 for typical input control wiring for 21R22 receivers.

Transfer switch wiring is not required unless pendant operation is needed. The switch can normally be wired without removing it from the receiver cabinet. Any unused switch poles can be used for additional isolation.

	WARNING
	Before starting this installation, ensure that the crane power has been disconnected and that all applicable safety precautions are followed.

Use the following steps to install the wiring to the receiver board and/or control transfer switch.

1. Disconnect the 'hot' input wire X1 from the pendant and connect it to terminal 9 of connector TB4 on the receiver board (A).
2. If pendant control of the 21R22 receiver installation is also desired, connect a wire from terminal 7 of connector TB4 on the receiver board to the X1 input for the pendant (B).
3. Install a wire (16 gauge) from terminal 1 (X2) of connector TB4 to the 'neutral' wire from the Crane Control Power source (C).
4. Install a wire (16 gauge) from terminal 4 (MLC) of connector TB4 to the main line contactor. This wire will provide a continuous voltage to the ML Coil when the radio is on (D).

Review the steps above to ensure the accuracy of the wiring before applying power to the installation. Go to 21R14A Installation Testing and perform installation testing.

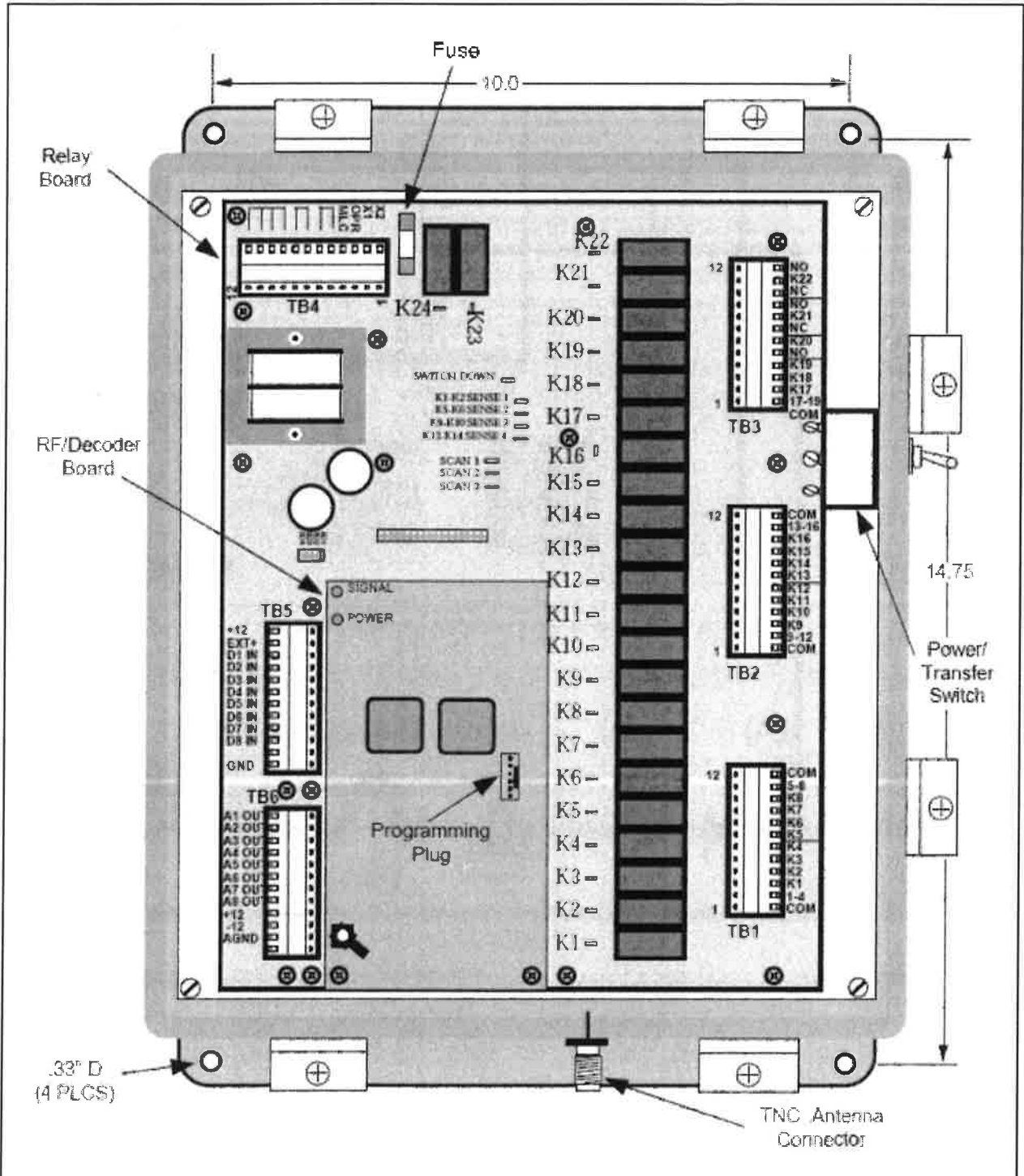

Figure 8: 21R22 Receiver

Note: For R30 and R52 configurations, you must connect a Relay Expansion Board to the proper control voltage.

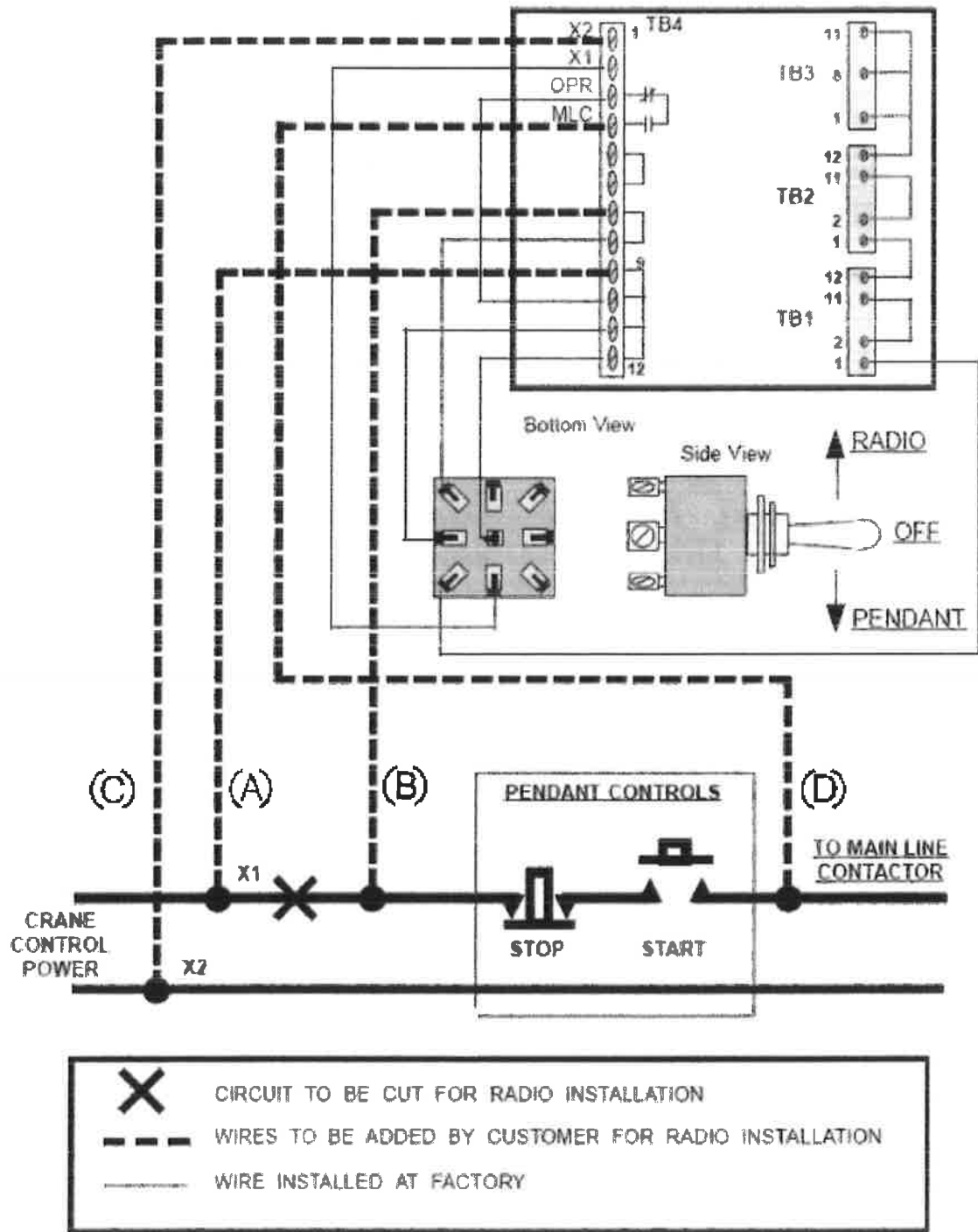

Figure 9: Typical Z1R22 Power/Control Wiring

6.5.2 21R14A Installation Testing

Before putting the system into service, perform the following testing procedure:

1. Apply power to the receiver.
2. Verify that the POWER LED turns ON. Refer to Figure 6.
3. Turn the transmitter to 'ON'.
4. Verify that the K16 and Output LED turn ON; while the alarm is on, verify the Signal LED flashes.
5. Verify that voltage is present at the receiver normally open on output for the MLC.
6. Verify that no voltage is present at any of the relay output terminals that are used for your application.
7. If voltage is present at any output terminal that is used, recheck the system wiring.

6.5.3 21R22 Installation Testing

Before putting the system into service, perform the following testing procedure:

1. Apply power to the receiver.
2. Verify that the POWER LED and the K23 (MLC) LED both turn ON. Refer to Figure 10.
3. Turn on the transmitter.
4. Verify that the K23 LED turns OFF.
5. Verify that the K24 (OPR) LED turns ON and the SIGNAL LED FLASHES. Refer to Figure 11.

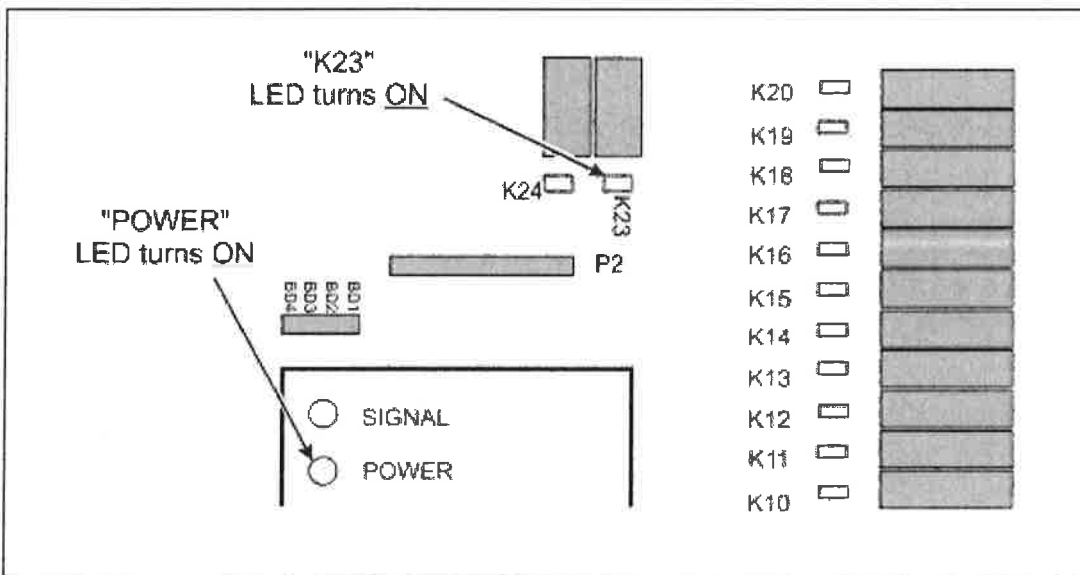

Figure 10: 21R22 Status LED Indicators - Receiver ON (Transmitter OFF)

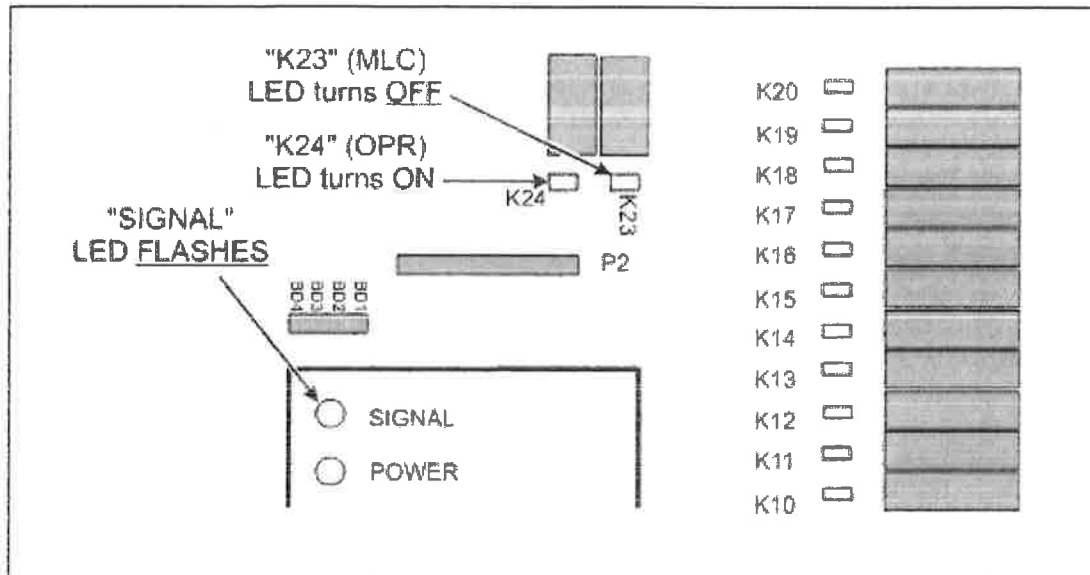

Figure 11: 21R22 Status LED Indicators - Transmitter ON

6. Verify that voltage is present between the receiver output to the Main Line Contactor (M L C) terminal 4 of TB4.
7. Verify that no voltage is present between any of the relay output terminals that are used for your application.
8. If voltage is present at any output terminal that is used, recheck the system wiring

6.6 Installation Procedure – SAFE-T-RANGE (21R22CR)

Laird's 'Safe-T-Range™' is the latest advancement in wireless crane controls. 'Safe-T-Range™' keeps the operator within a pre-determined distance from the crane, thus increasing safety in the workplace. Using an advanced panel antenna design along with programmable logic, a 'Safe-T-Range™'-equipped receiver draws an electronic boundary around the crane and operator. The system then safely stops and inhibits selected functions when the operator steps outside the boundary. This is done without shutting down the main contactor line.

6.6.1 21R22CR Power/Control Wiring

Perform the procedure for installing the [21R22 Power/Control Wiring](#).

6.6.2 21R22CR Antenna Installation

The 21R22CR Receiver must be set up correctly using a special antenna and circuitry for the controlled range function to operate properly. Use the following procedure as a supplement to the 21R22 Installation Procedure.

The antenna for the 21R22CR has a specially shaped pattern that provides a sharp drop-off in signal strength when the operator moves away from the antenna. The antenna has a shaped beam much like a broad flood lamp, as shown in the following illustration.

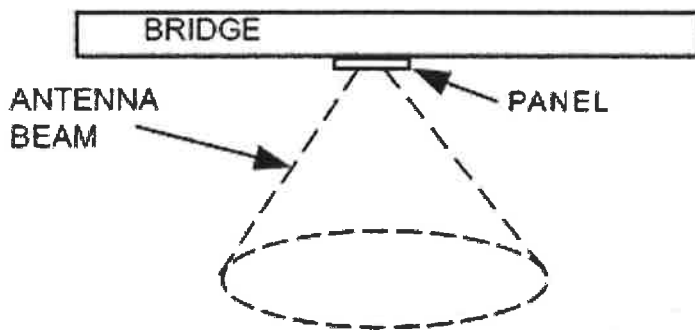

Figure 12: 21R22CR Antenna Pattern

For normal operation, place the antenna as close to the center of the bridge as practical so that the radio control operation is symmetrical about the crane. Mount the antenna underneath the crane with a clear line of sight to the area the crane operator uses. Position the antenna parallel to the ground and have the arrow on its back side pointing toward either end of the bridge.

Use low loss cables to connect the antenna to the receiver if the cable run is in excess of 18 feet. Use Laird P/N 600038-01 (9 ft), 600038-02 (18 ft), or 600048- (length in 25 ft. increments) for up to 100 feet of antenna extension cable.

6.6.3 21R22CR Installation Testing

Perform the tests described in 21R22 Installation Testing on page 23. When these tests have been successfully performed, proceed with the Control Range Alignment and Test.

6.6.4 21R22CR Control Range Alignment and Test

The Control Range circuit has two adjustments. The Range adjustment determines the maximum operating distance from the receiving antenna at which the operator can control critical crane functions (refer to the Control Range circuit board in Figure 13).

The Time Delay adjustment determines the length of time the signal must be below threshold before the Control Range circuit activates. The time delay prevents the Control Range from causing motion jerkiness as the signal varies due to normal operator load movement.

For ease of alignment, adjust the time delay to the minimum (CCW position) while adjusting the range.

Position the operator with an operating transmitter at the desired range limit.

Turn the Range adjustment until the Range indicator LED illuminates. Slowly rotate the Range adjustment clockwise until the Range indicator extinguishes. Note that a voltmeter may be connected to the test points to monitor the voltage for the set point.

Test the operation of the Control Range by having the operator with the transmitter move in and out of range in all directions and readjust the Range adjustment as needed to achieve the desired range limit. Note that the time delay holds the Range LED off for about 1.5 seconds after the operator goes out of range.

When the range is properly adjusted, increase the time delay to the desired value. The adjustment may be set from 1.5 to 10 seconds. Laird recommends a longer time delay to prevent the system from falsely activating due to the normal dynamics of the operator running the crane.

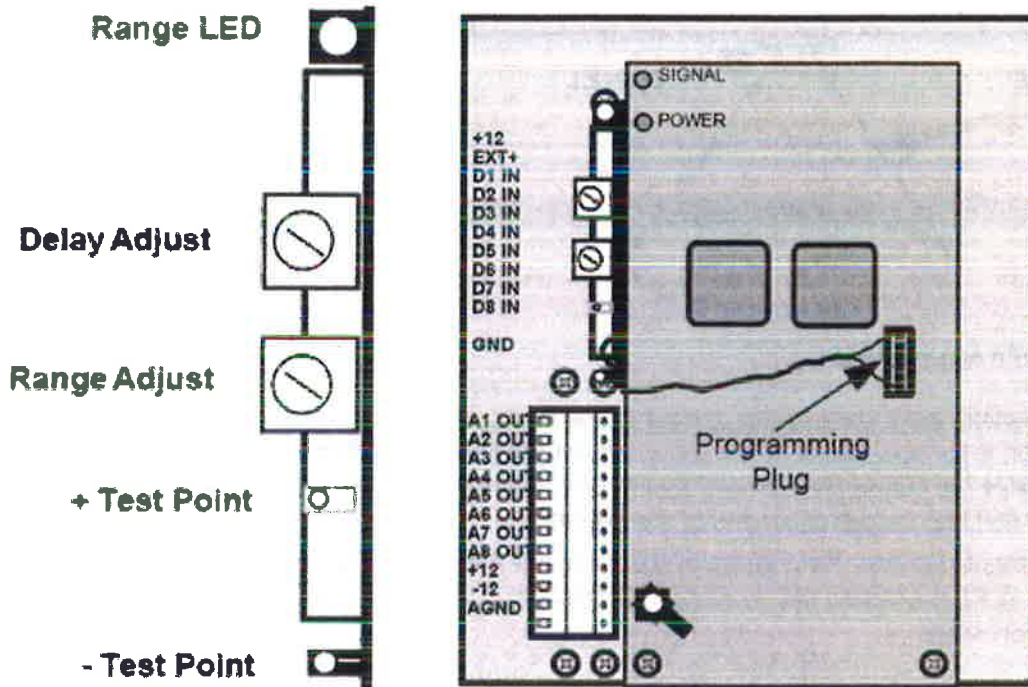

Figure 13: Control Range Circuit Board on 21R22CR Receiver

6.7 Installation Procedure – 22R08A

Refer to Figure 14.

6.7.1 22R08A Power/Control Wiring

The following chart provides instructions for making power connections, depending on the system.

System	Power Connections
120/240/24 VAC	The power connections for Models 22R08A-01(120VAC), 03(240VAC), and 05(24VAC) are made by placing X2 on pin 11 of TB2, and X1 on pin 12 of TB2.
12-24 VDC	The power connections for Model 22R08A-02(12-24DC) is made by placing the – or DC return to pin 11 or TB2 and the +VDC to pin 12 of TB2.

6.7.2 22R08A Output Relay Connections

	WARNING
	Verify that the main input power is OFF before attempting to make connections.

All relay outputs are capable of operating up to 8 Amp, 240 VAC, or 12 VDC circuits. Connecting to equipment or contactors with higher voltage or current ratings requires an intermediate relay.

Total sustained current must not exceed 10 Amps for relays K5 through K8.

Note: When connecting to inductive loads such as relay coils and motors, Laird recommends that snubbers be placed across the load in order to ensure reliability and long life of the output relay contacts.

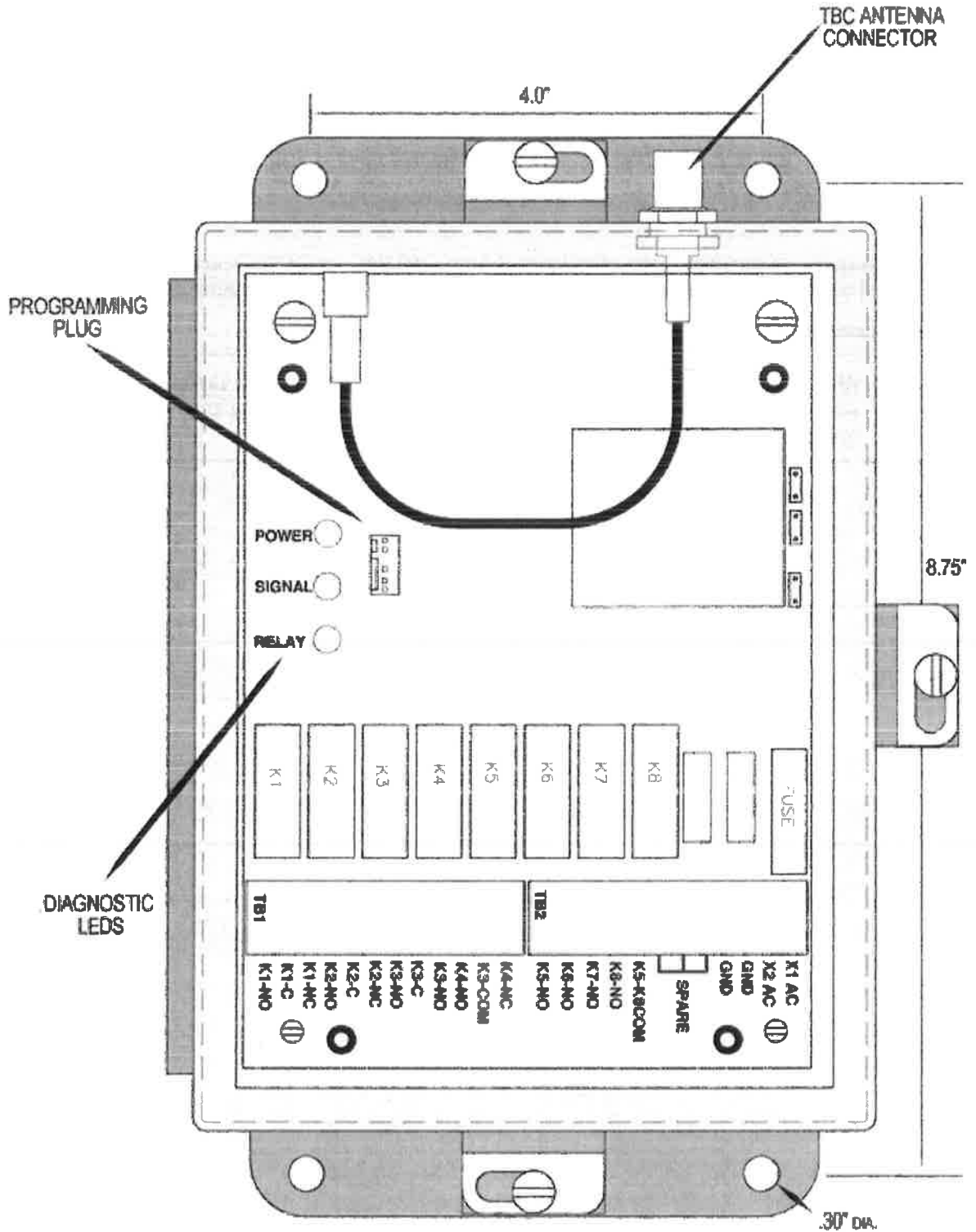

Figure 14: 22R08A Receiver

Figure 16 shows the relay output connections for the 22R08A Receivers. Note that Relays K1 through K4 provide form C (SPDT) outputs. Relays K5 through K8 provide form A (SPST) outputs and share a common bus.

COM refers to the input voltage placed across all relays.

6.7.3 22R08A Installation Testing

Before putting the system into service, perform the following testing procedure:

1. Apply the appropriate power to the receiver (12-24 VDC or 120 VAC).
2. Verify that the POWER (DS3) LED turns 'ON'. Refer to Figure 15.
3. Turn on the transmitter.
4. Verify that the Signal (DS1) LED flashes.
5. Verify that pressing any function switch on the transmitter lights the corresponding relay on the receiver and the Relay (DS2) LED.

Review all of the steps above to ensure the accuracy of the wiring.

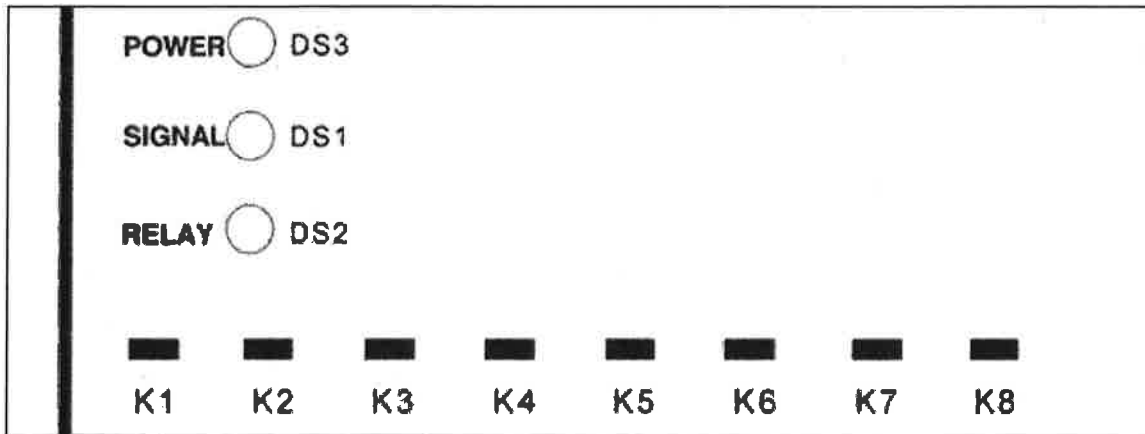

Figure 15: 22R08A LED Status Indicators

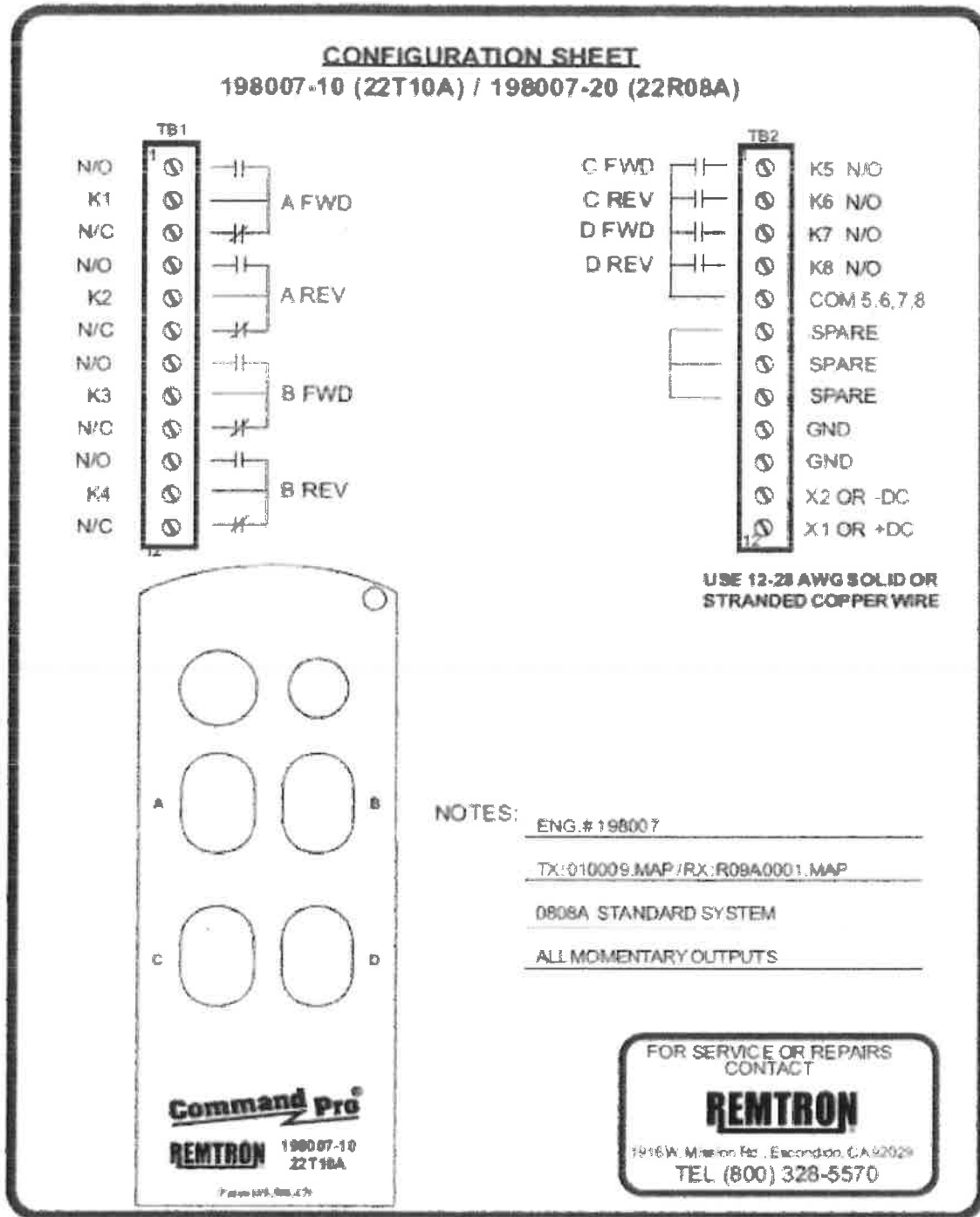

Figure 16: 22R08A Series Receiver Relay Output Connections

7 MAINTENANCE & TROUBLESHOOTING

7.1 Monthly Inspection

Laird recommends performing the following tasks once a month:

- Inspect the transmitter for damage to the keypad and case.
- Inspect all electrical and antenna connections to ensure they are clean and tight.
- Ensure all terminal strips are firmly in place.

7.2 Installation Troubleshooting

If the system fails to operate at the time of installation, or after a system component is repaired, try to remedy the problem by using the following troubleshooting chart. If this does not solve the problem, proceed to the transmitter and receiver troubleshooting charts or call Laird Service.

Table 2: Installation Troubleshooting Chart

Problem	Possible Cause	Remedy
Receiver will not respond to the transmitter.	Wrong transmitter code.	Make sure transmitter is the correct one for the receiver. Re-program the transmitter.
	Transmitter problem.	See the Transmitter Troubleshooting .
	Receiver problem.	See Receiver Troubleshooting .
System has short range.	Antenna placement.	Move the antenna. See Antenna Location .
	Antenna cable shorted or open.	Check cable and connections to the antenna.
Some functions are incorrect.	Programming error.	Check the configuration sheet against system requirements. Call Laird Service.

7.3 Transmitter Troubleshooting

	WARNING
	When testing the transmitter, the receiver can become active and cause system operation. Always assume the system is working and will respond when testing a transmitter.

7.3.1 Normal Operation

When the transmitter is operating normally, the LED indicator emits short flashes at a low rate when no commands are activated, and at a higher rate when a command is activated.

Some transmitters use a red LED only. Others use a multicolored LED that flashes green when no problems are present and turns red when other problems are encountered. The LED also turns AMBER to indicate a hard-wired pendant cable connection on those transmitters equipped with it.

Problem	Possible Cause	Remedy
LED is off.	Transmitter is off.	Press ON/ALARM button.
	Batteries are dead.	Replace batteries.
	Transmitter failure.	Call for service.
LED cycles on-off. (½ sec. on and ½ sec. off)	Batteries getting low.	Change batteries at the next convenient opportunity.
LED flashes Red/Green ('A' series only)	Batteries getting low.	Change batteries at the next convenient opportunity.
LED is on continuously. (LED might flicker slightly)	Switch activated at start.	Restart transmitter with no other switches pressed.
	Transmitter failure.	Call for service.

7.3.2 Transmitter Repair

The transmitter is not considered a field-repairable item and must be returned to the factory for repair. Changing transmitter batteries and ID codes are not considered repairs.

7.3.3 Replacing the Transmitter Batteries

	WARNING
	The transmitter's electronic components are exposed when the back of the case is removed. Take care to prevent dirt or other contaminants from entering the case. Do not allow the circuit to be scraped or damaged in any way.

Handheld Transmitters

Refer to Figure 17 for your particular transmitter.

1. For Standard transmitters, remove the screws on the back of the transmitter and remove the back panel from the case. For 'A' Series IP67 rated transmitters, fully release the two captive screws and remove the battery door.
2. Remove and replace the AA Alkaline batteries. Be sure to observe the correct polarity.
3. For Standard transmitters, reassemble the transmitter in reverse order, making sure the battery wires do not get pinched between the back panel and the case. Tighten the screws snugly. For 'A' Series IP67 rated transmitters, fully replace the battery door and secure using the two captive screws. 'A' Series Battery door screws should be tightened until snug, plus half a turn.

Belly Box Transmitters

1. Open the battery compartment door on the transmitter.
2. Remove and replace the AA Alkaline batteries. **Be sure to observe the correct polarity.**
3. Close the door and tighten the thumb screw.

7.3.4 Changing the Transmitter ID Code

Changing the ID Code requires use of a Laird RAC16 Series programmer. Refer to Figure 17 for the handheld transmitters.

1. Confirm that the batteries are in good condition (refer to [Transmitter Troubleshooting](#)).
2. Remove the screws on the back of the transmitter and remove the back panel from the case. On 'A' Series IP67 rated transmitters, remove the battery door and batteries before removing the back of the transmitter. On the belly box transmitters, open the battery compartment door.
3. Attach the programming plug to the 4-pin connector on the circuit board, or using the belly box adapter, to the mini-DIN connector. Verify that the ID Code is displayed.
4. Enter the new ID Code and press the PRG key. The RAC16 display reads 'SUCCESS'. Verify new ID Code by pressing BKSP and ESC keys.
5. Reassemble the transmitter in reverse order, making sure that the battery wires do not get pinched between the back panel and the case. Tighten the screws snugly. On 'A' Series IP67 rated transmitters, replace the battery door and batteries after replacing the back panel. 'A' Series captive screws should be tightened until snug, plus half a turn.

Refer to the RAC16 Series User Manual for more detailed instructions.

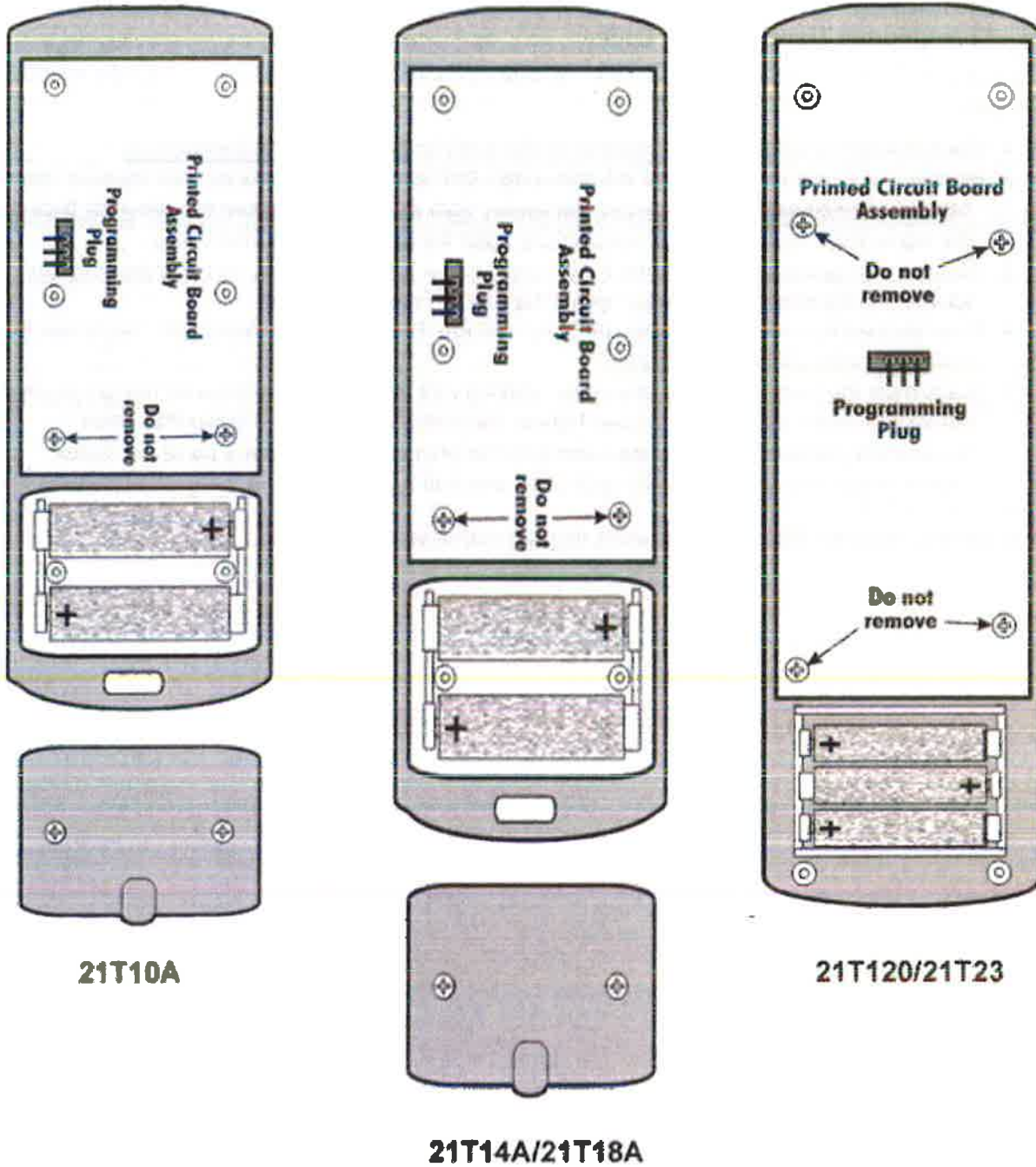

'A' Series IP66/67 transmitter with separate battery door & back panel removed.

Figure 17: Handheld Transmitters - Access to Batteries and Programming Plug

7.4 Transmitter Spare Parts List

7.4.1 Handheld Transmitters

When requesting spare parts, please contact Laird and provide your transmitter model and serial number in the first instance.

Item	Part #
Spare Transmitter (complete)	Use Model No./Serial No.
Shoulder Strap	600057
Case screws, 6-32 5/8 Phillips, stainless steel	500047
Case and battery door screws, captive, 'A' series transmitters	500132
Replacement Transmitter Label	Use Model No./Serial No.

Model	Leather Holster	Clear Protective Pouch
21T10A	620022	620024
21T14A	620023	620025
21T18A	620023	620025
21T20	620009	620012
21T23	620009	620012

7.4.2 Belly Box Transmitters

Item	Part #
Spare Transmitter (complete)	Use Model No./serial No.
Shoulder Carrying Strap	600057
Case retaining screws, T34A/36A	500012
Case retaining screws, T44A/46A	500081

7.5 Receiver Troubleshooting

7.5.1 General

Refer to Figure 6, Figure 8, and Figure 14 for the receiver layouts.

The 21R14A, 21R22, and the 22R08A have diagnostic LEDs plus a LED for each output relay to aid in isolating a problem if one occurs. The 22R08A and 21R14A receivers have 'OUTPUT', 'SIGNAL' and 'POWER' diagnostic LEDs on the front of the receiver case. The 21R14A and 22R08A series use a single circuit board for the receiver and decoder. The 21R22 receiver has 'SIGNAL' and 'POWER' diagnostic LEDs on the front of the receiver case and it uses a RF/Decoder board and a Relay board.

The following table describes the diagnostic LEDs.

LED	Indication
POWER	Receiver operating voltage is present.
Signal Output	A signal is being received that matches the decoder's address.
SIGNAL OUTPUT	Also may indicate scanning mode in receivers with scanning function (except 21R22).
SCAN 1 through SCAN 3 (21R22 only)	These LEDs cycle while receiver is scanning. When on steady, indicates which frequency receiver is locked onto.
K1 through Kxx	Corresponding relays are energized.

When the 21R22 is not receiving a valid signal, an OFF relay pulls in, which ensures that power is removed from the mainline contactor on the crane.

When the receiver is receiving a signal in normal operating mode, the OPR relay drops out and the MLC relay pulls in, allowing the main contactor on the crane to energize.

Note the 21R14A uses one MLC relay.

7.6 Receiver Testing

Note: Before testing, we recommend isolating power to the crane and that all tag/lockout procedures applicable to your facility are applied.

Follow these steps when troubleshooting the Command Pro receivers.

1. Check the POWER indicator. If POWER is not illuminated:
 - a. Make sure the power switch on the right side of the receiver cabinet is in the ON position.
 - b. Check for AC input power between terminals X1 (X1/+DC-SW for R14A) and X2 of the terminal strip. If AC power is present and the POWER on LED is not on, the problem may be in the Relay board.
2. Ensure the transmitter is OFF.
 - a. Switch the receiver power switch off and then on. If no indicators come on after 1 second, the microprocessor circuits are possibly defective. The RF/Decoder board may also be defective.

3. Turn the transmitter ON. The SIGNAL LED should start to flash. If it does not:
 - a. Test the transmitter.
 - b. Verify that the ID Code is the same for the transmitter and receiver.
4. Turn the transmitter ON
 - a. Change the ID Code on the transmitter or receiver so that they are the same. Refer to [Changing the Transmitter ID Code](#) for instructions on setting the ID Code.
5. If only some functions are operating:
 - a. Check to see if the relay LEDs illuminate for inoperative functions.
 - b. Check the output voltage of the respective relays and the electrical circuits.
 - c. Check the condition of the transmitter switches.
 - d. Check the configuration sheet to verify that the problem function has been programmed to the needs of the equipment.
6. If you are experiencing intermittent operation:
 - a. Check all connections; make sure that terminal strips are firmly snapped in place and that the RF/Decoder board is firmly attached to the back of the Relay board.
 - b. Check the antenna connections.
 - c. On AC systems, ensure that noise suppression devices have been placed across the coils of all contactors.
7. If the operating range is short:
 - a. Check all antenna connections and transmitter operation.
 - b. On new installations, verify that the receiver antenna is placed properly.
 - c. If necessary, use an antenna mounting kit to relocate the antenna to a more favorable location.
8. If a new board (21R22 only) does not work:
 - a. Check that the jumper for BD1, BD2, etc. is in the proper place.

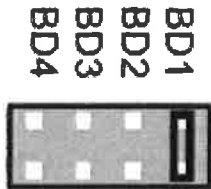

7.6.1 Receiver Repairs

Note: Before repairs are carried out, we recommend that power to the crane is isolated and that all tag/lockout procedures applicable to your facility are applied.

	WARNING
	Throughout the troubleshooting procedure, work is performed within the receiver cabinet while the system is powered. Certain points in the cabinet contain dangerous voltages. Use extreme caution when working inside the cabinet with power on.

7.6.2 Replacing the Circuit Boards

Refer to Figure 6, Figure 8, and Figure 14.

1. Switch the power off to the receiver and open the cabinet door.
2. Unplug the RF coax connector by pulling straight up and gently twisting it back and forth. Unplug all of the electrical connectors.
3. Remove the nut from the ground strap on the mounting plate
4. Remove the four screws from the corners of the receiver assembly mounting plate and remove the assembly from the cabinet.
5. Reassemble in reverse order.

7.6.3 Changing the Receiver ID Code

Changing the ID Code requires use of a Laird RAC16 series programmer.

1. Attach the programming plug to the 6-pin connector on the receiver circuit board. Verify the ID Code is displayed.
2. Enter the new ID Code and press the PRG button. The RAC16 display should read 'SUCCESS'.
3. Remove the programming plug.

Refer to the RAC16 series User Manual for more detailed instructions.

7.7 Receiver Spare Parts List

Item	Part #
Receiver assembly (complete)	Use Model No./serial No.
Receiver Antenna	485026
Snubbers	
230 AC	600049
115 AC	600052
480 AC	600050
250 DC	600051
Antenna cable Assembly w/SMB and panel mount TNC connectors	
22R08A	920040-01
21R14A	920040-04
21R22	920040-05
Panel Antenna 21R22CR "Safe-T-Range"	485034
Antenna Mounting Kit w/angle bracket, 9' & 18' coax cable and connectors	600038 & 600038-02
Antenna Extension Cable, LMR400 with lengths of 25, 50, 75, and 100 feet	600048-01, -02, -03, -04
Fuse - GMC ¼ Amp 250V	458028
Fuse - GMC ¾ Amp 250V	458029

For all other Receiver Spare Part Numbers, please contact Laird and reference the unit Model and Serial Number.

8 WARRANTY STATEMENT FOR COMMAND PRO 21 AND 22 SERIES

8.1 Transmitters

Transmitters are unconditionally warranted against malfunction or breakage for a period of two years and thirty days from the date of the original invoice except in the event of total destruction of the internal circuit board(s), immersion in water or fluid, or destruction by fire. Handheld transmitters used in corrosive environments must be protected by use of the Laird clear, plastic, sealed pouch. The 21T54A is the only transmitter warranted for corrosive environments.

8.2 Receivers and Accessories

Receivers and accessories, in normal and customary use, are conditionally warranted against malfunction or breakage for a period of two years and thirty days from the date of the original invoice. The warranty does not cover: (a) defects or damage resulting from use of the product in other than its normal and customary manner; (b) defects or damage from misuse, accident or neglect; (c) defects from improper testing, operation, maintenance, installation, alteration, modification, or adjustment; (d) damage from unauthorized repair or alterations; (e) damage resulting from over or under voltage or due to lightning strikes; and (f) damage from water or corrosive materials beyond the specification of the case or enclosure.

8.3 General Terms of Warranty

Laird will repair or replace the defective unit, solely at our option in the event of defect or failure to perform as specified, provided the product is returned in accordance with the terms of this warranty. Replacement parts are covered for the balance of the original warranty. All costs of shipping to Laird shall be borne by the purchaser. The warranty covers the cost of return one-way shipping and handling of the product. The return shipment to the customer will be by the same method used for the original shipment of the product.

This warranty does not cover the costs of outside repair service.

This warranty sets forth the full extent of Laird's responsibility regarding the product(s). Repair, replacement, or refund of the purchase price, at Laird's option, are the exclusive remedies. This warranty is given in lieu of all other express warranties. All other warranties, expressed or implied, including without limitation implied warranties of merchantability or fitness for a particular purpose, are specifically excluded.

In no event shall Laird be liable for damages in excess of the purchase price of the product(s), for any loss of use, loss of time, inconvenience, commercial loss, or lost profits or savings or other incidental, special, or consequential damages arising out of the installation, use, or inability to use the product(s), to the full extent that such may be disclaimed by law.

8.4 Service

Products returned for repair (warranty or non-warranty), must be assigned an RA (Return Authorization) number by Laird. To allow us to more effectively address the repair issues, the customer is to provide a detailed description of the specific problem.

Call 800-328-5570 for service or RA assignment. To receive warranty service, deliver or send the product along with the assigned RA number to our factory.

Laird, INC.

1916 W. Mission Rd.

Escondido, CA 92029

APPENDIX I: TRANSMITTER SPECIFICATIONS

Item	Detail
Operating frequency band	902–928 MHz
Channel spacing	300 KHz
Modulation	Digital Frequency Modulation based on Manchester Code. Contains 16-bit address plus 16-bit CRC check.
Power, input	AA cell batteries (Alkaline recommended)
Output power	Meets FCC Part 15 requirements for license-free operation
Antenna	Circuit board, internal or front mounted (belly box)
Indicators	Self-test LED indicator
Ambient Operating Conditions	-20° F to +160° F (-6.6° C to +71° C)

Model	Weight ⁽¹⁾	Dimensions	Commands	Batteries
21T10A	10.9 oz.	2.75" x 7.11" x 1.22"	10	2
21T14A	12.9 oz.	2.75" x 8.48" x 1.22"	14	2
21T18A	12.9 oz.	2.75" x 8.48" x 1.22"	18	2
21T20	1.25 lb.	3.5" x 11.5" x 1.0"	20	3
21T23	1.25 lb.	3.5" x 11.5" x 1.0"	23	3
21T34A	4.5 lbs.	5.0" x 9.0" x 5.5"	⁽²⁾ 24 + 6	3
21T44A	4 lbs.	5.0" x 10.0" x 6.5"	⁽³⁾ 24 + 8	3, 6 or 9
21T54A	4 lbs.	4.5" x 9.5" x 7.5"	⁽³⁾ 24 + 8	3, 6 or 9
21T74A	4.5 lbs.	5.0" x 10.5" x 8.5"	⁽³⁾ 24 + 8	3, 6 or 9

Notes:

⁽¹⁾ Weight includes batteries.

⁽²⁾ 21T34A can transmit 24 discrete plus 6 stepped lever commands.

⁽³⁾ 21T44A, 54A, & 74A can transmit 24 discrete plus 8 analog commands.

Certifications

Model	FCC ID#	Industry Canada Certification #
21T10A	EGT810TX	249 710 2624
21T14A	EGT814TX	249 710 31887
21T18A	EGT818TX	249 710 32099
21T20	EGT820TX	249 710 31891
21T23	EGT823TX	249 710 31892
21T34A	EGT834TX	249 710 31890
21T44A	EGT844TX	249 710 31889
21T54A	EGT854TX	249 710 31893

APPENDIX II: RECEIVER SPECIFICATIONS

Item	Detail
Operating frequency band	902 - 928 MHz
Channel spacing	300 KHz
Modulation	Digital Frequency Modulation based on Manchester Code. Contains 16-bit address plus 16 bit CRC check.
Receiver Type	Dual Conversion FM
Sensitivity	1 μ V usable
IF Bandwidth	180 KHz
Antenna	3" tuned element
Decoder	Microprocessor-controlled
Response Time	60 Milliseconds
Safety Features	Address check ♦ CRC code check ♦ Format test ♦ Signal check ♦ Transmitter status checks ♦ Self-test
Indicators	Full function diagnostics LEDs for easy troubleshooting
Output Contacts	8 Amp @ 230 VAC
Logic Base	Programmable for each application
Power Requirements	115 VAC or 230 VAC, 1 phase, 50 – 60Hz, 24 VAC, 12 VDC, 24 VDC
Maximum Current Drain	0.12 Amp @ 115 VAC
Ambient Operating Temperature	-20° F to +160° F (-6.6° C to +71° C)

Model	Dimensions	Command Functions
21R14A	10.5" x 12.5" x 5.5"	14
21R22	12" x 14" x 6"	22
22R08A	8" x 10" x 4.5"	8

Certifications

Model	FCC ID#	Industry Canada Certification #
21R14A	(1)	249 710 31887
21R22	(1)	249 710 32139A
22R08A	(1)	249 710 32139A

Note: (1) Self Certified for operation under Part 15 of the FCC rules.

SUPPORT

NAME	PHONE	FAX	CONTACT
WACS-Escondido 1916 West Mission Road Escondido, CA 92029	760-737-7800	760-737-7810	cgi.mail@lairdtech.com
WACS-Georgetown 150 Armstrong Ave. Units 5 & 6 Georgetown, Ontario L7G 5G8	905/873 9440	905/873-9449	cgi.mail@lairdtech.com
WACS-Montreal 3850 Griffith Ave. St. Laurent PQ H4T 1A7 Canada	514-908-1659	514-908-1673	cgi.mail@lairdtech.com
WACS-Sharpville 58 West Shenango St. Sharpville, PA 16150	724-962-3571	724-962-4310	cgi.mail@lairdtech.com
WACS – BRAZIL Cattron-Theimeg Americas Ltda. Rua Antonio Rodrigues De Carvalho, 435 13033-610 Campinas – SP- Brazil	55/19/3243-7803	55/19/3243-9258	
WACS – UK Cattron-Theimeg UK Ltd Riverdene Business Park Unit J Molesey Road Hersham Walton-on-Thames Surrey KT12 4RG	44/1/932-247511	44/1/932-220937	
WACS – SOUTH AFRICA Cattron-Theimeg Africa (Pty) Ltd. <i>Mail:</i> P.O Box 15444 Farrarmere, Benoni Gauteng 1518, South Africa <i>Shipping:</i> 24 O’Rielly Merry Road Rynfield, Benoni Gauteng 1518, South Africa	27/11/425-1123	27/11/849-5717	
WACS – CHINA Cattron Group International Asia-Pacific Suite 417 Mingguang Business Building 351 Zhaohua Road, Shanghai 200050 China	86/21/31200188	86/21/60290498	
WACS – GERMANY Cattron-Theimeg Europe GmbH & Co. Krefelder Strasse 423-425 41066 Mönchengladbach Germany	49/2161/6363/0	49/2161/6363/100	