

LTA 2.0 Telescopic Extraction Arm

Safety Depends on You

Lincoln arc welding and cutting equipment is designed and built with safety in mind. However, your overall safety can be increased by proper installation ... and thoughtful operation on your part. **DO NOT INSTALL, OPERATE OR REPAIR THIS EQUIPMENT WITHOUT READING THIS MANUAL AND THE SAFETY PRECAUTIONS CONTAINED THROUGHOUT.** And, most importantly, think before you act and be careful.

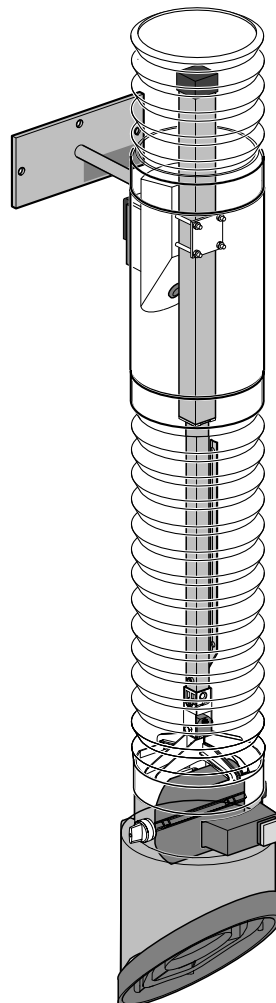

Date of Purchase: _____

Serial Number: _____

Code Number: _____

Model: _____

Where Purchased: _____

OPERATOR'S MANUAL



• World's Leader in Welding and Cutting Products •

• Sales and Service through Subsidiaries and Distributors Worldwide •

Cleveland, Ohio 44117-1199 U.S.A. TEL: 216.481.8100 FAX: 216.486.1751 WEB SITE: www.lincolnelectric.com

⚠ WARNING

⚠ CALIFORNIA PROPOSITION 65 WARNINGS ⚠

Diesel engine exhaust and some of its constituents are known to the State of California to cause cancer, birth defects, and other reproductive harm.

The Above For Diesel Engines

The engine exhaust from this product contains chemicals known to the State of California to cause cancer, birth defects, or other reproductive harm.

The Above For Gasoline Engines

ARC WELDING CAN BE HAZARDOUS. PROTECT YOURSELF AND OTHERS FROM POSSIBLE SERIOUS INJURY OR DEATH. KEEP CHILDREN AWAY. PACEMAKER WEARERS SHOULD CONSULT WITH THEIR DOCTOR BEFORE OPERATING.

Read and understand the following safety highlights. For additional safety information, it is strongly recommended that you purchase a copy of "Safety in Welding & Cutting - ANSI Standard Z49.1" from the American Welding Society, P.O. Box 351040, Miami, Florida 33135 or CSA Standard W117.2-1974. A Free copy of "Arc Welding Safety" booklet E205 is available from the Lincoln Electric Company, 22801 St. Clair Avenue, Cleveland, Ohio 44117-1199.

BE SURE THAT ALL INSTALLATION, OPERATION, MAINTENANCE AND REPAIR PROCEDURES ARE PERFORMED ONLY BY QUALIFIED INDIVIDUALS.



FOR ENGINE powered equipment.

1.a. Turn the engine off before troubleshooting and maintenance work unless the maintenance work requires it to be running.



1.b. Operate engines in open, well-ventilated areas or vent the engine exhaust fumes outdoors.



1.c. Do not add the fuel near an open flame welding arc or when the engine is running. Stop the engine and allow it to cool before refueling to prevent spilled fuel from vaporizing on contact with hot engine parts and igniting. Do not spill fuel when filling tank. If fuel is spilled, wipe it up and do not start engine until fumes have been eliminated.



1.d. Keep all equipment safety guards, covers and devices in position and in good repair. Keep hands, hair, clothing and tools away from V-belts, gears, fans and all other moving parts when starting, operating or repairing equipment.

1.e. In some cases it may be necessary to remove safety guards to perform required maintenance. Remove guards only when necessary and replace them when the maintenance requiring their removal is complete. Always use the greatest care when working near moving parts.

1.f. Do not put your hands near the engine fan. Do not attempt to override the governor or idler by pushing on the throttle control rods while the engine is running.

1.g. To prevent accidentally starting gasoline engines while turning the engine or welding generator during maintenance work, disconnect the spark plug wires, distributor cap or magneto wire as appropriate.

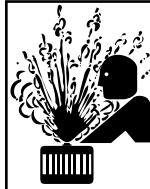

1.h. To avoid scalding, do not remove the radiator pressure cap when the engine is hot.



ELECTRIC AND MAGNETIC FIELDS may be dangerous

2.a. Electric current flowing through any conductor causes localized Electric and Magnetic Fields (EMF). Welding current creates EMF fields around welding cables and welding machines

2.b. EMF fields may interfere with some pacemakers, and welders having a pacemaker should consult their physician before welding.

2.c. Exposure to EMF fields in welding may have other health effects which are now not known.

2.d. All welders should use the following procedures in order to minimize exposure to EMF fields from the welding circuit:

2.d.1. Route the electrode and work cables together - Secure them with tape when possible.

2.d.2. Never coil the electrode lead around your body.

2.d.3. Do not place your body between the electrode and work cables. If the electrode cable is on your right side, the work cable should also be on your right side.

2.d.4. Connect the work cable to the workpiece as close as possible to the area being welded.

2.d.5. Do not work next to welding power source.

Mar '95



ELECTRIC SHOCK can kill.

- 3.a. The electrode and work (or ground) circuits are electrically "hot" when the welder is on. Do not touch these "hot" parts with your bare skin or wet clothing. Wear dry, hole-free gloves to insulate hands.
- 3.b. Insulate yourself from work and ground using dry insulation. Make certain the insulation is large enough to cover your full area of physical contact with work and ground.
- In addition to the normal safety precautions, if welding must be performed under electrically hazardous conditions (in damp locations or while wearing wet clothing; on metal structures such as floors, gratings or scaffolds; when in cramped positions such as sitting, kneeling or lying, if there is a high risk of unavoidable or accidental contact with the workpiece or ground) use the following equipment:**
- Semiautomatic DC Constant Voltage (Wire) Welder.
 - DC Manual (Stick) Welder.
 - AC Welder with Reduced Voltage Control.
- 3.c. In semiautomatic or automatic wire welding, the electrode, electrode reel, welding head, nozzle or semiautomatic welding gun are also electrically "hot".
- 3.d. Always be sure the work cable makes a good electrical connection with the metal being welded. The connection should be as close as possible to the area being welded.
- 3.e. Ground the work or metal to be welded to a good electrical (earth) ground.
- 3.f. Maintain the electrode holder, work clamp, welding cable and welding machine in good, safe operating condition. Replace damaged insulation.
- 3.g. Never dip the electrode in water for cooling.
- 3.h. Never simultaneously touch electrically "hot" parts of electrode holders connected to two welders because voltage between the two can be the total of the open circuit voltage of both welders.
- 3.i. When working above floor level, use a safety belt to protect yourself from a fall should you get a shock.
- 3.j. Also see Items 6.c. and 8.



ARC RAYS can burn.

- 4.a. Use a shield with the proper filter and cover plates to protect your eyes from sparks and the rays of the arc when welding or observing open arc welding. Headshield and filter lens should conform to ANSI Z87.1 standards.
- 4.b. Use suitable clothing made from durable flame-resistant material to protect your skin and that of your helpers from the arc rays.
- 4.c. Protect other nearby personnel with suitable, non-flammable screening and/or warn them not to watch the arc nor expose themselves to the arc rays or to hot spatter or metal.



FUMES AND GASES can be dangerous.

- 5.a. Welding may produce fumes and gases hazardous to health. Avoid breathing these fumes and gases. When welding, keep your head out of the fume. Use enough ventilation and/or exhaust at the arc to keep fumes and gases away from the breathing zone. **When welding with electrodes which require special ventilation such as stainless or hard facing (see instructions on container or MSDS) or on lead or cadmium plated steel and other metals or coatings which produce highly toxic fumes, keep exposure as low as possible and below Threshold Limit Values (TLV) using local exhaust or mechanical ventilation. In confined spaces or in some circumstances, outdoors, a respirator may be required. Additional precautions are also required when welding on galvanized steel.**
- 5.b. Do not weld in locations near chlorinated hydrocarbon vapors coming from degreasing, cleaning or spraying operations. The heat and rays of the arc can react with solvent vapors to form phosgene, a highly toxic gas, and other irritating products.
- 5.c. Shielding gases used for arc welding can displace air and cause injury or death. Always use enough ventilation, especially in confined areas, to insure breathing air is safe.
- 5.d. Read and understand the manufacturer's instructions for this equipment and the consumables to be used, including the material safety data sheet (MSDS) and follow your employer's safety practices. MSDS forms are available from your welding distributor or from the manufacturer.
- 5.e. Also see item 1.b.

Mar '95

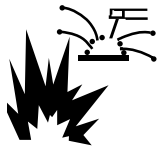

WELDING SPARKS can cause fire or explosion.

6.a. Remove fire hazards from the welding area. If this is not possible, cover them to prevent the welding sparks from starting a fire.

Remember that welding sparks and hot materials from welding can easily go through small cracks and openings to adjacent areas. Avoid welding near hydraulic lines. Have a fire extinguisher readily available.

- 6.b. Where compressed gases are to be used at the job site, special precautions should be used to prevent hazardous situations. Refer to "Safety in Welding and Cutting" (ANSI Standard Z49.1) and the operating information for the equipment being used.
- 6.c. When not welding, make certain no part of the electrode circuit is touching the work or ground. Accidental contact can cause overheating and create a fire hazard.
- 6.d. Do not heat, cut or weld tanks, drums or containers until the proper steps have been taken to insure that such procedures will not cause flammable or toxic vapors from substances inside. They can cause an explosion even though they have been "cleaned". For information, purchase "Recommended Safe Practices for the Preparation for Welding and Cutting of Containers and Piping That Have Held Hazardous Substances", AWS F4.1 from the American Welding Society (see address above).
- 6.e. Vent hollow castings or containers before heating, cutting or welding. They may explode.
- 6.f. Sparks and spatter are thrown from the welding arc. Wear oil free protective garments such as leather gloves, heavy shirt, cuffless trousers, high shoes and a cap over your hair. Wear ear plugs when welding out of position or in confined places. Always wear safety glasses with side shields when in a welding area.
- 6.g. Connect the work cable to the work as close to the welding area as practical. Work cables connected to the building framework or other locations away from the welding area increase the possibility of the welding current passing through lifting chains, crane cables or other alternate circuits. This can create fire hazards or overheat lifting chains or cables until they fail.
- 6.h. Also see item 1.c.

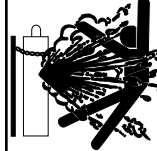

CYLINDER may explode if damaged.

7.a. Use only compressed gas cylinders containing the correct shielding gas for the process used and properly operating regulators designed for the gas and pressure used. All hoses, fittings, etc. should be suitable for the application and maintained in good condition.

- 7.b. Always keep cylinders in an upright position securely chained to an undercarriage or fixed support.
- 7.c. Cylinders should be located:
 - Away from areas where they may be struck or subjected to physical damage.
 - A safe distance from arc welding or cutting operations and any other source of heat, sparks, or flame.
- 7.d. Never allow the electrode, electrode holder or any other electrically "hot" parts to touch a cylinder.
- 7.e. Keep your head and face away from the cylinder valve outlet when opening the cylinder valve.
- 7.f. Valve protection caps should always be in place and hand tight except when the cylinder is in use or connected for use.
- 7.g. Read and follow the instructions on compressed gas cylinders, associated equipment, and CGA publication P-1, "Precautions for Safe Handling of Compressed Gases in Cylinders," available from the Compressed Gas Association 1235 Jefferson Davis Highway, Arlington, VA 22202.



FOR ELECTRICALLY powered equipment.

- 8.a. Turn off input power using the disconnect switch at the fuse box before working on the equipment.
- 8.b. Install equipment in accordance with the U.S. National Electrical Code, all local codes and the manufacturer's recommendations.
- 8.c. Ground the equipment in accordance with the U.S. National Electrical Code and the manufacturer's recommendations.

Mar '95

PRÉCAUTIONS DE SÛRETÉ

Pour votre propre protection lire et observer toutes les instructions et les précautions de sûreté spécifiques qui paraissent dans ce manuel aussi bien que les précautions de sûreté générales suivantes:

Sûreté Pour Soudage A L'Arc

1. Protégez-vous contre la secousse électrique:
 - a. Les circuits à l'électrode et à la pièce sont sous tension quand la machine à souder est en marche. Eviter toujours tout contact entre les parties sous tension et la peau nue ou les vêtements mouillés. Porter des gants secs et sans trous pour isoler les mains.
 - b. Faire très attention de bien s'isoler de la masse quand on soude dans des endroits humides, ou sur un plancher métallique ou des grilles métalliques, principalement dans les positions assis ou couché pour lesquelles une grande partie du corps peut être en contact avec la masse.
 - c. Maintenir le porte-électrode, la pince de masse, le câble de soudage et la machine à souder en bon et sûr état de fonctionnement.
 - d. Ne jamais plonger le porte-électrode dans l'eau pour le refroidir.
 - e. Ne jamais toucher simultanément les parties sous tension des porte-électrodes connectés à deux machines à souder parce que la tension entre les deux pinces peut être le total de la tension à vide des deux machines.
 - f. Si on utilise la machine à souder comme une source de courant pour soudage semi-automatique, ces précautions pour le porte-électrode s'appliquent aussi au pistolet de soudage.
2. Dans le cas de travail au dessus du niveau du sol, se protéger contre les chutes dans le cas où on reçoit un choc. Ne jamais enrouler le câble-électrode autour de n'importe quelle partie du corps.
3. Un coup d'arc peut être plus sévère qu'un coup de soleil, donc:
 - a. Utiliser un bon masque avec un verre filtrant approprié ainsi qu'un verre blanc afin de se protéger les yeux du rayonnement de l'arc et des projections quand on soude ou quand on regarde l'arc.
 - b. Porter des vêtements convenables afin de protéger la peau de soudeur et des aides contre le rayonnement de l'arc.
 - c. Protéger l'autre personnel travaillant à proximité au soudage à l'aide d'écrans appropriés et non-inflammables.
4. Des gouttes de laitier en fusion sont émises de l'arc de soudage. Se protéger avec des vêtements de protection libres de l'huile, tels que les gants en cuir, chemise épaisse, pantalons sans revers, et chaussures montantes.
5. Toujours porter des lunettes de sécurité dans la zone de soudage. Utiliser des lunettes avec écrans latéraux dans les zones où l'on pique le laitier.
6. Eloigner les matériaux inflammables ou les recouvrir afin de prévenir tout risque d'incendie dû aux étincelles.
7. Quand on ne soude pas, poser la pince à un endroit isolé de la masse. Un court-circuit accidentel peut provoquer un échauffement et un risque d'incendie.
8. S'assurer que la masse est connectée le plus près possible de la zone de travail qu'il est pratique de le faire. Si on place la masse sur la charpente de la construction ou d'autres endroits éloignés de la zone de travail, on augmente le risque de voir passer le courant de soudage par les chaînes de levage, câbles de grue, ou autres circuits. Cela peut provoquer des risques d'incendie ou d'échauffement des chaînes et des câbles jusqu'à ce qu'ils se rompent.
9. Assurer une ventilation suffisante dans la zone de soudage. Ceci est particulièrement important pour le soudage de tôles galvanisées plombées, ou cadmiées ou tout autre métal qui produit des fumées toxiques.
10. Ne pas souder en présence de vapeurs de chlore provenant d'opérations de dégraissage, nettoyage ou pistologie. La chaleur ou les rayons de l'arc peuvent réagir avec les vapeurs du solvant pour produire du phosgène (gas fortement toxique) ou autres produits irritants.
11. Pour obtenir de plus amples renseignements sur la sûreté, voir le code "Code for safety in welding and cutting" CSA Standard W 117.2-1974.

PRÉCAUTIONS DE SÛRETÉ POUR LES MACHINES À SOUDER À TRANSFORMATEUR ET À REDRESSEUR

1. Relier à la terre le châssis du poste conformément au code de l'électricité et aux recommandations du fabricant. Le dispositif de montage ou la pièce à souder doit être branché à une bonne mise à la terre.
2. Autant que possible, l'installation et l'entretien du poste seront effectués par un électricien qualifié.
3. Avant de faire des travaux à l'intérieur de poste, la débrancher à l'interrupteur à la boîte de fusibles.
4. Garder tous les couvercles et dispositifs de sûreté à leur place.

Thank You — for selecting a **QUALITY** product by Lincoln Electric. We want you to take pride in operating this Lincoln Electric Company product •• as much pride as we have in bringing this product to you!

Please Examine Carton and Equipment For Damage Immediately

When this equipment is shipped, title passes to the purchaser upon receipt by the carrier. Consequently, Claims for material damaged in shipment must be made by the purchaser against the transportation company at the time the shipment is received.

Please record your equipment identification information below for future reference. This information can be found on your machine nameplate.

Model Name & Number _____

Code & Serial Number _____

Date of Purchase _____

Whenever you request replacement parts for or information on this equipment always supply the information you have recorded above.

Read this Operators Manual completely before attempting to use this equipment. Save this manual and keep it handy for quick reference. Pay particular attention to the safety instructions we have provided for your protection. The level of seriousness to be applied to each is explained below:

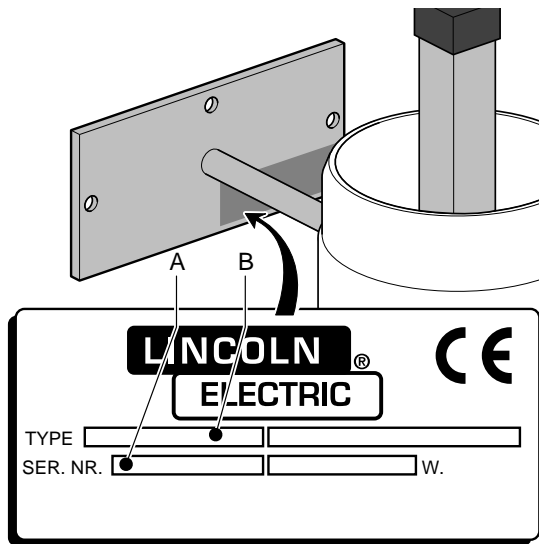

The identification plate specifies:

- A. Serial number
- B. Product name

⚠ WARNING

This statement appears where the information **must** be followed **exactly** to avoid **serious personal injury** or **loss of life**.

⚠ CAUTION

This statement appears where the information **must** be followed to avoid **minor personal injury** or **damage to this equipment**.

TABLE OF CONTENTS

	Page
Safety	i-iv
<hr/>	
Installation	Section A
Technical Specifications.....	A-1
Safety Precautions	A-2
General Description.....	A-2
Mounting the LTA 2.0 Telescopic Arm	A-2
Adjusting the Friction Settings of the Arm	A-3
<hr/>	
Operation	Section B
Safety Instructions	B-1
Operating Instructions	B-1
<hr/>	
Maintenance	Section C
Routine Maintenance	C-1
<hr/>	
Trouble Shooting	Section D
Trouble Shooting Chart	D-1
<hr/>	
Parts Manual	Appendix
Parts Pages	1-4
<hr/>	

Technical Specifications- LTA 2.0 Telescopic Extraction Arm

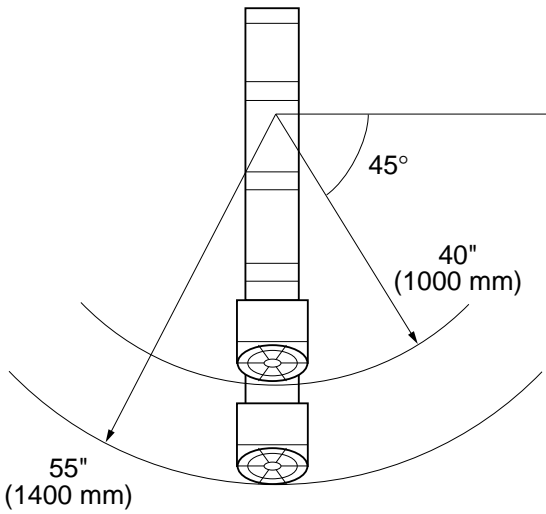

GENERAL	
Sales Specification	K1655-3
Description	LTA 2.0, Telescopic Extraction Arm
Arm Length	39.5 - 55 in. (1000 - 1400 mm)
Nominal Diameter	8 in. (208 mm)
Airflow Capacity	353 - 942 CFM (600 - 1,600 m ³ /h)
Weight	15.4 lbs. (7 kg)

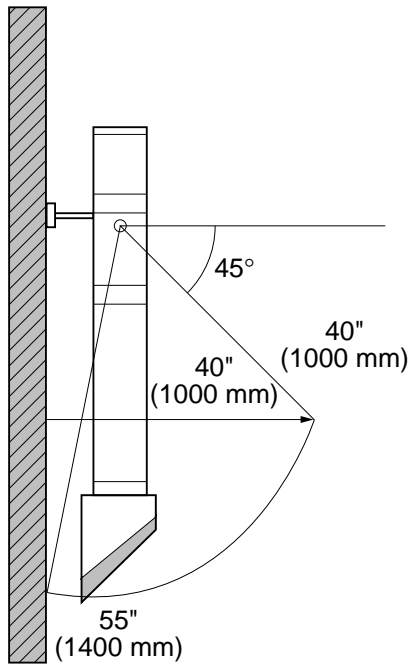

AMBIENT CONDITIONS	
Min. Temperature	41°F (5°C)
Max. Temperature	113°F (45°C)
Max. Rel. Humidity	80%

PRESSURE DROP - SF2400 Fan and LTA 2.0 Arm

Vacuum (inches WG) vs. Air Flow (CFM)

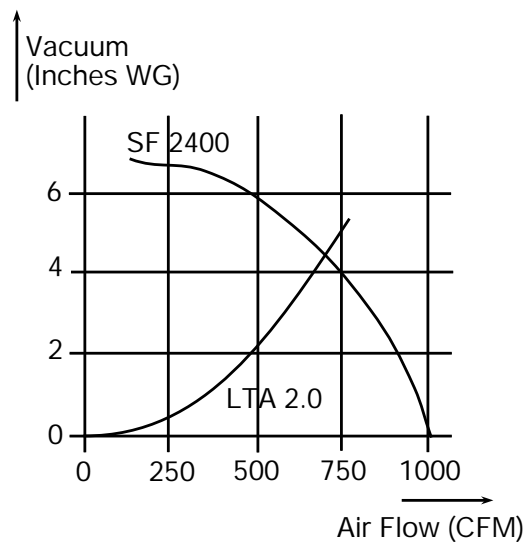

NOTE: Technical Specifications are subject to change without prior notice. Specifications and guarantees are valid only when specified spare parts and filters are used.

LTA 2.0 TELESCOPIC EXTRACTION ARM



Read this entire installation section before you start installation.

SAFETY PRECAUTIONS

Do not attempt to use this equipment until you have thoroughly read all installation, operating and maintenance information supplied with your equipment. They include important safety precautions and detailed operating and maintenance instructions.

WARNING



ELECTRIC SHOCK can kill.

- Do not touch electrically live parts such as internal wiring.
- Turn the input power off at the fuse box before working on this equipment.
- Have a qualified person install and service this equipment.



MOVING PARTS can injure.

- Do not operate with covers open or filter removed.
- Keep away from moving parts.

Only qualified personnel should install, use or service this equipment.

GENERAL DESCRIPTION

Lincoln's K1655-3 LTA 2.0 fume extraction arm telescopes 3-5 ft. long, making it ideal for small workstation or booth applications. It is intended for use with a low-vacuum, high-volume extraction fan.

The telescopic arm is commonly installed with a SF2400 Wall-mounted Fan. Extracted air can be vented outside through the Air Exhaust Silencer, or filtered through a Statiflex 200-M Wall-Mounted Filter Unit. The Starter/Overload Switch for the SF2400 Extraction Fan protects the motor against overcurrent. The optional Lamp Kit for Wall-Mounted Systems provides a work lamp and remote, hood-mounted switches for the lamp and extraction fan, replacing the starter/overload switch. The Automatic Start/Stop Arc Sensor can be installed with the Lamp Kit to turn the extraction fan on and off automatically when it detects a welding arc flash.

Other Available Equipment:

- K1656-1 SF2400 Stationary Fan
(requires K1657-2 Motor Mounting Bracket)
- K1657-2 Motor Mounting Bracket
- K1534-2 Air Exhaust Silencer
- K1654-1 Statiflex 200-M, Wall-mounted Filter Unit
- K1494-2 Starter/Overload Switch
(unnecessary if using a K1669-2 Lamp Kit)
- K1669-2 Lamp Kit for Wall-Mounted Systems
(replaces K1494-2 Starter/OL Switch)
- K1670-1 Automatic Start/Stop Arc Sensor
(requires K1669-2 Lamp Kit)

This manual describes installation of the following equipment:

Mounting the LTA 2.0 Telescopic Arm

- K1655-3 LTA 2.0 Telescopic Extraction Arm

The Motor Mounting Bracket is unnecessary unless an SF2400 Stationary Fan is used. For complete installation instructions for a Telescopic Arm System including SF2400 Fan, Motor Mounting Bracket, and Starter/Overload Switch or Lamp Kit, refer to the SF2400 Stationary Fan manual.

For information on installation of the Statiflex 200-M wall-mounted filter unit, refer to the Statiflex 200-M manual. For information on installation of the Air Exhaust Silencer, refer to the SF2400 Stationary Fan manual.

WARNING

Only qualified personnel should install, use or service this equipment.

MOUNTING THE TELESCOPIC ARM

WARNING

The installer is responsible for following local safety codes and regulations.

Before drilling, verify locations of existing gas, water, or electrical conduits.

The K1655-3 LTA 2.0, Telescopic Arm includes:

- Telescopic Arm, Assembled
- Flexible Hose, (2) 8" Rubber Seals for connection to fan

If installing the Telescopic Arm with an SF2400 Fan, refer to the SF2400 Fan manual for installation instructions.

LTA 2.0 TELESCOPIC EXTRACTION ARM



MOUNTING THE LTA 2.0 TELESCOPIC ARM

(continued)

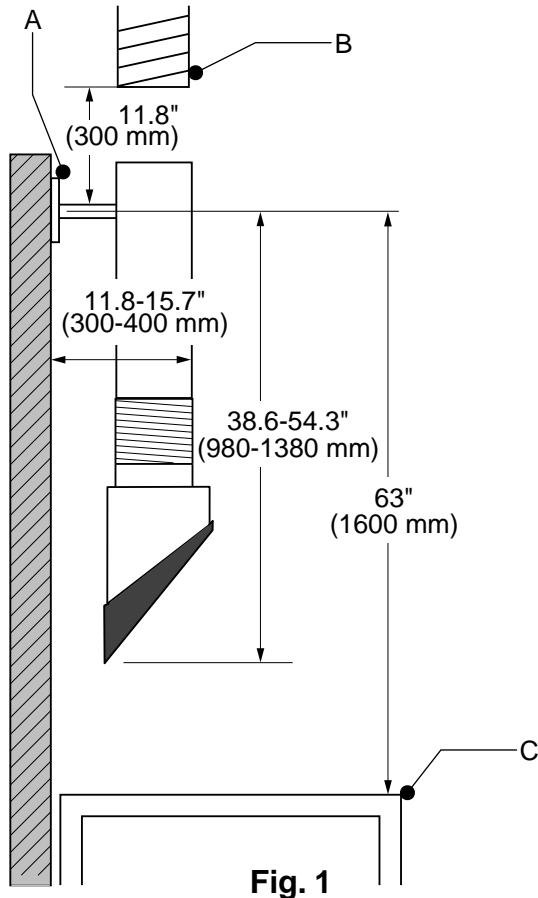

Fig. 1

Disconnect the mounting bracket from the arm before mounting, by removing the 1.75" bolt (Fig. 3C), and sliding the post out of the friction block. Mount the telescopic arm mounting bracket to the wall. Standard mounting height is 5 ft. (130 mm) from the work table to the center of the bracket. Refer to Figure 2 for drilling dimensions.

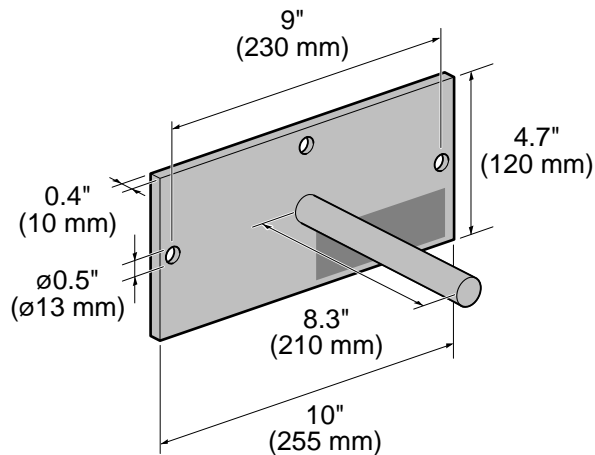

Fig. 2

Remount the arm to the mounting bracket by sliding the friction block over the post of the bracket (Fig. 3A) and replacing the 1.75" bolt and nut (Fig. 3C).

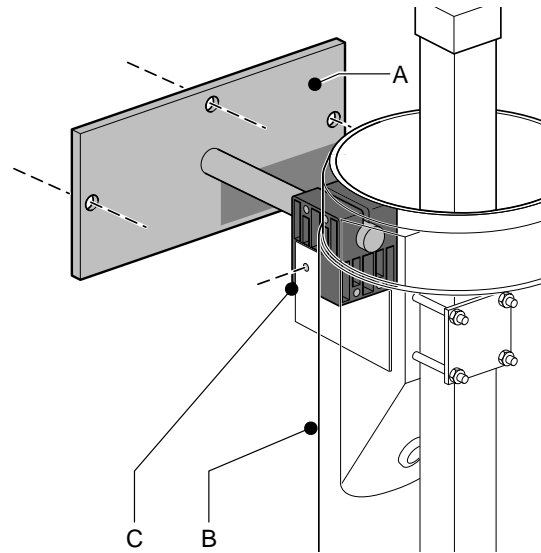

Fig. 3

ADJUSTING THE FRICTION OF THE TELESCOPIC ARM

The amount of friction resistance should be set such that the arm is comfortable to move (always test both up and down movements), yet hold its position against gravity once positioned.

To adjust the friction resistance of the hood movement, fold back the rubber band onto the hood, and push up the flexible hose, exposing the connection blocks. Use an 8mm wrench to adjust the bolt/nut pairs as shown in Fig. 4.

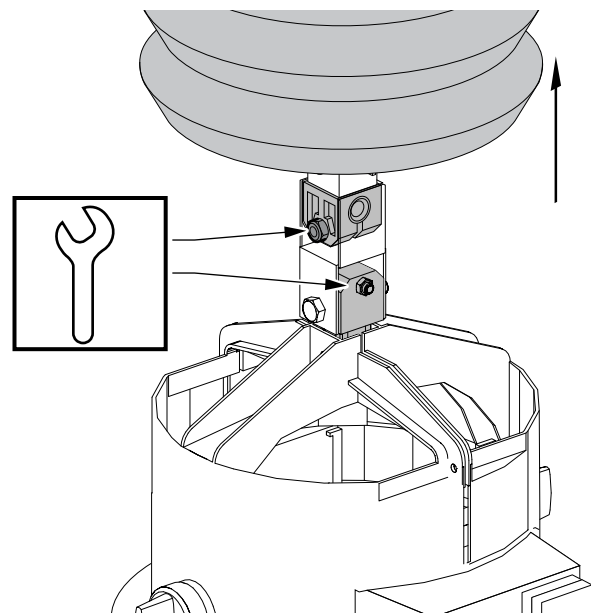

Fig. 4

LTA 2.0 TELESCOPIC EXTRACTION ARM



ADJUSTING THE FRICTION OF THE TELESCOPIC ARM

(continued)

The amount of friction resistance should be set such that the arm is comfortable to move (always test both up and down movements), yet hold its position against gravity once positioned.

To adjust the friction setting for side to side movement of the arm, use the top two bolt/nut sets on the rotating hinge (Fig. 5A).

To adjust the friction setting for front to back movement, adjust the front bolt/nut set (Fig. 5E) on the rotating hinge.

To adjust the friction setting for the telescopic motion of the arm, remove the black cap (Fig. 5B) and turn the set screw (Fig. 5D) counterclockwise to increase friction and clockwise to decrease it.

Fig. 5

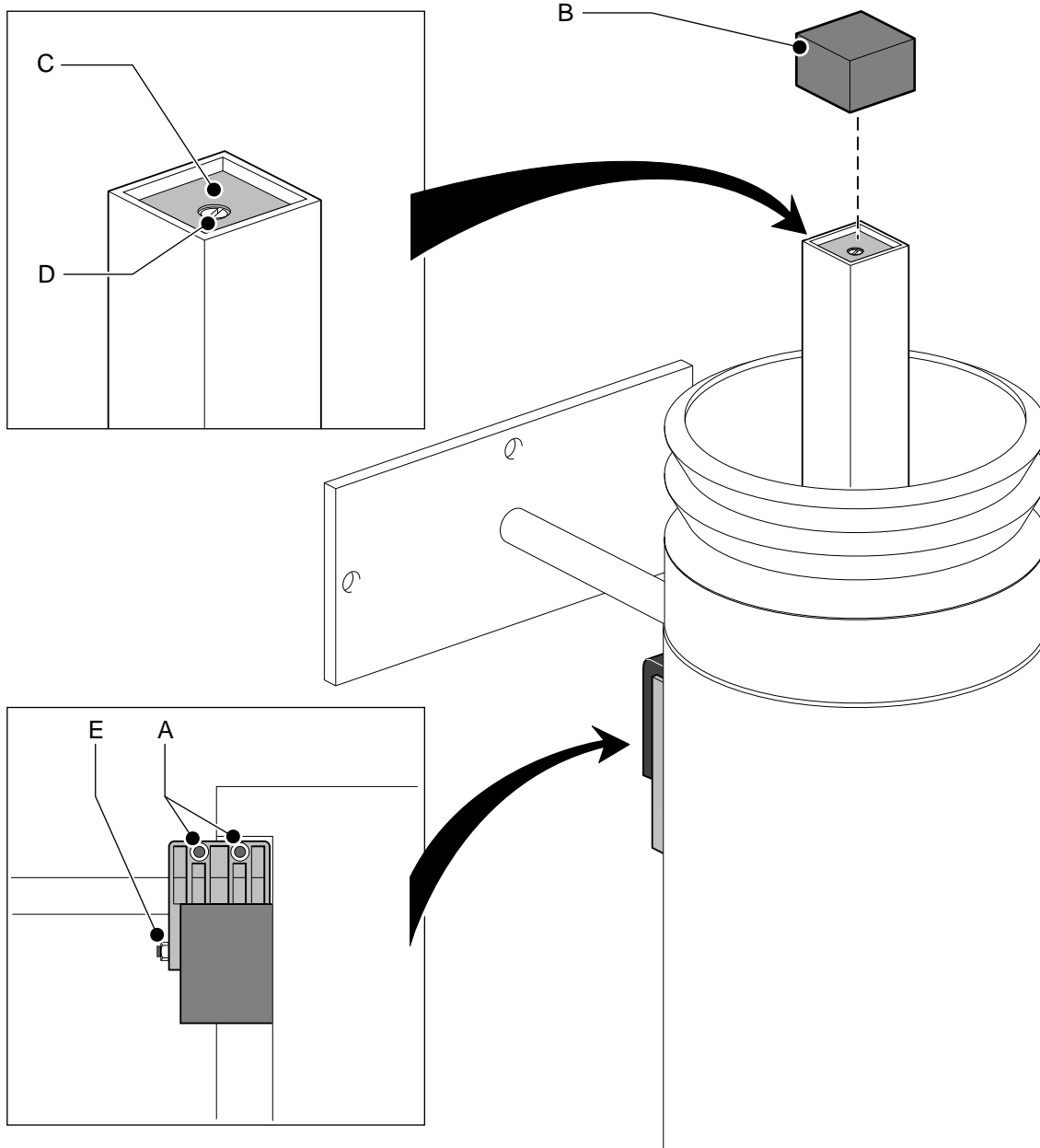

LTA 2.0 TELESCOPIC EXTRACTION ARM

LINCOLN[®]
ELECTRIC

Read and understand this entire section before operating your LTA 2.0 Telescopic Extraction Arm.

SAFETY INSTRUCTIONS

Do not attempt to use this equipment until you have thoroughly read all operating and maintenance manuals supplied with your equipment and any related welding machine it will be used with. They include important safety precautions, operating and maintenance instructions and parts lists.

WARNING



ELECTRIC SHOCK can kill.

- Do not touch electrically live parts such as output terminals or internal wiring.
- Insulate yourself from the work and ground.
- Always wear dry insulating gloves.

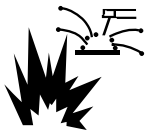

WELDING SPARKS can cause fire or explosion.

- Keep flammable material away.
- Do not weld upon containers which have held combustibles.



ARC RAYS can burn.

- Wear eye, ear and body protection.



FUMES AND GASES can be dangerous.

- Although the removal of the particulate matter from welding smoke may reduce the ventilation requirement, concentrations of the clear exhausted fumes and gases may still be hazardous to health. Avoid breathing concentrations of these fumes and gases. Use adequate ventilation when welding. See ANSI Z49.1, "Safety in Welding and Cutting", published by the American Welding Society.

Only qualified personnel should operate this equipment.

ADDITIONAL SAFETY PRECAUTIONS

Always operate the fan with the arm installed and all covers in place as these provide maximum protection from moving parts and insure proper vacuum operation and cooling air flow.

OPERATING INSTRUCTIONS

Turn on the extraction fan (if using an SF2400 Fan, refer to the Operating Instructions in the SF2400 Stationary Fan manual for details).

Position hood within 10-15 inches (250-400mm) of the arc. Use the airflow throttle valve on the base of the hood to adjust the airflow to an appropriate level, if desired.

If using a Lamp Kit:

The switch on the hood with a lamp symbol operates the work lamp in the hood.

If using an Auto Start/Stop Arc Sensor:

The arc sensor will automatically switch the fan on when it senses an arc. Standard run-out time is approximately 20 sec. The work lamp operates independently of this sensor.

ROUTINE MAINTENANCE

Every 3 months:

- Check the integrity of the outside of the extraction arm and clean it with a non-aggressive detergent.
- Check the friction setting of the rotating hinge and telescopic movement of the arm (Refer to Fig. 6); adjust if necessary. Refer to “Adjustment of Friction” portion of Installation section of this manual.

Every 12 months:

- Check the flexible hoses and rubber bands for cracks or damage; replace if necessary.
- Check the inside of the extraction arm and clean it thoroughly.
- Check the friction setting of the hood hinge. Adjust if necessary (Refer to Fig. 6). Refer to “Adjustment of Friction” portion of Installation section of this manual.
- Check the operation of the airflow throttle valve.

Fig. 6

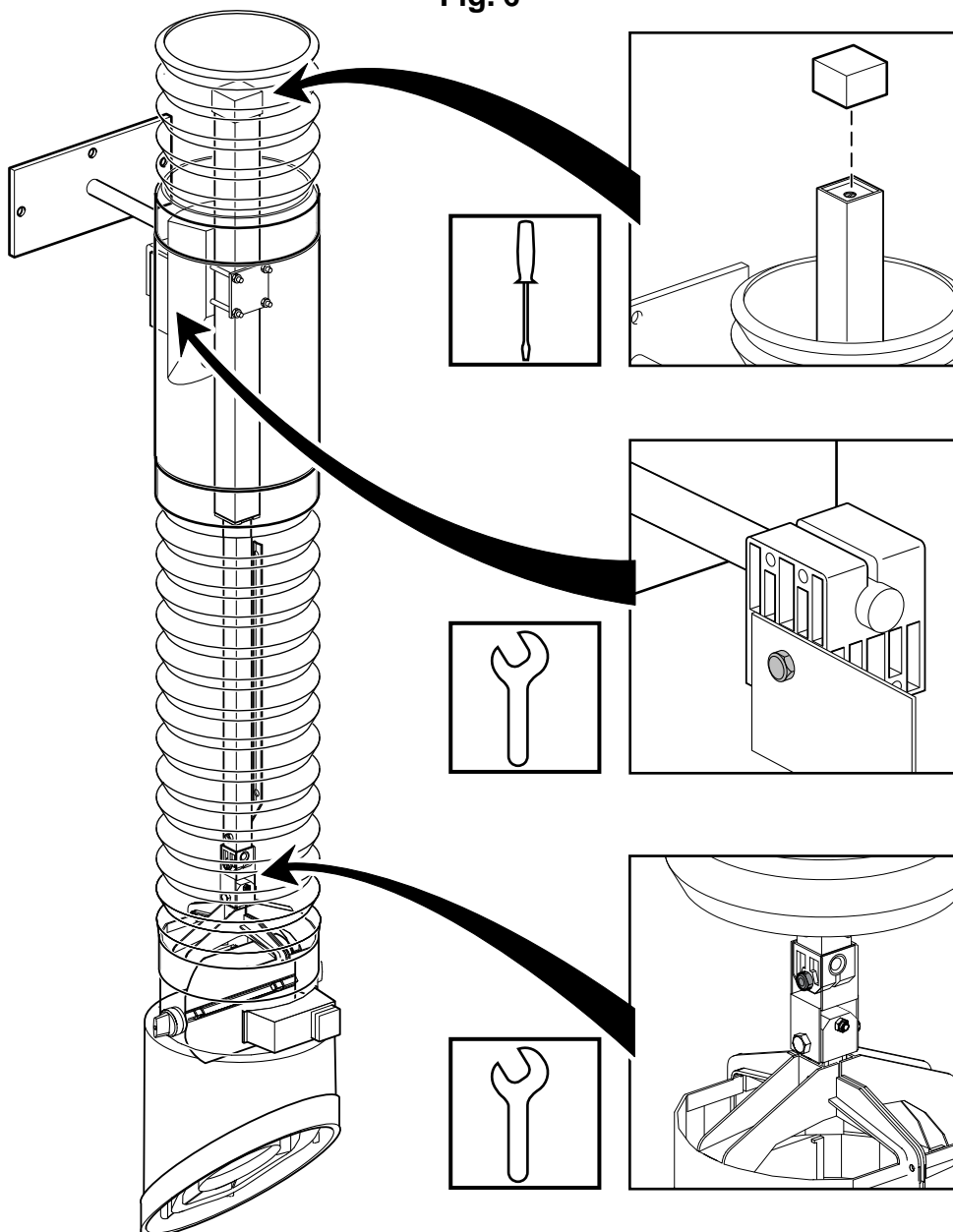

LTA 2.0 TELESCOPIC EXTRACTION ARM

Observe all Safety Guidelines detailed throughout this manual

SYMPTOM	PROBLEM	SOLUTION
Extraction arm creaks or squeaks.	Insufficient lubrication.	Lubricate hinge points as described in the Maintenance Section.
Poor suction.	Leakage. Outlet (of fan) blocked. Air path in arm blocked. Filter blocked (if used). Spark arrester blocked (if used). Blower fan blocked. Fan seal damaged. Throttle valve closed.	Check hose connections and integrity Remove obstructions from outlet. Remove obstructions from arm. Check maintenance indicator and replace filter if necessary. Clean the spark arrester. Clean excess fume or spatter from fan. Check or replace sealing material of fan. Open the airflow throttle valve.
Arm does not position correctly.	Friction settings out of adjustment.	Adjust friction settings as necessary: (Refer to "Adjustment of Friction" portion of Installation section of this manual) Rotating hinge (side-side movement, and front-back movement of the arm) Telescopic set screw (telescopic movement) Hood hinge (hood movement)
For troubleshooting Fan or Filter problems, refer to the corresponding manual.		

 **CAUTION**

If for any reason you do not understand the test procedures or are unable to perform the tests/repairs safely, contact your **Local Lincoln Authorized Field Service Facility** for technical troubleshooting assistance before you proceed.

LTA 2.0 TELESCOPIC EXTRACTION ARM



PARTS LIST FOR

Fume Extraction Arms

This parts list is provided as an informative guide only.

This information was accurate at the time of printing. However, since these pages are regularly updated in Lincoln Electric's official Parts Book (BK-34), always check with your Lincoln parts supplier for the latest parts information.

FUME EXTRACTION ARMS



NOTES

FUME EXTRACTION ARMS



LFA 3.1 and 4.1 Fume Extraction Arm Assembly

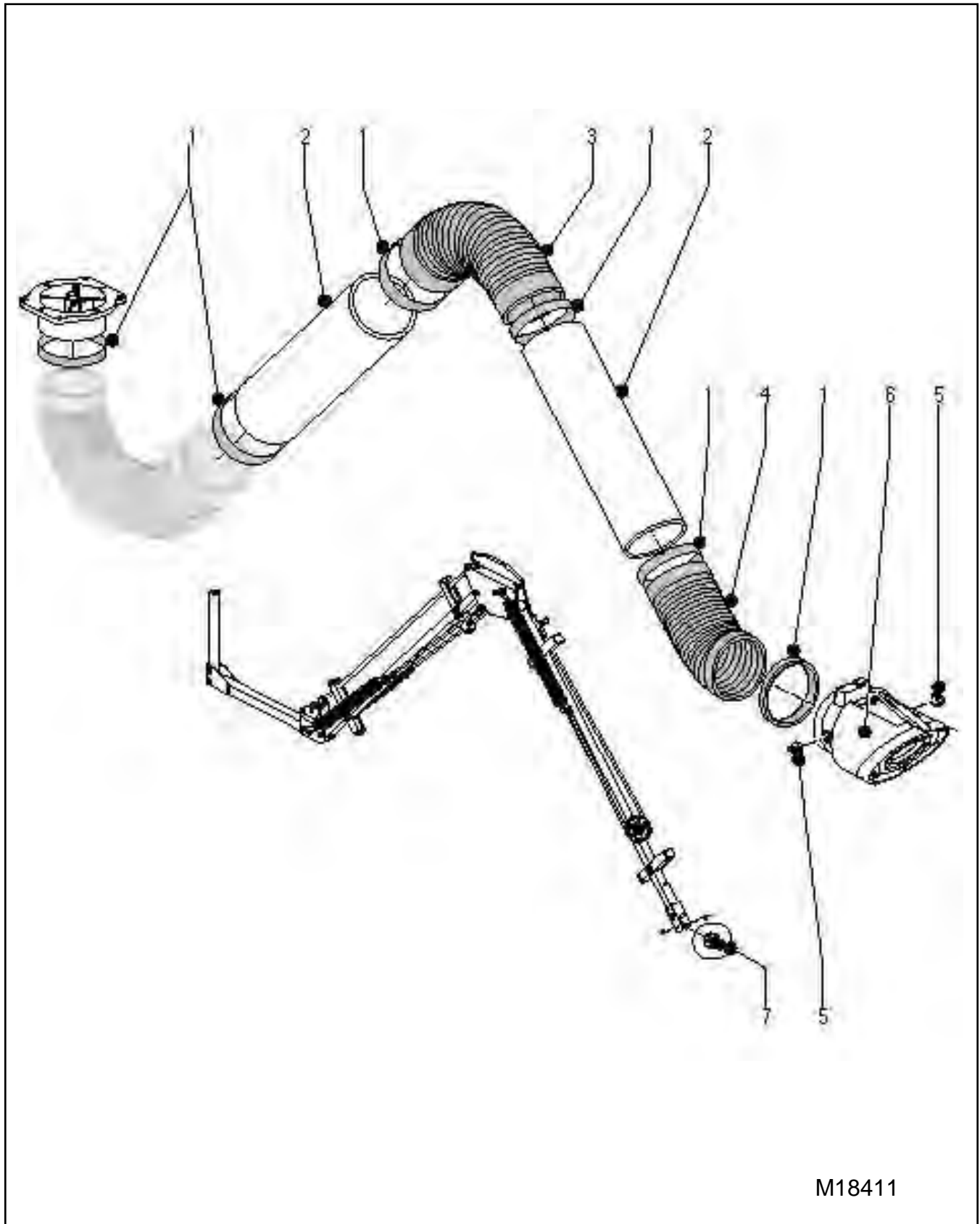

M18411

Indicates a change this printing.

Use only the parts marked "x" in the column under the heading number called for in the model index page.

Recommended Spare Parts are Highlighted in Bold

ITEM	DESCRIPTION	PART NO.	QTY.	1	2	3	4	5	6	7	8	9
1	Rubber Seal, 8.0"	S23282-1	6	X	X							
2	Arm Section, LFA 3.1, 2.5 ft.	S23282-2	2	X	•							
2	Arm Section, LFA 4.1, 4.0 ft.	S23282-3	2	•	X							
4	Replacement Hose Section, 4.0 ft.	S23282-12	2	X	X							
5	Knob, Airflow Throttle Valve	S23282-4	2	X	X							
6	Hood Assembly	S23282-5	1	X	X							
7	Plastic Friction Plug	S23282-6	2	X	X							

LTA 2.0 Telescopic Fume Extraction Arm Assembly

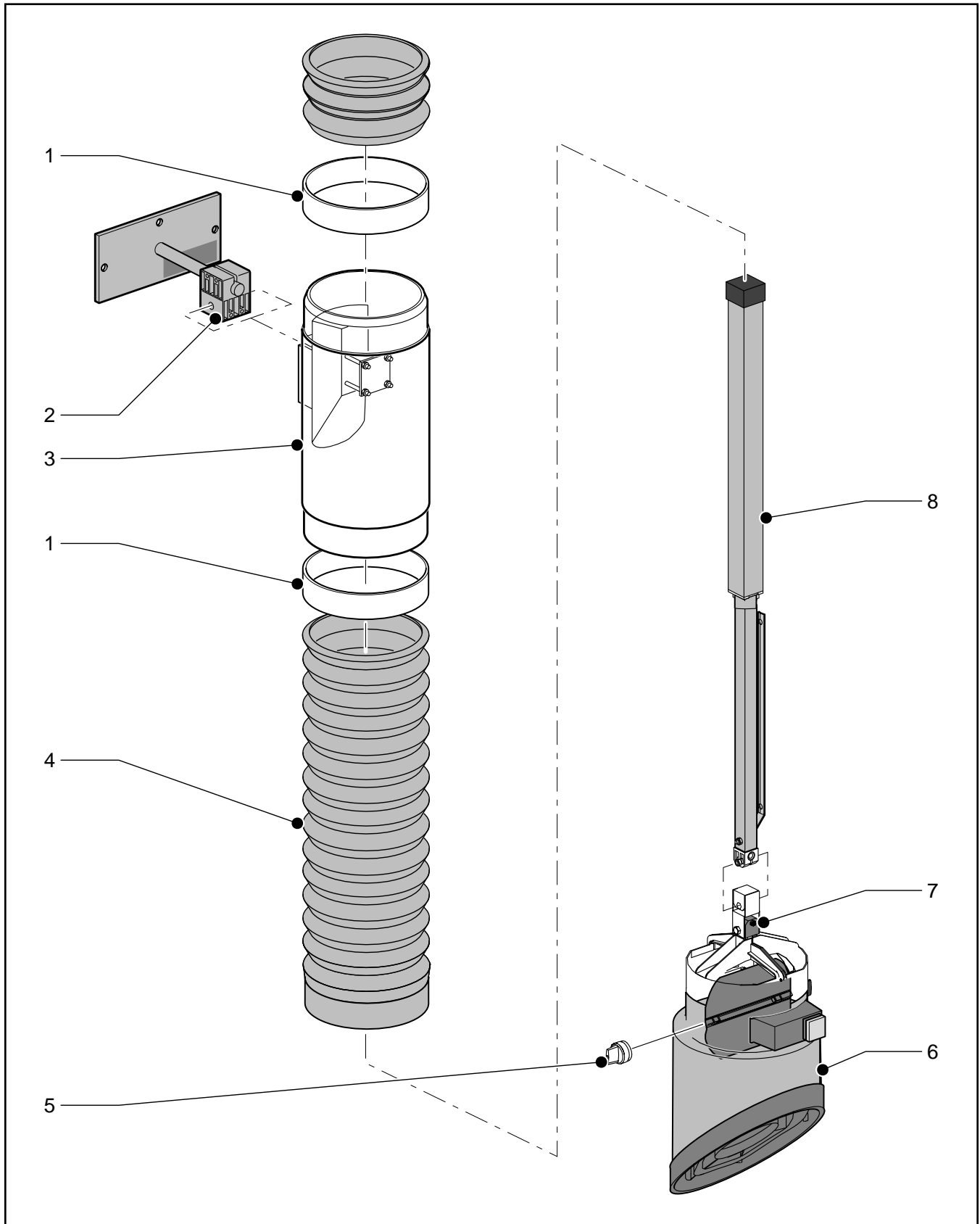

Indicates a change this printing.

Use only the parts marked "x" in the column under the heading number called for in the model index page.

Recommended Spare Parts are Highlighted in Bold

ITEM	DESCRIPTION	PART NO.	QTY.	1	2	3	4	5	6	7	8	9
1	Elastic Band, 8"	S23282-1	4	X								
2	Rotating Hinge, LTA	S23282-7	1	X								
3	Arm Section, LTA	S23282-8	1	X								
4	Replacement Hose Section, 4 ft.	S23282-12	2	X								
5	Airflow Valve Control Knob	S23282-4	1	X								
6	Hood Assembly	S23282-5	1	X								
7	Plastic Friction Plug	S23282-6	1	X								
8	Telescopic Guide	S23282-9	1	X								

NOTES

NOTES

NOTES

WARNING	<ul style="list-style-type: none"> ● Do not touch electrically live parts or electrode with skin or wet clothing. ● Insulate yourself from work and ground. 	<ul style="list-style-type: none"> ● Keep flammable materials away. 	<ul style="list-style-type: none"> ● Wear eye, ear and body protection.
Spanish AVISO DE PRECAUCION	<ul style="list-style-type: none"> ● No toque las partes o los electrodos bajo carga con la piel o ropa mojada. ● Aíslese del trabajo y de la tierra. 	<ul style="list-style-type: none"> ● Mantenga el material combustible fuera del área de trabajo. 	<ul style="list-style-type: none"> ● Protéjase los ojos, los oídos y el cuerpo.
French ATTENTION	<ul style="list-style-type: none"> ● Ne laissez ni la peau ni des vêtements mouillés entrer en contact avec des pièces sous tension. ● Isolez-vous du travail et de la terre. 	<ul style="list-style-type: none"> ● Gardez à l'écart de tout matériel inflammable. 	<ul style="list-style-type: none"> ● Protégez vos yeux, vos oreilles et votre corps.
German WARNUNG	<ul style="list-style-type: none"> ● Berühren Sie keine stromführenden Teile oder Elektroden mit Ihrem Körper oder feuchter Kleidung! ● Isolieren Sie sich von den Elektroden und dem Erdboden! 	<ul style="list-style-type: none"> ● Entfernen Sie brennbares Material! 	<ul style="list-style-type: none"> ● Tragen Sie Augen-, Ohren- und Körperschutz!
Portuguese ATENÇÃO	<ul style="list-style-type: none"> ● Não toque partes elétricas e electrodos com a pele ou roupa molhada. ● Isole-se da peça e terra. 	<ul style="list-style-type: none"> ● Mantenha inflamáveis bem guardados. 	<ul style="list-style-type: none"> ● Use proteção para a vista, ouvido e corpo.
Japanese 注意事項	<ul style="list-style-type: none"> ● 通電中の電気部品、又は溶材にヒフやぬれた布で触れないこと。 ● 施工物やアースから身体が絶縁されている様にして下さい。 	<ul style="list-style-type: none"> ● 燃えやすいものの側での溶接作業は絶対にしてはなりません。 	<ul style="list-style-type: none"> ● 目、耳及び身体に保護具をして下さい。
Chinese 警告	<ul style="list-style-type: none"> ● 皮膚或濕衣物切勿接觸帶電部件及鎢條。 ● 使你自已與地面和工件絕緣。 	<ul style="list-style-type: none"> ● 把一切易燃物品移離工作場所。 	<ul style="list-style-type: none"> ● 佩戴眼、耳及身體勞動保護用具。
Korean 위험	<ul style="list-style-type: none"> ● 전도체나 용접봉을 젖은 형갑 또는 피부로 절대 접촉치 마십시오. ● 모재와 접지를 접촉치 마십시오. 	<ul style="list-style-type: none"> ● 인화성 물질을 접근시키지 마십시오. 	<ul style="list-style-type: none"> ● 눈, 귀와 몸에 보호장구를 착용하십시오.
Arabic تحذير	<ul style="list-style-type: none"> ● لا تلمس الاجزاء التي يسري فيها التيار الكهربائي أو الألكترود بجسدك أو بالملابس المبللة بالماء. ● ضع عازلا على جسمك خلال العمل. 	<ul style="list-style-type: none"> ● ضع المواد القابلة للاشتعال في مكان بعيد. 	<ul style="list-style-type: none"> ● ضع أدوات وملابس واقية على عينيك وأذنيك وجسمك.

READ AND UNDERSTAND THE MANUFACTURER'S INSTRUCTION FOR THIS EQUIPMENT AND THE CONSUMABLES TO BE USED AND FOLLOW YOUR EMPLOYER'S SAFETY PRACTICES.

SE RECOMIENDA LEER Y ENTENDER LAS INSTRUCCIONES DEL FABRICANTE PARA EL USO DE ESTE EQUIPO Y LOS CONSUMIBLES QUE VA A UTILIZAR, SIGA LAS MEDIDAS DE SEGURIDAD DE SU SUPERVISOR.

LISEZ ET COMPRENEZ LES INSTRUCTIONS DU FABRICANT EN CE QUI REGARDE CET EQUIPMENT ET LES PRODUITS A ETRE EMPLOYES ET SUIVEZ LES PROCEDURES DE SECURITE DE VOTRE EMPLOYEUR.

LESEN SIE UND BEFOLGEN SIE DIE BETRIEBSANLEITUNG DER ANLAGE UND DEN ELEKTRODENEINSATZ DES HERSTELLERS. DIE UNFALLVERHÜTUNGSVORSCHRIFTEN DES ARBEITGEBERS SIND EBENFALLS ZU BEACHTEN.

			
<ul style="list-style-type: none"> ● Keep your head out of fumes. ● Use ventilation or exhaust to remove fumes from breathing zone. 	<ul style="list-style-type: none"> ● Turn power off before servicing. 	<ul style="list-style-type: none"> ● Do not operate with panel open or guards off. 	WARNING
<ul style="list-style-type: none"> ● Los humos fuera de la zona de respiración. ● Mantenga la cabeza fuera de los humos. Utilice ventilación o aspiración para gases. 	<ul style="list-style-type: none"> ● Desconectar el cable de alimentación de poder de la máquina antes de iniciar cualquier servicio. 	<ul style="list-style-type: none"> ● No operar con panel abierto o guardas quitadas. 	Spanish AVISO DE PRECAUCION
<ul style="list-style-type: none"> ● Gardez la tête à l'écart des fumées. ● Utilisez un ventilateur ou un aspirateur pour ôter les fumées des zones de travail. 	<ul style="list-style-type: none"> ● Débranchez le courant avant l'entretien. 	<ul style="list-style-type: none"> ● N'opérez pas avec les panneaux ouverts ou avec les dispositifs de protection enlevés. 	French ATTENTION
<ul style="list-style-type: none"> ● Vermeiden Sie das Einatmen von Schweißrauch! ● Sorgen Sie für gute Be- und Entlüftung des Arbeitsplatzes! 	<ul style="list-style-type: none"> ● Strom vor Wartungsarbeiten abschalten! (Netzstrom völlig öffnen; Maschine anhalten!) 	<ul style="list-style-type: none"> ● Anlage nie ohne Schutzgehäuse oder Innenschutzverkleidung in Betrieb setzen! 	German WARNUNG
<ul style="list-style-type: none"> ● Mantenha seu rosto da fumaça. ● Use ventilação e exaustão para remover fumo da zona respiratória. 	<ul style="list-style-type: none"> ● Não opere com as tampas removidas. ● Desligue a corrente antes de fazer serviço. ● Não toque as partes elétricas nuas. 	<ul style="list-style-type: none"> ● Mantenha-se afastado das partes moventes. ● Não opere com os painéis abertos ou guardas removidas. 	Portuguese ATENÇÃO
<ul style="list-style-type: none"> ● ヒュームから頭を離すようにして下さい。 ● 換気や排煙に十分留意して下さい。 	<ul style="list-style-type: none"> ● メンテナンス・サービスに取りかかる際には、まず電源スイッチを必ず切ってください。 	<ul style="list-style-type: none"> ● パネルやカバーを取り外したまま機械操作をしないで下さい。 	Japanese 注意事項
<ul style="list-style-type: none"> ● 頭部遠離煙霧。 ● 在呼吸區使用通風或排風器除煙。 	<ul style="list-style-type: none"> ● 維修前切斷電源。 	<ul style="list-style-type: none"> ● 儀表板打開或沒有安全罩時不準作業。 	Chinese 警告
<ul style="list-style-type: none"> ● 얼굴로부터 용접가스를 멀리하십시오. ● 호흡지역으로부터 용접가스를 제거하기 위해 가스제거기나 통풍기를 사용하십시오. 	<ul style="list-style-type: none"> ● 보수전에 전원을 차단하십시오. 	<ul style="list-style-type: none"> ● 판넬이 열린 상태로 작동치 마십시오. 	Korean 위험
<ul style="list-style-type: none"> ● ابعد رأسك بعيداً عن الدخان. ● استعمل التهوية أو جهاز ضغط الدخان للخارج لكي تبعد الدخان عن المنطقة التي تتنفس فيها. 	<ul style="list-style-type: none"> ● أقطع التيار الكهربائي قبل القيام بأية صيانة. 	<ul style="list-style-type: none"> ● لا تشغيل هذا الجهاز اذا كانت الاغطية الحديدية الواقية ليست عليه. 	Arabic تحذير

LEIA E COMPREENDA AS INSTRUÇÕES DO FABRICANTE PARA ESTE EQUIPAMENTO E AS PARTES DE USO, E SIGA AS PRÁTICAS DE SEGURANÇA DO EMPREGADOR.

使う機械や溶材のメーカーの指示書をよく読み、まず理解して下さい。そして貴社の安全規定に従って下さい。

請詳細閱讀並理解製造廠提供的說明以及應該使用的銀焊材料，並請遵守貴方的有閣勞動保護規定。

이 제품에 동봉된 작업지침서를 숙지하시고 귀사의 작업자 안전수칙을 준수하시기 바랍니다.

اقرأ بتمعن وافهم تعليمات المصنع المنتج لهذه المعدات والمواد قبل استعمالها واتبع تعليمات الوقاية لصاحب العمل.



• World's Leader in Welding and Cutting Products •

• Sales and Service through Subsidiaries and Distributors Worldwide •

Cleveland, Ohio 44117-1199 U.S.A. TEL: 216.481.8100 FAX: 216.486.1751 WEB SITE: www.lincolnelectric.com